

 HiRef



CATALOGUE  
**DATA CENTER**

 HiRef

# Perimeter-mounted units

	SYSTEM TYPE	VERSIONS	REFRIGERANT	RANGE	
	<b>CHILLED WATER PERIMETER MOUNTED UNITS FOR DATA CENTERS</b>				
<b>TRF CW</b>	CHILLED WATER			<b>33-257</b> (kW)	PAGE <b>14</b>
	<b>CHILLED WATER PERIMETER MOUNTED AIR CONDITIONING UNITS FOR DATA CENTER WITH UNDERFLOOR FANS - SLIM EDITION</b>				
<b>TRF CS</b>	CHILLED WATER			<b>58-242</b> (kW)	PAGE <b>16</b>
	<b>CHILLED WATER PERIMETER MOUNTED UNITS FOR DATA CENTERS WITH UNDERFLOOR FANS</b>				
<b>TRF CF</b>	CHILLED WATER			<b>78-329</b> (kW)	PAGE <b>18</b>
	<b>AIR CONDENSED PERIMETER MOUNTED UNITS FOR DATA CENTERS</b>				
<b>TRF DX A</b>	AIR-AIR		 	<b>24-160</b> (kW)	PAGE <b>20</b>
	<b>WATER CONDENSED PERIMETER MOUNTED UNITS FOR DATA CENTERS</b>				
<b>TRF DX W/Z</b>	AIR-WATER		 	Mod. W <b>24-165</b> (kW) Mod. Z <b>28-185</b> (kW)	PAGE <b>22</b>
	<b>PERIMETER MOUNTED UNITS FOR DATA CENTERS WITH INDIRECT FREE-COOLING</b>				
<b>TRF DX F</b>	AIR-WATER		 	<b>23-150</b> (kW)	PAGE <b>24</b>
	<b>DUAL COOLING PERIMETER MOUNTED UNITS FOR DATA CENTERS</b>				
<b>TRF DX D/K/Q</b>	Mod. D AIR-AIR Mod. Q/K AIR-WATER		 	Mod. D <b>23-149</b> (kW) Mod. K <b>23-152</b> (kW) Mod. Q <b>27-170</b> (kW)	PAGE <b>26</b>
	<b>AIR CONDENSED PERIMETER MOUNTED UNITS FOR DATA CENTERS WITH MODULATING COMPRESSORS</b>				
<b>NRG A</b>	AIR-AIR		 	<b>9-159</b> (kW)	PAGE <b>30</b>
	<b>WATER CONDENSED PERIMETER MOUNTED UNITS FOR DATA CENTERS WITH MODULATING COMPRESSORS</b>				
<b>NRG W/Z</b>	AIR-WATER		 	Mod. W <b>9-166</b> (kW) Mod. Z <b>10-182</b> (kW)	PAGE <b>32</b>

Technical data are subject to change without notice. Do not use these data in the design stage.

# Perimeter-mounted units

	SYSTEM TYPE	VERSIONS	REFRIGERANT	RANGE	
	<b>PERIMETER MOUNTED UNITS FOR DATA CENTERS WITH MODULATING COMPRESSORS WITH INDIRECT FREE-COOLING</b>				
<b>NRG F</b>	ARIA/ACQUA		 	11-155 (kW)	PAGE <b>34</b>
	<b>DUAL COOLING PERIMETER MOUNTED UNITS FOR DATA CENTERS WITH MODULATING COMPRESSORS</b>				
<b>NRG D/K/Q</b>	Mod. D AIR-AIR Mod. Q/K AIR-WATER			Mod. D 12-153 (kW) Mod. K 11-158 (kW) Mod. Q 13-174 (kW)	PAGE <b>36</b>
	<b>CHILLED WATER PERIMETER MOUNTED UNITS FOR DATA CENTERS</b>				
<b>JREF CW</b> Radial	CHILLED WATER			15-33 (kW)	PAGE <b>40</b>
	<b>AIR CONDENSED PERIMETER MOUNTED UNITS FOR DATA CENTERS</b>				
<b>JREF DX A</b> Radial	AIR-AIR		 	7-25 (kW)	PAGE <b>42</b>
	<b>WATER CONDENSED PERIMETER MOUNTED UNITS FOR DATA CENTERS</b>				
<b>JREF DX W/Z</b> Radial	AIR-WATER		 	Mod. W 7-24 (kW) Mod. Z 7-27 (kW)	PAGE <b>44</b>
	<b>CHILLED WATER PERIMETER MOUNTED UNITS FOR DATA CENTERS</b>				
<b>JREF CW</b> Centrifugal	CHILLED WATER			7-24 (kW)	PAGE <b>46</b>
	<b>AIR CONDENSED PERIMETER MOUNTED UNITS FOR DATA CENTERS</b>				
<b>JREF DX A</b> Centrifugal	AIR-AIR			7-24 (kW)	PAGE <b>48</b>
	<b>WATER CONDENSED PERIMETER MOUNTED UNITS FOR DATA CENTERS</b>				
<b>JREF DX W/Z</b> Centrifugal	AIR-WATER			Mod. W 7-24 (kW) Mod. Z 7-28 (kW)	PAGE <b>50</b>
	<b>FANWALL AIR CONDITIONERS CHILLED WATER OR DIRECT EXPANSION VERSIONS FOR HIGH DENSITY HYPERSCALE DATA CENTER</b>				
<b>FanWall HBCV</b>	CHILLED WATER			45-461 (kW)	PAGE <b>52</b>

Technical data are subject to change without notice. Do not use these data in the design stage.

# Perimeter-mounted units



CHILLED WATER UNITS FOR MEDIUM/SMALL SERVER ROOMS

**HTI CW**

CHILLED WATER



REFRIGERANT

RANGE

8-45 (kW)

PAGE 54

# Evaporative air conditioner air-to-air



AIR/AIR SYSTEMS FOR DATA CENTERS WITH ADIABATIC SYSTEM

**DataBatic**

AIR-AIR



10-330 (kW)

PAGE 58

# High Density Cooling



DIRECT EXPANSION AIR CONDITIONERS FOR HIGH DENSITY RACKS WITH MODULATING COMPRESSORS

**NRCD/NRCV**

AIR-AIR



Mod. NRCD 12-50 (kW)  
Mod. NRCV 13-37 (kW)

PAGE 62



CHILLED WATER AIR CONDITIONING UNITS FOR HIGH POWER DENSITY RACKS

**HRCC**

CHILLED WATER



20-57 (kW)

PAGE 64



MINI RACK COOLER FOR HIGH DENSITY SYSTEM

**MRAC CW/DX**

CHILLED WATER  
AIR-AIR



Mod. CW 3-5 (kW)  
Mod. DX 4-8 (kW)

PAGE 66



REAR DOOR COOLING FOR HIGH DENSITY HYPERSCALE DATA CENTER

**RDC**

AIR-WATER



25-61 (kW)

PAGE 68



Cooling Only



Heating Only



Reversible Heat Pump



Free-Cooling



Motoevaporating



Polyvalent for 2-pipe system



Polyvalent for 4-pipe system

# Liquid cooling



SYSTEM TYPE	VERSIONS	REFRIGERANT	RANGE
<b>COOLANT DISTRIBUTION UNIT FOR HIGH DENSITY HYPERSCALE DATA CENTER</b>			
<b>CDU</b>	ACQUA/ACQUA		PAGE <b>80</b>

# Dry Cooler and remote condensers



<b>MODULAR DRY COOLER</b>			
<b>HDC</b>	AIR-WATER		372-1551 (kW) PAGE <b>84</b>



<b>REMOTE CONDENSERS AND DRY COOLER</b>			
<b>REMOTE CONDENSERS</b>	AIR-AIR AIR-WATER		PAGE <b>86</b>

# Liquid chillers



<b>CHILLERS WITH REMOTE CONDENSER WITH SCROLL COMPRESSORS</b>			
<b>TSE</b>	AIR-WATER	ME	43-433 (kW) PAGE <b>90</b>



<b>AIR CONDENSED CHILLERS WITH INVERTER DRIVEN SCREW COMPRESSORS</b>			
<b>TVD</b>	AIR-WATER		512-1586 (kW) PAGE <b>92</b>



<b>AIR CONDENSED CHILLERS WITH OIL-FREE CENTRIFUGAL COMPRESSORS</b>			
<b>TTX</b>	AIR-WATER		540-2120 (kW) PAGE <b>94</b>

















































<b>WATER-CONDENSED CHILLERS WITH OIL-FREE CENTRIFUGAL COMPRESSORS</b>			
<b>XTW</b>	WATER-WATER		500-2400 (kW) PAGE <b>96</b>



<b>WATER CONDENSED CHILLERS AND HEAT PUMPS WITH SCREW COMPRESSORS</b>			
<b>XVA</b>	WATER-WATER		445-1494 (kW) PAGE <b>98</b>







Technical data are subject to change without notice. Do not use these data in the design stage.

# Liquid chillers and reversible heat pumps



	SYSTEM TYPE	VERSIONS	REFRIGERANT	RANGE	PAGE	
	<b>CDA</b>	<b>AIR-COOLED CHILLERS AND HEAT PUMPS WITH NATURAL REFRIGERANT R744 (CO<sub>2</sub>) AND MODULATING COMPRESSORS</b>				
	AIR-WATER	  		75-706 (kW)	102	
	<b>TSS</b>	<b>CLASS A CHILLERS AND HEAT PUMPS AIR CONDENSED WITH SCROLL COMPRESSORS</b>				
	AIR-WATER	 	 	120-265 (kW)	104	
	<b>TAS</b>	<b>AIR CONDENSED CHILLERS AND HEAT PUMPS WITH SCROLL COMPRESSORS</b>				
	AIR-WATER	  	 	60-261 (kW)	106	
	<b>MHA</b>	<b>AIR CONDENSED CHILLERS AND HEAT PUMPS WITH SCROLL BLDC INVERTER COMPRESSORS</b>				
	AIR-WATER	  	 	30-288 (kW)	108	
	<b>TPS</b>	<b>AIR CONDENSED CHILLERS AND HEAT PUMPS WITH SCROLL COMPRESSORS</b>				
	AIR-WATER	  	 	43-445 (kW)	110	
	<b>TSL</b>	<b>CLASS A CHILLERS AND HEAT PUMPS AIR CONDENSED WITH SCROLL COMPRESSORS</b>				
	AIR-WATER	  	 	277-1004 (kW)	112	
	<b>TAL</b>	<b>CLASS A CHILLERS AND HEAT PUMPS AIR CONDENSED WITH SCROLL COMPRESSORS</b>				
	AIR-WATER	  	 	283-1166 (kW)	114	
	<b>TPL</b>	<b>AIR CONDENSED CHILLERS AND HEAT PUMPS WITH SCROLL COMPRESSORS</b>				
	AIR-WATER	  	 	365-1199 (kW)	116	

 Cooling Only	 Heating Only	 Reversible Heat Pump	 Free-Cooling	 Motoevaporating	 Polyvalent for 2-pipe system	 Polyvalent for 4-pipe system
--	--	--	--	---	--	--

# High temperature heat pumps

	SYSTEM TYPE	VERSIONS	REFRIGERANT	RANGE	PAGE
<b>HIGH TEMPERATURE HEAT PUMPS WITH TWO-STAGE COMPRESSORS</b>					
	<b>KVV</b> WATER-WATER			<b>324-2208</b> (kW)	<b>120</b>
<b>HEATING-ONLY WATER CONDENSED HEAT PUMPS WITH INVERTER DRIVEN SCREW COMPRESSORS</b>					
	<b>XVA K</b> WATER-WATER			<b>408-1679</b> (kW)	<b>122</b>

# Hydraulic modules

	SYSTEM TYPE	VERSIONS	PAGE
<b>POLYMORPH HYDRONIC MODULES FOR WATER/WATER CHILLERS SYSTEMS</b>			
	<b>PLM</b> WATER-WATER		<b>126</b>

# Supervision

	ADVANCED TECHNOLOGY AND FLEXIBILITY TO MANAGE AIR CONDITIONING AND PROCESS COOLING	PAGE
	<b>HiNode</b>	<b>130</b>

Technical data are subject to change without notice. Do not use these data in the design stage.



CATALOGUE  
DATA CENTER

---

# Platform TRF Evolution

## Inspired by the best of TREF Revolutionary design

**Efficiency, flexibility, reduced footprint, optimization of internal layout.**

**TRF Evolution** is the new family of HiRef **perimeter-mounted cabinets** designed for data centre air conditioning. It brings together in a single and revolutionary family the many product ranges already on offer, from chilled-water to direct expansion units. Units of the TRF Evolution platform have everything needed to provide **the most efficient** Data Center cooling solution, ensuring **reliability, precise control** of thermo-hygrometric conditions and the **flexibility to adapt** to different working conditions. The depth has been increased to 890 mm and 960 mm, with a finned-coil exchanger 30%

larger in the NRG and TRF DX versions and 16% larger in the TRF CW, compared to the units of previous generations. There is a rise in specific capacity (kW/Sq.m) and efficiency, thanks to a next-generation fan that **increases performance by 15%**. Each HiRef unit is also customizable in the co-design phase with the client or the designer, depending on the specific application, **making solutions modular and more efficient on a case-by-case basis**.



### CHILLED WATER

Chilled water units are available in several configurations and versions:

- **broad range of cooling capacity:** from 40 kW for TRF CW units to 350 kW for TRF CF units;
- **air flow:** several air flow configurations for the TRF CW models and fan module configurations for the TRF CS and TRF CF units are possible;

- **hydraulic circuit:** the configurations A, B and C have been developed to be able to choose the best option for the Data Center's actual operating conditions:
  - Geometry "A"**  
Designed to work with high water flow rates and  $\Delta T = 5^{\circ}\text{C}$ . Ideal for existing solutions
  - Geometry "B"**  
Designed to work with moderate water flow rates and  $\Delta T = 8^{\circ}\text{C}$ . Ideal for next-generation Data Centers
  - Geometry "C"**  
Designed to work with low water flow rates and  $\Delta T = 12^{\circ}\text{C}$ . Ideal for the very latest Data Centers

### Water Flow Control

All TRF units are equipped with valves for **water flow control**. In addition to 2-way or 3-way modulating valves, pressure-independent control valves (PICVs) or Energy Valves can be installed upon request.

**PICVs** offer several advantages, including reduced commissioning costs, as well as greater accuracy and stability in cooling capacity control.

**Energy Valves** also enable the measurement of water flow rate, inlet and outlet water temperatures, and the cooling capacity delivered by the unit. This data is transmitted to the controller and can be monitored via the display or the BMS.

Flexibility

Efficiency

Optimization  
of internal layout

Reduced  
footprint



# NRG

PERIMETER MOUNTED UNITS  
FOR DATA CENTRES  
WITH MODULATING COMPRESSORS



# TRF DX

PERIMETER MOUNTED UNITS  
FOR DATA CENTRES  
WITH ON-OFF COMPRESSORS



# TRF CW

CHILLED WATER  
PERIMETER-MOUNTED UNITS  
FOR DATA CENTERS



# TRF CS

CHILLED WATER  
PERIMETER-MOUNTED  
CONDITIONERS FOR  
DATA CENTERS WITH  
FANS - SLIM EDITION



# TRF CF

CHILLED WATER  
PERIMETER-MOUNTED  
CONDITIONERS FOR  
DATA CENTERS WITH  
UNDERFLOOR FANS

### Direct expansion

The TRF Evolution product family also includes the TRF DX and NRG **direct expansion** ranges: the former mounts on-off compressors on the whole range, the latter **inverter-driven modulating compressors**. The use of inverter technology allows the units in the NRG range to take their place among the **most energy-efficient and high-precision air-conditioning solutions**.

Depending on system requirements, it is possible to choose between an air- or water-cooled condensing unit during the offer phase. With **Dual Cooling** complete **redundancy** is possible thanks to the additional chilled water coil. Finally, with the **indirect water Free-Cooling** version, **energy consumption** can be minimized, taking advantage of low room temperatures to chill water without using the compressor.



# PERIMETER MOUNTED UNITS

Platform **TRF Evolution**

# TRF CW

## CHILLED WATER PERIMETER MOUNTED UNITS FOR DATA CENTERS

33-257 kW



MULTI-PROTOCOL COMMUNICATION INTERFACE	EC RADIAL FANS	MODBUS CONTROLLED FANS	PRESSURE INDEPENDENT VALVE (PIV)
FAST RESTART	ON-BOARD HUMIDIFIER	VARIABLE GEOMETRY COIL (FLEXY)	DOUBLE CIRCUIT

The chilled water air conditioners of the TRF CW series are particularly suitable for IT facilities where **temperature and air flow need to be continuously monitored**. The components of the TRF CW unit offer the most efficient solution for **Data Center cooling**, ensuring **reliability, precise control of thermo-hygrometric conditions** and the **flexibility** to adapt to different working conditions.

- Temperature control through heating and post-heating systems using electric heating elements, additional hot water coil or both
- Humidity control through dehumidification and humidification (optional)
- Fan speed modulation based on thermal load (constant  $\Delta T$ )
- Hydraulic connections from the bottom of the unit
- Broad choice of accessories, including base modules and plenums for ducting
- Air filter class G3 as standard. Air Filters G4, M5, F7 (optional)
- Double power supply with automatic switch (optional)
- Double panelling only on the front doors or on the whole machine (optional)
- Instant reading of water flow rate, water inlet and outlet temperatures, or supplied cooling capacity (optional)
- Harmonic filters (optional)

### CHILLED WATER

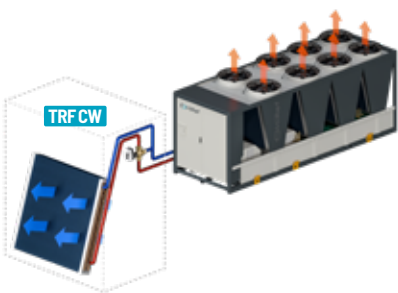

### Guaranteed flexibility

With three different types of heat exchangers, each optimised to a specific water  $\Delta T$  value (difference in water temperature between inlet/outlet), we ensure **high flexibility in adapting to the system or liquid chillers already in operation**, without compromising cooling performance:

- **Geometry A** for  $\Delta T = 5^{\circ}\text{C}$
- **Geometry B** for  $\Delta T = 8^{\circ}\text{C}$
- **Geometry C** for  $\Delta T = 12^{\circ}\text{C}$

### AIRFLOW CONFIGURATIONS

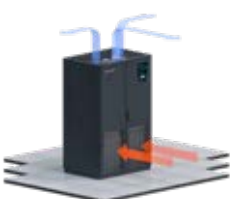

Upflow



Downflow

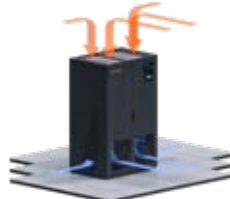

Displacement





**New design: efficiency, flexibility and optimization of internal layout**

Internal spaces have been completely redesigned for a **better distribution of components**. The new internal layout features a larger pack heat exchanger and a state-of-the-art fan for **maximum air flow and efficiency**. Following a **painstaking dynamic fluid study**, the filtering surface has also been expanded, now it is distributed over the entire coil to **further reduce air pressure drops**.

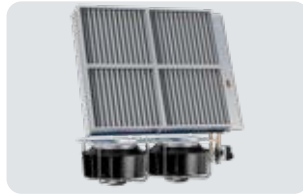

**Ventilation EC 2.0**

EC PLUG fans, standard throughout the range, are adjustable using different logics: flow rate, overpressure, constant  $\Delta P$  and  $\Delta T$ . Their accurate adjustment allows **an efficient use of power for ventilation and a consequent reduction of the system's PUE**. The speed, with extended range, is adjusted via the Modbus protocol. Finally, the "emergency speed" function allows for fan operation **even in the event of microprocessor malfunctions**.



**Finned pack coil with hydrophilic coating**

All models in the TRF CW range feature heat exchange coils with hydrophilic coating. This special coating - together with adequate adjustment of air through-flow speeds - **helps condensate collection and outflow during the dehumidification process, preventing any dripping on the inside and outside of the unit**.



**Accurate regulation with multiple types of valves**

All units in the TRF CW range have as standard regulating valves fitted with 0-10V servo motor, selectable in 2-way execution, with variable or 3-way flow system or with servo motor with spring return. On request, pressure-independent valves or Energy Valves can also be installed. All these types of valves **ensure the utmost adjustment accuracy while maintaining the system's hydronic balance**.

**Double circuit**

Chilled water units are also available with a double circuit. In this version, the supply is via **two different hydraulic circuits** that can offer the **utmost operational continuity if one of the two circuits malfunctions**. Each circuit is equipped with a regulating valve.



TRF CW	040	060	070	080	090	100	110	130	150	170	180	210	240	
<b>Version A</b>	<b>Air temperature 24°C - 50% / Water temperature In 7°C Out 12°C</b>													
Cooling capacity kW	38.1	58	64.4	80.8	85.3	105.5	103.1	137.2	137.8	177.2	172	226.9	257.1	
EER	31.07	39.97	33.28	37.31	34.93	40.41	33.65	40.43	30.81	36.02	33.3	39.51	34.82	
SHR	0.86	0.79	0.82	0.78	0.81	0.77	0.83	0.77	0.82	0.77	0.82	0.76	0.74	
<b>Version A</b>	<b>Air temperature 30°C - 35% / Water temperature In 10°C Out 15°C</b>													
Cooling capacity kW	43.3	59.6	67.9	80.8	89.9	104	112.3	133.7	148.4	172.7	185.2	219.7	236.3	
EER	35.36	41.06	35.05	37.33	36.82	39.84	36.66	39.41	33.18	35.11	35.86	38.25	32.01	
SHR	1.00	0.99	1	0.99	1	0.97	1	0.99	1	0.99	1	0.98	0.94	
<b>Version B</b>	<b>Air temperature 30°C - 35% / Water temperature In 10°C Out 18°C</b>													
Cooling capacity kW	38.9	55.2	63.3	74.8	82.4	98.4	104.8	126.3	135.3	163.1	169	203.6	229.5	
EER	31.69	38	32.69	34.54	33.73	37.69	34.19	37.2	30.27	33.15	32.71	35.45	31.08	
SHR	1	1	1	1	1	1	1	1	1	1	1	1	0.96	
<b>Version C</b>	<b>Air temperature 30°C - 35% / Water temperature In 10°C Out 22°C</b>													
Cooling capacity kW	33.4	49.8	54.4	67.5	73.2	87.6	90.1	111.8	116.3	144.4	145.2	180.3	210.2	
EER	27.23	34.32	28.1	31.2	30	33.55	29.39	32.94	26.02	29.35	28.12	31.39	28.47	
SHR	1	1	1	1	1	1	1	1	1	1	1	1	1	
<b>Version A</b>	<b>Air temperature 35°C - 30% / Water temperature In 15°C Out 20°C</b>													
Cooling capacity kW	43.7	58.6	68.2	80.2	89.3	102.3	112.9	133.9	145.8	172.9	182	215.9	237.5	
EER	35.65	40.36	35.22	37.03	36.57	39.16	36.84	39.46	32.61	35.16	35.24	37.6	32.17	
SHR	1	1	1	1	1	1	1	1	1	1	1	1	1	
<b>Version B</b>	<b>Air temperature 35°C - 30% / Water temperature In 15°C Out 23°C</b>													
Cooling capacity kW	39.1	55	63.4	75.3	82.4	98.1	104.9	125.9	135.5	162.6	169.2	203	228.4	
EER	31.89	37.91	32.74	34.8	33.74	37.56	34.24	37.1	30.31	33.06	32.76	35.36	30.94	
SHR	1	1	1	1	1	1	1	1	1	1	1	1	1	
<b>Version C</b>	<b>Air temperature 35°C - 30% / Water temperature In 15°C Out 27°C</b>													
Cooling capacity kW	33.9	50.1	56.5	67.9	73.9	87.9	91	112.3	117.6	145.1	146.8	181.1	210.6	
EER	27.67	34.49	29.17	31.35	30.24	33.68	29.7	33.1	26.29	29.49	28.41	31.54	28.52	
SHR	1	1	1	1	1	1	1	1	1	1	1	1	1	
Rated air flow m <sup>3</sup> /h	10700	10700	14500	14500	18000	18000	24000	24000	18000	18000	24000	24000	31000	
Total fan absorbed power kW	1.2	1.5	1.9	2.2	2.4	2.6	3.1	3.4	4.5	4.9	5.2	5.7	7.4	
Power supply V/ph/Hz	400/3+N/50													
Lp @ Nominal rpm ; dist.= 2 m Q=2 dB(A)	61	67		72		66	67	71	72	69	70	71		
Dimensions [LxHxD] mm	1010x2000x890		1270x2000x890		1760x2000x890		2020x2000x890		2510x2000x890		3160x2000x890			3160x2000x960

Performance data relating to Downflow versions. | Also available with 60 Hz power supply. | Units also available in the models Upflow and Displacement, with the exception of size 240. | Height of model Displacement 2250 mm.

**Ventilation adjustment**

Depending on the air distribution logic in the server room, it is possible to adjust the machine on-board ventilation system to ensure a **constant air flow rate** (airflow control) or a **constant available overpressure** ( $\Delta P$  control). The latter is particularly useful if a floating floor is used.



**Easier scheduled maintenance**

The unit has been painstakingly designed to ensure frontal access to components. This makes **routine maintenance easier in full compliance with safety standards**.

Platform **TRF Evolution**

# TRF CS

## CHILLED WATER PERIMETER MOUNTED AIR CONDITIONING UNITS FOR DATA CENTER WITH UNDERFLOOR FANS - SLIM EDITION

58-242 kW



MULTI-PROTOCOL COMMUNICATION INTERFACE	EC RADIAL FANS	MODBUS CONTROLLED FANS	PRESSURE INDEPENDENT VALVE (PICV)
FAST RESTART	ON-BOARD HUMIDIFIER	VARIABLE GEOMETRY COIL (FLEXY)	DOUBLE CIRCUIT

TRF CS is the range of chilled-water air conditioners **for high power density computer rooms**. The fans of the TRF CS units are positioned in separate housing (so-called FREE FAN solution), **to increase the overall cooling capacity of the unit**, but not to the detriment of the depth, which remains 890 mm. Great care has gone into every detail, in order **to minimize air flow pressure drops and energy consumption of the fans**, the only electrical load present in the machine.

- Temperature control through heating and post-heating systems with electric heating elements (optional)
- Humidity control through dehumidification and humidification (optional)
- Fan speed modulation based on thermal load (constant  $\Delta T$ )
- Hydraulic connections from the bottom of the unit
- Broad choice of accessories, including plenums for ducting, plenums for direct Free-Cooling
- Air filter class G3 as standard. Air Filters G4, M5, F7 (optional)
- Double power supply with automatic switch (optional)
- Double panelling only on the front doors or on the whole machine (optional)
- Instant reading of water flow rate, water inlet and outlet temperatures, or supplied cooling capacity (optional)
- Harmonic filters (optional)

### CHILLED WATER

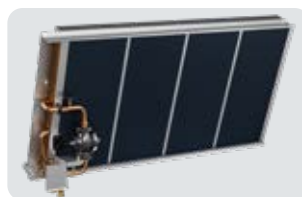
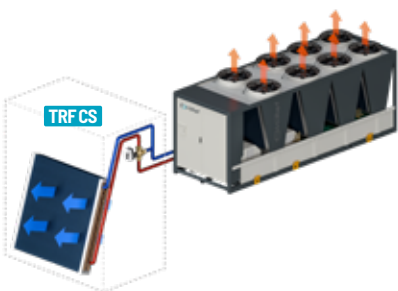

### Finned pack coil with hydrophilic coating

All models in the TRF CS range feature heat exchange coils with hydrophilic coating. This special coating - together with adequate adjustment of air through-flow speeds - **helps condensate collection and outflow during the dehumidification process, preventing any dripping on the inside and outside of the unit.**

### AIRFLOW CONFIGURATIONS





**FREE FAN solution**

The FREE FAN solution with the fans mounted in separate housing **freed up space inside the unit and thus increases the surface area of the coil.** This results in both an **increase in air flow and cooling capacity and a reduction in air pressure drops.** The **FREE FAN** solution increases the refrigerating power of the entire range.

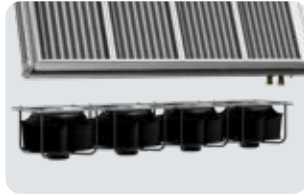
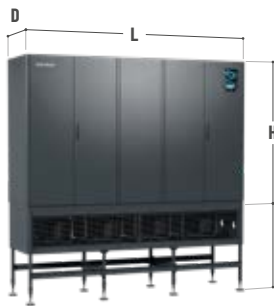

**Ventilation EC 2.0**

EC PLUG fans, standard throughout the range, are adjustable using different logics: flow rate, overpressure, constant  $\Delta P$  and  $\Delta T$ . Their accurate adjustment allows **an efficient use of power for ventilation and a consequent reduction of the system's PUE.** Extended range speed adjustment is carried out via Modbus protocol. The "emergency speed" function allows for fan operation **even in the event of microprocessor malfunctions.**



**Accurate regulation with multiple types of valves**

All units in the TRF CS range have as standard regulating valves fitted with 0-10V servo motor, selectable in 2-way execution, with variable or 3-way flow system or with servo motor with spring return. On request, pressure-independent valves or Energy Valves can also be installed. All these types of valves **ensure the utmost adjustment accuracy while maintaining the system's hydronic balance.**



**Ventilation adjustment**

Depending on the air distribution logic in the server room, it is possible to adjust the machine on-board ventilation system to ensure a **constant air flow rate** (airflow control) or a **constant available overpressure** ( $\Delta P$  control). The latter is particularly useful if a floating floor is used.



**Extended filter section**

Air filters, located on the entire surface of the coil, **maximize the filtering section and minimize the unit's air pressure drops.**

TRF CS		045	055	065	075	150	180	200	210
<b>Version A</b>		<b>Air temperature 24°C - 50% / Water temperature In 7°C Out 12°C</b>							
Cooling capacity	kW	68.9	81.8	104.7	131.2	165.3	200.5	-	-
EER		26.92	29.21	31.38	35.17	35.68	38.28	-	-
SHR		0.82	0.8	0.82	0.78	0.8	0.78	-	-
<b>Version A</b>		<b>Air temperature 30°C - 35% / Water temperature In 10°C Out 15°C</b>							
Cooling capacity	kW	72.6	84.8	110.2	131.2	172.3	200.6	-	-
EER		28.35	30.26	33.05	35.19	37.19	38.29	-	-
SHR		1	1	1	0.99	1	0.99	-	-
<b>Version B</b>		<b>Air temperature 30°C - 35% / Water temperature In 10°C Out 18°C</b>							
Cooling capacity	kW	66	79.9	102.8	121.4	157.2	189.4	205.2	242.4
EER		25.81	28.53	30.82	32.56	33.93	36.15	29.64	31.42
SHR		1	1	1	1	1	1	1	1
<b>Version C</b>		<b>Air temperature 30°C - 35% / Water temperature In 10°C Out 22°C</b>							
Cooling capacity	kW	58.2	70.6	88.4	109.7	135.1	167.7	176.4	218.9
EER		22.73	25.2	26.5	29.41	29.17	32	25.48	28.38
SHR		1	1	1	1	1	1	1	1
<b>Version A</b>		<b>Air temperature 35°C - 30% / Water temperature In 15°C Out 20°C</b>							
Cooling capacity	kW	72.9	84.9	110.8	130.2	173	199	-	-
EER		28.49	30.3	33.21	34.91	37.35	37.98	-	-
SHR		1	1	1	1	1	1	-	-
<b>Version B</b>		<b>Air temperature 35°C - 30% / Water temperature In 15°C Out 23°C</b>							
Cooling capacity	kW	67.8	79.7	103	121.2	157.4	188.9	205.5	241.8
EER		26.48	28.47	30.87	32.49	33.98	36.05	29.69	31.35
SHR		1	1	1	1	1	1	1	1
<b>Version C</b>		<b>Air temperature 35°C - 30% / Water temperature In 15°C Out 27°C</b>							
Cooling capacity	kW	58.8	71	89.3	110.2	136.5	168.5	178.2	220
EER		22.97	25.33	26.77	29.55	29.47	32.16	25.75	28.52
SHR		1	1	1	1	1	1	1	1
Rated air flow	m <sup>3</sup> /h	15500	15500	23550	23550	36000	36000	47000	47000
Total fan absorbed power	kW	2.6	2.8	3.3	3.7	4.6	5.2	6.9	7.7
Power supply	V/ph/Hz	400/3+N/50							
Lp @ Nominal rpm ; dist.= 2 m Q=2	dB(A)	69		66		67		68	
Dimensions [LxHxD]	mm	1270x2000x890		1760x2000x890		2510x2000x890		3160x2000x890	

Also available with 60 Hz power supply. | Minimum height with fanmodule 2550 mm.



**Easier scheduled maintenance**

The unit has been painstakingly designed to ensure frontal access to components. This makes **routine maintenance easier in full compliance with safety standards.**

**Double circuit**

Chilled water units are also available with a double circuit. In this version the supply is **via two different hydraulic circuits** that can offer the **utmost operational continuity if one of the two circuits malfunctions.** Each circuit is equipped with a regulating valve

Platform **TRF Evolution**

# TRF CF

## CHILLED WATER PERIMETER MOUNTED UNITS FOR DATA CENTERS WITH UNDERFLOOR FANS

78-329 kW



 MULTI-PROTOCOL COMMUNICATION INTERFACE	 VENTILATORI EC RADIALI	 VENTILATORI CONTROLLATI IN MODBUS	 PRESSURE INDEPENDENT VALVE (PICV)
 FAST RESTART	 ON-BOARD HUMIDIFIER	 VARIABLE GEOMETRY COIL (FLEXY)	 DOPPIO CIRCUITO

TRF CF is the range of chilled-water air conditioners for computer rooms **with very high power density**. As for the TRF CS range, the fans are mounted in separate housing, but in addition units are **equipped with two chilled water batteries**. With these solutions the **cooling capacity is maximized**, at the same depth of 960 mm. In-depth fluid dynamic analysis has resulted in the meticulous design of every last constructive detail **to minimise air pressure drops and fan power consumption**, the only power load in the machine.

- Temperature control through heating and post-heating systems with electric heating elements (optional)
- Humidity control through dehumidification and humidification (optional)
- Fan speed modulation based on thermal load (constant  $\Delta T$ )
- Hydraulic connections from the bottom of the unit
- Broad choice of accessories, including plenums for ducting, plenums for direct Free-Cooling
- Air filter class G3 as standard. Air Filters G4, M5, F7 (optional)
- Double power supply with automatic switch (optional)
- Double panelling only on the front doors or on the whole machine (optional)
- Instant reading of water flow rate, water inlet and outlet temperatures, or supplied cooling capacity (optional)
- Harmonic filters (optional)

### CHILLED WATER

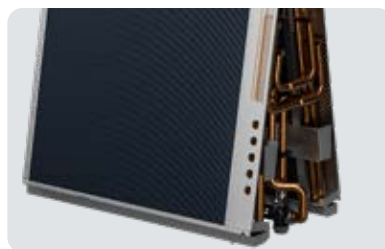
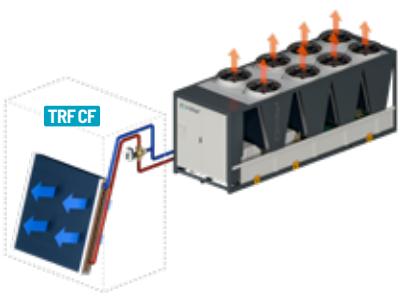

### Finned pack coil with hydrophilic coating

All models in the TRF CF range feature heat exchange coils with hydrophilic coating. This special coating - together with adequate adjustment of air through-flow speeds - **helps condensate collection and outflow during the dehumidification process, preventing any dripping on the inside and outside of the unit.**

### AIRFLOW CONFIGURATIONS



Free Fan



**FREE FAN solution**

The FREE FAN solution with the fans mounted in separate housing frees up space inside the unit and thus **increases the surface area of the coil**. This results in both an **increase in air flow and cooling capacity and a reduction in air pressure drops**. The **FREE FAN solution increases the refrigerating power of the entire range**.



**Ventilation EC 2.0**

EC PLUG fans, standard throughout the range, are adjustable using different logics: flow rate, overpressure, constant  $\Delta P$  and  $\Delta T$ . Their accurate adjustment allows an **efficient use of power for ventilation and a consequent reduction of the system's PUE**. Extended range speed adjustment is carried out via Modbus protocol. The "emergency speed" function allows for fan operation **even in the event of microprocessor malfunctions**.



**Accurate regulation with multiple types of valves**

All units in the TRF CS range have as standard regulating valves fitted with 0-10V servo motor, selectable in 2-way execution, with variable or 3-way flow system or with servo motor with spring return. On request, pressure-independent valves or Energy Valves can also be installed. All these types of valves **ensure the utmost adjustment accuracy while maintaining the system's hydronic balance**.



**Ventilation adjustment**

The most suitable on-board ventilation system can be chosen based on the air distribution logic in the server room, guaranteeing **a constant flow of air** (air flow control) **or a constant available overlap** ( $\Delta p$  control); the latter is particularly useful when using a floating floor.

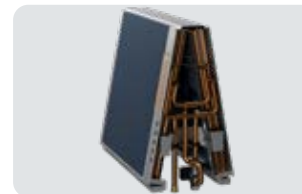

**Double coil**

The double coil solution is designed to optimize the internal spaces of the unit, **significantly increasing the heat exchange surface and potential refrigerating power**.

TRF CF	045	055	065	075	150	180	200	210	
<b>Version A</b>	<b>Air temperature 24°C - 50% / Water temperature In 7°C Out 12°C</b>								
Cooling capacity kW	92.8	111.2	154.5	191.2	234.5	-	-	-	
EER	33.56	38.75	26.02	30.55	24.78	-	-	-	
SHR	0.77	0.73	0.78	0.74	0.78	-	-	-	
<b>Version A</b>	<b>Air temperature 30°C - 35% / Water temperature In 10°C Out 15°C</b>								
Cooling capacity kW	91.1	102.4	154	176.7	233.7	-	-	-	
EER	32.94	35.68	25.93	28.23	24.7	-	-	-	
SHR	1	0.93	1	0.94	1	-	-	-	
<b>Version B</b>	<b>Air temperature 30°C - 35% / Water temperature In 10°C Out 18°C</b>								
Cooling capacity kW	85.9	97.9	141.8	164.6	219.8	254.3	283.7	329.2	
EER	31.06	34.14	23.88	26.31	23.23	25.54	22.07	24.28	
SHR	1	0.95	1	0.98	1	0.97	1	0.98	
<b>Version C</b>	<b>Air temperature 30°C - 35% / Water temperature In 10°C Out 22°C</b>								
Cooling capacity kW	77.6	90.6	127.2	153.2	193	232.5	254.4	300.4	
EER	28.06	31.59	21.41	24.49	20.4	23.35	19.79	22.16	
SHR	1	1	1	1	1	1	1	1	
<b>Version A</b>	<b>Air temperature 35°C - 30% / Water temperature In 15°C Out 20°C</b>								
Cooling capacity kW	91.2	100.5	154.4	173.6	234.2	-	-	-	
EER	32.99	35.03	25.99	27.75	24.75	-	-	-	
SHR	1	1	1	1	1	-	-	-	
<b>Version B</b>	<b>Air temperature 35°C - 30% / Water temperature In 15°C Out 23°C</b>								
Cooling capacity kW	85.7	96.6	141.7	163.9	219.5	253.2	283.4	327.9	
EER	30.99	33.68	23.85	26.2	23.2	25.43	22.05	24.18	
SHR	1	1	1	1	1	1	1	1	
<b>Version C</b>	<b>Air temperature 35°C - 30% / Water temperature In 15°C Out 27°C</b>								
Cooling capacity kW	78	89.9	128	153.6	194.2	233	256	301.2	
EER	28.19	31.35	21.55	24.54	20.53	23.41	19.92	22.22	
SHR	1	1	1	1	1	1	1	1	
<b>Rated air flow</b>	m <sup>3</sup> /h	16500	16500	29000	29000	44000	44000	5800	5800
<b>Total fan absorbed power</b>	kW	2.8	2.9	5.9	6.3	9.5	10	12.9	13.6
<b>Power supply</b>	V/ph/Hz	400/3+N/50						400/3+N/50	400/3+N/50
<b>Lp @ Nominal rpm ; dist.= 2 m Q=2</b>	dB(A)	70		71		73		74	75
<b>Dimensions [LxHxD]</b>	mm	1270x2000x960		1760x2000x960		2510x2000x960		3160 x2000 x960	3160 x2000 x960

Also available with 60 Hz power supply. | Minimum height with fanmodule 2550 mm.



**Easier scheduled maintenance**

The unit has been painstakingly designed to ensure frontal access to components. This makes **routine maintenance easier in full compliance with safety standards**.

**Double circuit**

Chilled water units are also available with a double circuit. In this version the supply is **via two different hydraulic circuits** that can offer the **utmost operational continuity if one of the two circuits malfunctions**. Each circuit is equipped with a regulating valve

Platform **TRF Evolution**

# TRF DX A

## AIR CONDENSED PERIMETER MOUNTED UNITS FOR DATA CENTERS

24-160 kW



MULTI-PROTOCOL COMMUNICATION INTERFACE	SCROLL COMPRESSORS	EC RADIAL FANS	MODBUS CONTROLLED FANS
FAST RESTART	ON-BOARD HUMIDIFIER	MODULATING HOT GAS POST-HEATING	LOW GWP REFRIGERANT

The TRF DX series perimeter mounted units are direct expansion units with Scroll on-off compressors designed to be installed in medium/large-sized premises such as server rooms and labs or for applications where **accurate control of thermo-hygrometric parameters and round-the-clock operation are required**. The top priority for internal design and for the choice of components is **energy efficiency to optimise the system overall electricity** consumption with a positive impact on the Data Center Power Usage Effectiveness (PUE). Versatile and flexible range

TRF DX A units are air-condensed perimeter-mounted units in the TRF range; they are widely used for the cooling of Data Centers. The air-condensed solution offers a **simple system design**, thanks to the absence of auxiliary circuits and pumps; **the cooling circuit is managed by the cabinet**, and both the indoor unit and the remote condenser are **easy to install**.

- Refrigerant R410A or R513A
- EC Fans
- Scroll on/off compressors
- Temperature control through heating and post-heating systems with electric heating elements, hot water and hot gas (optional)
- Humidity control through dehumidification and humidification (optional)
- Broad choice of accessories, including base modules and plenums for ducting
- Air filter class G3 as standard. Air Filters G4, M5, F7 (optional)
- Double power supply with automatic switch (optional)
- Constant-flow (airflow control) or constant available overpressure ( $\Delta P$  control) ventilation modulation (optional)
- Electronic expansion valves (optional)
- Low temperature kits for optimal operation in the case of installation in particularly cold environments (on request)
- Long distance kits for optimal operation in the event of large distances between indoor and outdoor units (on request)

### AIR CONDENSED

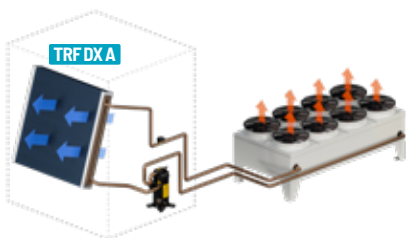

#### Green

HiRef is constantly striving to find refrigerants with an ever decreasing environmental impact. The use of ASHRAE class A1, non-toxic and non-flammable refrigerants is essential in close control applications.

### AIRFLOW CONFIGURATIONS

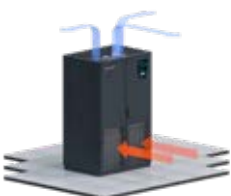

Upflow



Downflow



Displacement



**Easier scheduled maintenance**

The unit has been painstakingly designed to ensure frontal access to components. This makes **routine maintenance easier in full compliance with safety standards.**



**Efficiency**

The performance, reliability and efficiency of HiRef units are guaranteed **by using the best quality components and by cleverly designed internal and external layouts.**



**Remote condensers**

All units can be combined with HiRef remote condensers, choosing from **different combinations to meet all system needs.** **Oversize remote condensers** are ideal for warmer environments, where it is necessary to keep the condensing temperature under control, while **the compact condensers** on the other hand are small in terms of both size and consumption. The condensers, used with dual-circuit units, are available with a single cooling circuit for **maximum reliability and redundancy of the system** or with a double cooling circuit, **to reduce installation spaces and costs.**

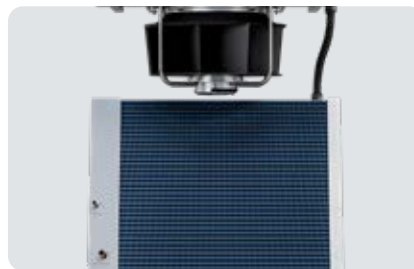

**Safety in the server room**

All models in the TRF DX A range feature heat exchange coils with hydrophilic coating as standard. This special coating - together with an adequate selection of air through-flow speeds - **aids condensate collection during the dehumidification process, preventing any dripping on the inside and outside of the unit.**

**Dual circuit**

Double-circuit versions are already available at low power levels. This solution offers **maximum unit redundancy and ensures continuity of service, more precise refrigerating power and less absorption for partial Data Center loads.**

TRF DX A	0241	0261	0291	0331	0361	0391	0441	0481	0521	0382	0432	0492	0532	0602	0632	0682	0762	0802	0872	0962	1204	1304			
<b>R410A - Indoor air 24°C - 50% / Outdoor air 35°C</b>																									
Cooling capacity	kW	23.9	26.4	29.5	33.5	36.5	39.9	44.3	48.6	52.4	38.7	43.4	48.6	53.7	61.2	64.2	69.7	78	81.6	89.5	98.2	122.1	134		
Total absorbed power	kW	7.2	7.9	8.8	9.5	10	11.5	12.6	13.6	15.1	11	13.2	14.5	15.9	17.7	19.2	21.1	23.5	25.2	28.5	30.7	35.9	40.5		
EER		4	3.99	3.89	4.34	4.41	4.08	4.09	4.44	4.22	4.63	4.13	4.09	4.05	4.06	4.22	4.05	3.99	4.23	3.96	3.95	4.07	3.87		
SHR		1	1	1	1	1	1	0.95	1	1	1	1	1	1	0.92	1	1	0.92	1	0.99	0.93	0.93	0.88		
<b>R410A - Indoor air 30°C - 35% / Outdoor air 35°C</b>																									
Cooling capacity	kW	27.3	29.7	33.1	38.1	41.3	44.8	48.8	54.8	59	44.1	49.5	55.7	60.5	67.8	72.5	78.3	86.1	92.1	99.9	107.9	135.9	145.6		
Total absorbed power	kW	7.4	8	9	9.7	10.1	11.8	12.9	13.9	15.4	11.3	13.6	15	16.3	18.1	19.5	21.3	23.9	25.7	29.1	31.2	36.3	41.3		
EER		4.39	4.37	4.25	4.83	4.94	4.45	4.4	4.89	4.62	5.11	4.5	4.51	4.44	4.39	4.64	4.51	4.31	4.64	4.3	4.26	4.46	4.11		
SHR		1	0.99	1	1	1	1	1	1	1	1	1	1	1	1	1	1	1	1	1	1	1	0.99		
<b>R410A - Indoor air 35°C - 30% / Outdoor air 35°C</b>																									
Cooling capacity	kW	29.8	32.7	36.3	41.8	45.2	48.9	53.5	60.1	64.6	47.2	54	60.9	66.5	74.3	79.8	85.5	93.9	101.5	108.9	118.6	148.7	160.1		
Total absorbed power	kW	7.6	8.2	9.1	9.8	10.3	12.1	13.1	14.1	15.8	11.5	14	15.4	16.4	18.3	19.8	21.7	24.5	25.9	29.6	31.6	36.9	41.7		
EER		4.71	4.7	4.61	5.19	5.31	4.74	4.73	5.24	4.93	5.36	4.77	4.79	4.82	4.75	5.03	4.83	4.57	5.06	4.58	4.61	4.79	4.47		
SHR		1	1	1	1	1	1	1	1	0.85	1	1	1	1	1	1	1	1	1	1	1	1	1		
<b>R513A - Indoor air 30°C - 35% / Outdoor air 35°C</b>																									
Cooling capacity	kW	26.3	29.8	32.1	37.4	42.3	-	-	46.7	-	-	51.5	56.6	61.9	-	71.5	80.5	-	87.4	-	-	102.8	123.3		
Total absorbed power	kW	6.6	7.3	8.2	9.9	11.3	-	-	12	-	-	13.5	15.7	16.2	-	19.7	22.2	-	24.2	-	-	27.7	34.1		
EER		5.03	5.03	4.72	4.69	4.52	-	-	5.11	-	-	5	4.57	4.63	-	4.53	4.41	-	4.8	-	-	4.95	4.54		
SHR		1	0.99	1	1	0.99	-	-	1	-	-	1	0.99	1	-	1	1	-	1	-	-	0.99	1		
<b>R513A - Indoor air 35°C - 30% / Outdoor air 35°C</b>																									
Cooling capacity	kW	29.3	33.2	35.5	41.4	46.9	-	-	51.9	-	-	57.3	62.8	68.4	-	79	89.1	-	96.9	-	-	114.3	136.1		
Total absorbed power	kW	6.8	7.5	8.5	10.3	11.7	-	-	12.3	-	-	13.5	15.7	16.7	-	20.3	22.8	-	24.9	-	-	28.5	35.2		
EER		5.39	5.39	5.03	4.95	4.81	-	-	5.46	-	-	5.36	4.89	4.93	-	4.82	4.73	-	5.11	-	-	5.3	4.83		
SHR		1	1	0.99	1	1	-	-	0.99	-	-	1	1	1	-	1	1	-	1	-	-	0.99	1		
Rated air flow	m³/h	8800			11800			15500			19900			25300			32100								
Power supply	V/ph/Hz							400/3+N/50																	
Number of circuits		1	1	1	1	1	1	1	1	1	2	2	2	2	2	2	2	2	2	2	2	2	2		
Lp @ nominal rpm; dist.=2m Q=2	db(A)	61	62	63	66	66	67	67	71	71	71	71	71	71	71	71	71	71	71	71	71	71	71		
Dimensions [LxHxD]	mm	1010x2000x890			1270x2000x890			1760x2000x890			2020x2000x890			2510x2000x890			3160x2000x960								

Also available with 60 Hz power supply. | Height of model Displacement 2250 mm.

Platform **TRF Evolution**

# TRF DX W/Z



## WATER CONDENSED PERIMETER MOUNTED UNITS FOR DATA CENTERS

TRF DX W > 24-165 kW

TRF DX Z > 28-185 kW

 LOW GWP REFRIGERANT	 MULTI-PROTOCOL COMMUNICATION INTERFACE	 SCROLL COMPRESSORS
 EC RADIAL FANS	 MODBUS CONTROLLED FANS	 FAST RESTART
 ON-BOARD HUMIDIFIER	 MODULATING HOT GAS POST-HEATING	 PLATE HEAT EXCHANGER

TRF DX W units are water-condensed perimeter-mounted cabinets that use Dry Cooler water. The TRF units of this series are "monobloc" units inside which **the entire cooling circuit is concentrated**. Cooling is via a **brazed-plate exchanger made of stainless steel AISI 304**.

TRF DX Z units are water-condensed perimeter-mounted cabinets that use low temperature mains water or groundwater (15°C). The TRF units of this series are "monobloc" units inside which **the entire cooling circuit is concentrated**. Cooling is via a **brazed-plate exchanger made of stainless steel AISI 304**.

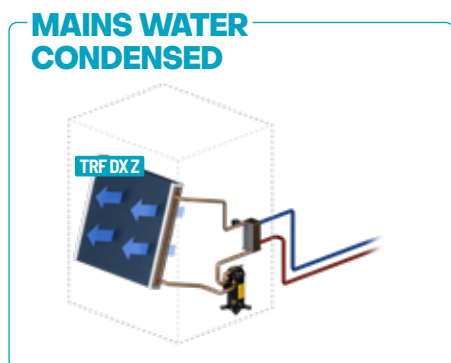
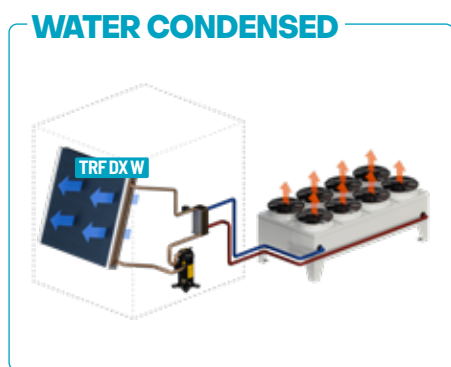

**Easier scheduled maintenance**

The unit has been painstakingly designed to ensure frontal access to components even with the units running. This makes **routine maintenance easier in full compliance with safety standards**.

**Safety in the server room**

All models in the TRF DX W range feature heat exchange coils with hydrophilic coating as standard. This special coating - together with an adequate selection of air through-flow speeds - **aids condensate collection during the dehumidification process, preventing any dripping on the inside and outside of the unit**.

- Refrigerant R410A or R513A
- EC Fans
- Scroll on/off compressors
- Temperature control through heating and post-heating systems with electric heating elements, hot water and hot gas (optional)
- Humidity control through dehumidification and humidification (optional)
- Low temperature kits for optimal operation in the case of installation in particularly cold environments (on request)
- Broad choice of accessories, including base modules and plenums for ducting
- Air filter class G3 as standard. Air Filters G4, M5, F7 (optional)
- Double power supply with automatic switch (optional)
- Constant-flow (airflow control) or constant available overpressure ( $\Delta P$  control) ventilation modulation (optional)
- Electronic expansion valves (optional)



**AIRFLOW CONFIGURATIONS**

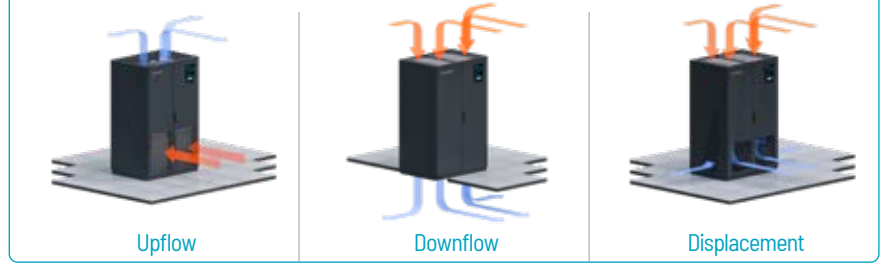

**Efficiency**

The performance, reliability and efficiency of HiRef units are guaranteed **by using the best quality components and by cleverly designed internal and external layouts.**

**Dual circuit**

Double-circuit versions are already available at low power levels. This solution offers **maximum unit redundancy and ensures continuity of service, more precise refrigerating power and less absorption for partial Data Center loads.**

**Green**

HiRef is constantly striving to find **refrigerants with an ever decreasing environmental impact.** The use of ASHRAE class A1, non-toxic and non-flammable refrigerants is essential in close control applications.

TRF DX W		0241	0261	0291	0331	0361	0391	0441	0481	0521	0382	0432	0492	0532	0602	0632	0682	0762	0802	0872	0962	1204	1304		
<b>R410A - Indoor air 30°C - 35% / Water 40°C - 45°C</b>																									
Cooling capacity	kW	28.4	31.4	34.2	40	42.1	46.8	50.2	56.9	61.2	45.3	52.5	57.4	63.9	70.1	76.3	81.5	89.2	95.6	105.1	111.7	138.4	150.3		
Total absorbed power	kW	6.9	7.3	8.4	8.8	9.7	10.8	12.1	12.9	14.3	10.7	12.3	14	14.7	17	17.9	19.7	22.2	24	26.6	29.4	35.2	39		
EER		5	5.22	4.74	5.69	5.32	5.16	4.84	5.52	5.23	5.84	5.46	5.05	5.32	4.89	5.46	5.18	4.88	5.27	5.06	4.75	4.71	4.54		
SHR		1	1	1	1	1	1	1	1	1	1	1	1	1	1	1	1	1	1	1	1	1	1		
<b>R410A - Indoor air 35°C - 30% / Water 40°C - 45°C</b>																									
Cooling capacity	kW	31.3	34.8	37.8	44.5	46.8	51.7	55.4	63.2	68	49.9	57.9	63.6	70.6	77.6	84.3	90.4	98.8	106.3	116	122.6	153.1	165.1		
Total absorbed power	kW	6.9	7.1	8.3	8.6	9.5	10.7	12	12.8	14.2	10.7	12.3	14	14.4	16.8	17.6	19.4	22.1	23.7	26.4	29.2	34.9	38.6		
EER		5.53	5.91	5.31	6.47	6.05	5.79	5.4	6.23	5.88	6.22	6.03	5.59	5.99	5.47	6.15	5.86	5.45	5.95	5.65	5.24	5.27	5.04		
SHR		1	1	1	1	1	1	1	1	1	1	1	1	1	1	1	1	1	1	1	1	1	0.99		
<b>R513A - Indoor air 30°C - 35% / Water 40°C - 45°C</b>																									
Cooling capacity	kW	26.5	29.6	32	37.8	42.5	-	-	46.4	-	-	51.8	57.8	62	-	72.8	80.7	-	87.2	-	-	103.3	122.6		
Total absorbed power	kW	6.5	7.4	8.2	9.7	11.2	-	-	12	-	-	13	14.8	16.1	-	19	22	-	24.1	-	-	27.6	34.3		
EER		5.16	4.9	4.69	4.85	4.55	-	-	5.04	-	-	5.09	4.84	4.66	-	4.82	4.48	-	4.8	-	-	5	4.48		
SHR		1	1	1	1	1	-	-	0.99	-	-	1	1	1	-	1	1	-	1	-	-	1	1		
<b>R513A - Indoor air 35°C - 30% / Water 40°C - 45°C</b>																									
Cooling capacity	kW	29.8	33.1	35.8	42.3	47.5	-	-	52.5	-	-	58	64.5	69.1	-	81.4	90.4	-	98	-	-	116	137.1		
Total absorbed power	kW	6.6	7.5	8.3	9.8	11.4	-	-	12.2	-	-	13.1	14.9	16.3	-	19.2	22.2	-	24.4	-	-	27.9	34.6		
EER		5.71	5.41	5.18	5.35	5.03	-	-	5.6	-	-	5.63	5.33	5.13	-	5.32	4.94	-	5.3	-	-	5.54	4.96		
SHR		0.99	0.99	0.99	1	0.99	-	-	1	-	-	0.98	1	1	-	1	1	-	1	-	-	1	1		
Rated air flow	m³/h	8800				11800				15500				19900				25300				32100			
Power supply	V/ph/Hz	400/3+N/50																							
Number of circuits		1	1	1	1	1	1	1	1	1	2	2	2	2	2	2	2	2	2	2	2	2	2		
Lp @ nominal rpm; dist.=2m Q=2	db(A)	61	62	63	66	66	67	67	71	71	71	71	71	71	71	66	66	66	69	69	69	66	66		
Dimensions [LxHxD]	mm	1010x2000x890				1270x2000x890				1760x2000x890				2020x2000x890				2510x2000x890				3160x2000x960			
<b>TRF DX Z</b>																									
<b>R410A - Indoor air 30°C - 35% / Water 15°C - 30°C</b>																									
Cooling capacity	kW	32.1	35.3	38.3	45.2	47.3	52.3	56.6	64.2	68.9	52	59.8	65	71.3	77.7	84.9	90.3	99	106.9	117.9	125.1	155.2	169.3		
Total absorbed power	kW	5.4	5.1	6.1	6.2	6.9	7.7	8.7	9.4	10.6	8.5	9.7	10.9	10.5	12.5	13.1	14.5	16.5	17.5	19.7	22.1	25.3	27.9		
EER		7.78	9.14	7.92	10.24	9.25	8.88	8.14	9.5	8.64	8.97	8.55	7.86	9.07	7.9	9.22	8.55	7.89	9.21	8.52	7.72	8	7.69		
SHR		0.99	1	1	1	0.98	1	1	1	1	0.99	1	1	1	1	1	1	1	1	1	1	1	0.97		
<b>R410A - Indoor air 35°C - 30% / Water 15°C - 30°C</b>																									
Cooling capacity	kW	35.5	38.6	42	49.9	52.1	57.4	62.1	70.3	75.6	57.4	65.9	72	78.3	85.3	93.7	99.8	108.8	118.1	130.1	137.3	170.3	184.7		
Total absorbed power	kW	5.4	4.8	5.8	5.8	6.6	7.3	8.5	9.1	10.4	8.4	9.7	10.9	10.1	12.1	12.6	14	15.9	16.7	19.1	21.6	24.4	27.2		
EER		8.59	10.7	9.12	12.24	10.88	10.35	9.25	10.88	9.8	9.92	9.39	8.7	10.56	9.05	10.87	9.96	9.1	10.93	9.81	8.71	9.19	8.68		
SHR		1	0.98	1	1	0.99	1	1	0.98	1	1	1	1	1	1	1	1	1	1	1	1	1	1		
<b>R513A - Indoor air 30°C - 35% / Water 15°C - 30°C</b>																									
Cooling capacity	kW	29.3	32.7	35.4	41.8	47.2	-	-	51.6	-	-	57	63.7	68.1	-	80.5	88.7	-	97.3	-	-	115.3	136.6		
Total absorbed power	kW	5.4	6.1	6.7	7.8	8.9	-	-	9.8	-	-	10.7	12	13.1	-	15.4	17.7	-	19.6	-	-	22.6	27.4		
EER		7.3	6.97	6.72	7.11	6.71	-	-	7.38	-	-	7.28	6.96	6.64	-	7	6.46	-	7.13	-	-	7.39	6.68		
SHR		0.99	1	1	1	1	-	-	1	-	-	0.98	1	1	-	1	1	-	1	-	-	1	1		
<b>R513A - Indoor air 35°C - 30% / Water 15°C - 30°C</b>																									
Cooling capacity	kW	32.7	36.4	39.3	46.8	52.2	-	-	57.6	-	-	63.9	70.6	75.6	-	89.1	98.6	-	108.3	-	-	128.4	152.2		
Total absorbed power	kW	5.5	6.2	6.8	7.9	9.1	-	-	9.9	-	-	10.8	12.2	13.3	-	15.6	17.9	-	19.8	-	-	22.9	27.7		
EER		8.02	7.61	7.34	7.77	7.27	-	-	8.1	-	-	8.01	7.58	7.24	-	7.62	7.07	-	7.8	-	-	8.07	7.33		
SHR		0.98	1	1	1	0.98	-	-	0.99	-	-	1	1	1	-	1	1	-	1	-	-	0.99	1		
Rated air flow	m³/h	8800				11800				15500				19900				25300				32100			
Power supply	V/ph/Hz	400/3+N/50																							
Number of circuits		1	1	1	1	1	1	1	1	1	2	2	2	2	2	2	2	2	2	2	2	2	2		
Lp @ nominal rpm; dist.=2m Q=2	db(A)	61	62	63	66	66	67	67	71	71	71	71	71	71	71	66	66	66	69	69	69	66	66		
Dimensions [LxHxD]	mm	1010x2000x890				1270x2000x890				1760x2000x890				2020x2000x890				2510x2000x890				3160x2000x960			

Also available with 60 Hz power supply. | Height of model Displacement 2250 mm.

Platform **TRF Evolution**

# TRF DX F

## PERIMETER MOUNTED UNITS FOR DATA CENTERS WITH INDIRECT FREE-COOLING

23-150 kW



 LOW GWP REFRIGERANT	 MULTI-PROTOCOL COMMUNICATION INTERFACE	 SCROLL COMPRESSORS	 EC RADIAL FANS
 MODBUS CONTROLLED FANS	 FAST RESTART	 ON-BOARD HUMIDIFIER	 PLATE HEAT EXCHANGER

TRF DX F units are water-condensed perimeter-mounted cabinets that are able to exploit **the effect of indirect water-based Free-Cooling**. The F Series uses Dry Cooler water as both a cooling source for Free-Cooling and a heat exchange fluid for condensing the cooling circuit. TRF DX F units are monobloc units inside which the **entire cooling circuit is concentrated**. Condensation takes place through a brazed-plate heat exchanger made of AISI 304 stainless steel.

- Refrigerant R410A or R513A
- EC Fans
- Scroll on/off compressors
- Advanced control comes as standard
- Temperature control through heating and post-heating systems with electric heating elements (optional)
- Humidity control through dehumidification and humidification (optional)
- Broad choice of accessories, including base modules and plenums for ducting
- Air filter class G3 as standard. Air Filters G4, M5, F7 (optional)
- Double power supply with automatic switch (optional)
- Constant-flow (airflow control) or constant available overpressure ( $\Delta P$  control) ventilation modulation (optional)
- Electronic expansion valves (optional)

### INDIRECT WATER-SIDE FREE-COOLING

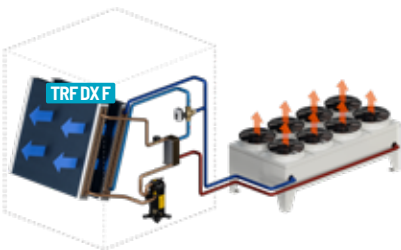

### AIRFLOW CONFIGURATIONS

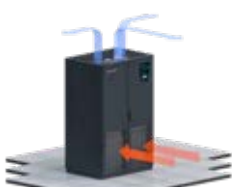

Upflow

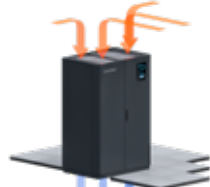

Downflow



Displacement

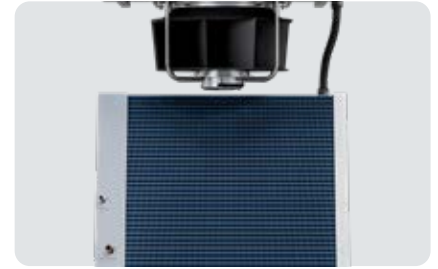

**Easier scheduled maintenance**

The unit has been painstakingly designed to ensure frontal access to components even with the units running. This makes **routine maintenance easier in full compliance with safety standards.**

**Green**

HiRef is constantly committed to the search for refrigerants with ever-lower environmental impact. The use of ASHRAE Class A1 refrigerants, non-toxic and non-flammable, is essential for close control application.

**Efficiency**

The performance, reliability and efficiency of HiRef units are guaranteed **by using the best quality components and by cleverly designed internal and external layouts.**

**Dual circuit**

Double-circuit versions are already available at low power levels. This solution offers **maximum unit redundancy and ensures continuity of service, more precise refrigerating power and less absorption for partial Data Center loads.**

**Safety in the server room**

All models in the TRF DX F range feature heat exchange coils with hydrophilic coating as standard. This special coating - together with an adequate selection of air through-flow speeds - **aids condensate collection during the dehumidification process, preventing any dripping on the inside and outside of the unit.**



**Maximum energy saving**

In periods when the air outside is cooler than the warm air inside the Data Center, the cold water produced by the dry cooler directly feeds the heat exchange coil, which is able to provide a part or all of the required cooling capacity. Before returning to the dry cooler, the water is reused inside the plate exchanger, serving the compressor. The entire process is regulated by a 3-way valve **directly controlled by HiRef software, which maximizes the Free-Cooling effect and checks the cooling circuit.** In this way the work of the compressor is significantly reduced, and shuts down when a state of Free-Cooling is fully reached, **with a significant reduction in the system's PUE.**

TRF DX F	0241	0261	0291	0331	0361	0391	0441	0481	0521	0382	0432	0492	0532	0602	0632	0682	0762	0802	0872	0962	1204	1304											
<b>R410A - Indoor air 30°C - 35% / Water 40°C - 47°C / Free-cooling water 12°C / Glycol 30%</b>																																	
Cooling capacity	kW	26	28.4	31.4	36	38.7	42.7	46.1	51.5	55.9	42.5	47.9	51.8	57.7	62.1	69.1	74.5	81.2	88.3	97.7	103.3	125.2	136.3										
Total absorbed power	kW	7.1	7.5	8.7	9	9.9	11.1	12.4	13.5	14.9	11.1	12.6	14.6	15.4	17.7	18	19.9	22.4	24.4	27.1	29.9	36.3	40.2										
EER		4.38	4.45	4.14	4.83	4.61	4.47	4.23	4.75	4.57	5.06	4.76	4.35	4.55	4.12	4.68	4.47	4.24	4.62	4.48	4.19	4.07	3.93										
SHR		1	1	1	1	1	1	1	1	1	1	1	1	1	1	1	1	1	1	1	1	1	1										
Free-Cooling capacity	kW	24	24.7	25.5	32.4	33.4	34.4	35.3	47.9	49.3	43.8	45.1	49.3	49.3	50.7	57.5	60.8	62.5	77.9	80.1	82.3	109.6	109.6										
SHR Free-Cooling		1	1	1	1	1	1	1	1	1	1	1	1	1	1	1	1	1	1	1	1	1	1										
<b>R410A - Inside air 35°C - 30% / Water 40°C - 47°C / Free-cooling water 17°C / Glycol 30%</b>																																	
Cooling capacity	kW	28.8	31.4	34.5	39.9	42.9	47	50.7	57.2	61.8	47	53.1	57.6	63.9	68.9	76.7	82.6	90.1	98.4	108.1	114.3	137.8	149.9										
Total absorbed power	kW	7.1	7.4	8.7	8.9	9.8	11	12.4	13.4	14.9	11.1	12.6	14.6	15.2	17.6	17.9	19.8	22.4	24.3	27	29.9	36.2	40										
EER		4.85	4.98	4.59	5.41	5.17	4.94	4.67	5.34	5.07	5.61	5.29	4.83	5.1	4.61	5.23	5.01	4.71	5.18	4.97	4.65	4.49	4.34										
SHR		1	1	1	0.98	1	0.99	1	1	1	1	1	1	1	1	1	1	1	1	1	1	1	1										
Free-Cooling capacity	kW	25.6	26.3	26.4	34.5	34.5	35.7	36.6	50.9	50.9	46.9	47.9	50.9	50.9	53.9	61.1	62.7	63	80.4	82.6	85.2	112.7	113.3										
SHR Free-Cooling		1	1	1	1	1	1	1	1	1	1	1	1	1	1	1	1	1	1	1	1	1	1										
<b>R513A - Indoor air 30°C - 35% / Water 40°C - 47°C / Free-Cooling water 12°C / Glycol 30%</b>																																	
Cooling capacity	kW	24	26.3	28	34	38		43.2				49.6	52.8	56.8		66.6	75.1		80.9			95.8	112.7										
Total absorbed power	kW	6.5	7.4	8.2	9.6	11.2		12.3				13.3	15.1	16.5		18.9	22		24.5			28.3	35.1										
EER		4.55	4.25	4.01	4.27	3.97	-	4.56	-	-	-	4.74	4.3	4.16	-	4.31	4.07	-	4.34	-	-	4.51	4.02										
SHR		1	1	1	1	1	-	1	-	-	1	1	1	1	-	1	1	-	1	-	-	0.98	1										
Free-Cooling capacity	kW	24.5	25.2	26	34.1	35.1		47.4				48.9	50.3	51.8		62.1	62.1		77.3			97.3	103.3										
SHR Free-Cooling		1	1	1	1	1		1			1	1	1	1		1	1		1			1	1										
<b>R513A - Indoor air 35°C - 30% / Water 40°C - 47°C / Free-cooling water In 17° / Glycol 30%</b>																																	
Cooling capacity	kW	26.8	29.3	31.3	37.9	42.5		48.7				55.8	59.2	63.4		74.3	83.5		90.9			108	126										
Total absorbed power	kW	6.6	7.5	8.3	9.7	11.3		12.5				13.4	15.3	16.7		19.2	22.2		24.7			28.5	35.4										
EER		5.03	4.68	4.42	4.69	4.41	-	5.06	-	-	-	5.26	4.76	4.58	-	4.75	4.47	-	4.82	-	-	5.03	4.44										
SHR		1	1	1	0.99	1	-	1	-	-	1	1	1	1	-	1	1	-	1	-	-	1	1										
Free-Cooling capacity	kW	25.4	26.1	26.9	35.3	36.2		50.6				52	53.4	54.9		64.1	65.8		80			103.8	109.6										
SHR Free-Cooling		1	1	1	1	1		1			1	1	1	1		1	1		1			1	1										
Rated air flow	m³/h	8000				10800				15500				15000				15500				18600				24500				31800			
Power supply	V/ph/Hz	400/3+N/50																															
Number of circuits		1	1	1	1	1	1	1	1	1	2	2	2	2	2	2	2	2	2	2	2	2	2										
Lp @ nominal rpm; dist.=2m Q=2	db(A)	61	62	62	65	65	65	65	71	71	71	71	71	71	71	71	71	71	71	71	71	71	71										
Dimensions [LxHxD]	mm	1010x2000x890				1270x2000x890				1760x2000x890				1760x2000x890				2020x2000x890				2510x2000x890				3160x2000x960							

Also available with 60 Hz power supply. | Height of model Displacement 2250 mm.

Platform **TRF Evolution**

# TRF DX D/K/Q



## DUAL COOLING PERIMETER MOUNTED UNITS FOR DATA CENTERS

TRF DX D > 23-149 kW

TRF DX K > 23-149 kW

TRF DX Q > 23-149 kW

MULTI-PROTOCOL COMMUNICATION INTERFACE	SCROLL COMPRESSORS	EC RADIAL FANS
MODBUS CONTROLLED FANS	FAST RESTART	ON-BOARD HUMIDIFIER
LOW GWP REFRIGERANT	PLATE HEAT EXCHANGER	

Only Mod. Q and K

TRF DX D units are Dual Cooling units. They combine the traditional evaporative coil of the cooling circuit with **the cooling effect of chilled water** coming from an outdoor unit such as a chiller. The use of a dual source guarantees the **continuity of supply to the system and the best operational solution in all cases, in order to minimize operating costs.**

### WATER CONDENSED WITH DUAL-COOLING

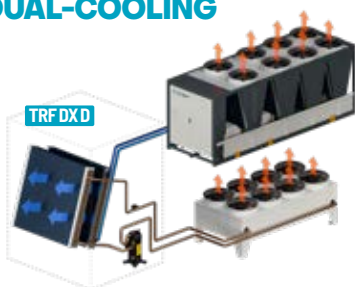

### Dual circuit

Double-circuit versions are already available at low power levels. This solution offers **maximum unit redundancy and ensures continuity of service, more precise refrigerating power and less absorption for partial Data Center loads.**

### AIRFLOW CONFIGURATIONS

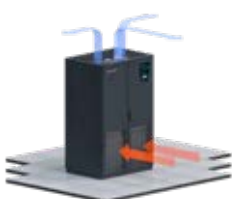

Upflow



Downflow

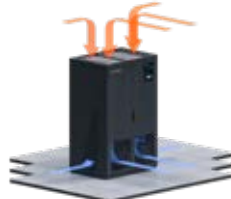

Displacement

- Refrigerant R410A or R513A
- EC Fans
- Scroll on/off compressors
- Advanced control comes as standard
- Temperature control through heating and post-heating systems with electric heating elements (optional)
- Humidity control through dehumidification and humidification (optional)
- Broad choice of accessories, including base modules and plenums for ducting
- Air filter class G3 as standard. Air Filters G4, M5, F7 (optional)
- Double power supply with automatic switch (optional)
- Constant-flow (airflow control) or constant available overpressure ( $\Delta P$  control) ventilation modulation (optional)
- Electronic expansion valves (optional)
- Low temperature kits for optimal operation in the case of installation in particularly cold environments (on request)
- Long distance kits for optimal operation in the case of large distances between indoor and outdoor units (on request, available exclusively for Version D)



**Easier scheduled maintenance**

The unit has been painstakingly designed to ensure frontal access to components. This makes **routine maintenance easier in full compliance with safety standards.**

**Efficiency**

The performance, reliability and efficiency of HiRef units are guaranteed **by using the best quality components and by cleverly designed internal and external layouts.**

**Remote condensers**

All TRF DX D units can be combined with HiRef remote condensers, choosing **from different combinations to meet all system needs.** **Oversize remote condensers** are ideal for warmer environments, where it is necessary to keep the condensing temperature under control, while **the compact condensers** on the other hand are small in terms of both size and consumption. The condensers, used with dual-circuit units, are available with a single cooling circuit for **maximum reliability and redundancy of the system** or with a double cooling circuit, **to reduce installation spaces and costs.**

**Safety in the server room**

All models in the TRF DX D range feature heat exchange coils with hydrophilic coating as standard. This special coating - together with an adequate selection of air through-flow speeds - **aids condensate collection during the dehumidification process, preventing any dripping on the inside and outside of the unit.**

**Green**

HiRef is constantly striving to find refrigerants with an ever decreasing environmental impact. The use of ASHRAE class A1, non-toxic and non-flammable refrigerants is essential in close control applications.

**Maximum flexibility**

The Dual Cooling units combine **the reliability of a dual source with the ease of operation of HiRef cabinets.** The on-board control allows you to select the source according to different logics, at your discretion.



TRF DX D	0241	0261	0291	0331	0361	0391	0441	0481	0521	0382	0432	0492	0532	0602	0632	0682	0762	0802	0872	0962	1204	1304											
<b>R410A - Indoor air 30°C - 35% / Outdoor air 35°C/ Chilled water In 10°C Out 15°C</b>																																	
Cooling capacity	kW	25.8	27.9	31.1	35.5	38.8	42.2	46.3	50.8	55	42.2	46.4	51.4	56.2	62	68	73.6	81.1	87.8	96	103.4	125.8	136										
Total absorbed power	kW	7.2	7.8	8.8	9.3	9.8	11.3	12.4	13.8	15.4	11.2	13.4	14.8	16.1	17.9	18.5	20.4	22.8	24.8	28	30.1	35.8	40.3										
EER		4.24	4.18	4.06	4.58	4.67	4.29	4.27	4.57	4.34	4.94	4.26	4.23	4.17	4.07	4.45	4.29	4.15	4.51	4.23	4.16	4.16	3.91										
SHR		1	1	1	1	1	1	1	1	1	1	1	1	1	1	1	1	1	1	1	1	1	1										
Chilled water cooling capacity	kW	31.4	31.4	31.4	42.3	42.3	42.3	60.8	60.8	60.8	60.8	60.8	60.8	60.8	60.8	72.9	72.9	96.1	96.1	96.1	127.8	127.8	127.8										
SHR chilled water		1	1	1	1	1	1	1	1	1	1	1	1	1	1	1	1	1	1	1	1	1	1										
<b>R410A - Indoor air 35°C - 30% / Outdoor air 35°C/ Chilled water In 15°C Out 20°C</b>																																	
Cooling capacity	kW	28.3	30.3	34.1	39	42.6	46.2	50.5	55.9	60.4	46.2	50.7	56.4	61.4	67.4	74.7	81	88.7	96.5	104.8	112.9	137.5	148.6										
Total absorbed power	kW	7.3	8	8.9	9.4	9.9	11.6	12.5	14	15.6	11.4	13.7	15.3	16.4	18.3	19	20.6	23.2	25.1	28.7	30.6	36.2	40.8										
EER		4.56	4.42	4.39	4.94	5.09	4.59	4.58	4.93	4.7	5.27	4.56	4.49	4.47	4.33	4.76	4.67	4.44	4.88	4.48	4.46	4.47	4.21										
SHR		1	1	1	1	1	1	1	1	1	0.99	1	1	1	1	1	1	1	1	1	1	1	1										
Chilled water cooling capacity	kW	31.6	31.6	31.6	42.7	42.7	42.7	61.2	61.2	61.2	60.7	61.2	61.2	61.2	61.2	73.5	73.5	96.8	96.8	96.8	128.7	128.7	128.7										
SHR chilled water		1	1	1	1	1	1	1	1	1	1	1	1	1	1	1	1	1	1	1	1	1	1										
<b>R513A - Indoor air 30°C - 35% / Outdoor air 35°C/ Chilled water In 10°C Out 15°C</b>																																	
Cooling capacity	kW	24.3	27.2	28.8	34.3	38.8	-	-	44.4	-	-	50.2	57.8	-	66.5	76.2	-	83	-	-	98	115.5	-										
Total absorbed power	kW	6.3	7	7.8	9.4	10.7	-	-	11.8	-	-	13	15	-	18.8	21.1	-	23.5	-	-	27.4	33.7	-										
EER		4.76	4.72	4.35	4.44	4.27	-	-	4.96	-	-	4.93	4.38	-	4.35	4.34	-	4.7	-	-	4.81	4.34	-										
SHR		0.99	1	1	0.99	1	-	-	1	-	-	1	1	-	1	1	-	1	-	-	1	1	-										
Chilled water cooling capacity	kW	32.1	32.1	32.1	43.3	43.3	-	-	63.8	-	-	63.8	63.8	-	76.6	76.6	-	98.3	-	-	127.6	127.6	-										
SHR chilled water		1	1	1	1	1	-	-	1	-	-	1	1	-	1	1	-	1	-	-	1	1	-										
<b>R513A - Indoor air 35°C - 30% / Outdoor air 35°C / Chilled water In 15°C Out 20°C</b>																																	
Cooling capacity	kW	27	29.9	31.8	38.1	43.1	-	-	49.5	-	-	55.8	58.6	63.7	-	73.9	84.3	-	91.8	-	-	108.4	127.4										
Total absorbed power	kW	6.5	7.2	8.1	9.7	11	-	-	12.2	-	-	13.3	15.5	16.4	-	19.3	21.8	-	24	-	-	28.2	34.5										
EER		5.11	5	4.63	4.7	4.59	-	-	5.31	-	-	5.32	4.65	4.69	-	4.68	4.62	-	5.04	-	-	5.12	4.65										
SHR		1	1	1	1	1	-	-	1	-	-	1	1	1	-	1	1	-	1	-	-	0.99	1										
Chilled water cooling capacity	kW	32.4	32.4	32.4	43.7	43.7	-	-	64.3	-	-	64.3	64.3	64.3	-	75.3	75.3	-	99.1	-	-	128.7	128.7										
SHR chilled water		1	1	1	1	1	-	-	1	-	-	1	1	1	-	1	1	-	1	-	-	1	1										
Rated air flow	m³/h	8000				10800				15500				15000				15500				18600				24500				31800			
Power supply	V/ph/Hz	400/3+N/50																															
Number of circuits		1	1	1	1	1	1	1	1	1	2	2	2	2	2	2	2	2	2	2	2	2	2										
Lp @ nominal rpm; dist.=2m Q=2	db(A)	61	62	62	65	65	65	65	71	71	71	71	71	71	71	71	71	71	71	71	71	71	71										
Dimensions [LxHxD]	mm	1010x2000x890				1270x2000x890				1760x2000x890				2020x2000x890				2510x2000x890				3160x2000x960											

Also available with 60 Hz power supply. | Height of model Displacement 2250 mm.

Platform **TRF Evolution**

# TRF DX D/K/Q



**WATER CONDENSED WITH DUAL-COOLING**

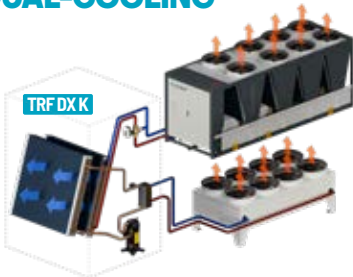

TRF DX K	0241	0261	0291	0331	0361	0391	0441	0481	0521	0382	0432	0492	0532	0602	0632	0682	0762	0802	0872	0962	1204	1304		
<b>R410A - Indoor air 30°C - 35% / Water 40°C - 45°C / Chilled water In 10°C Out 15°C</b>																								
Cooling capacity	kW	26.5	29.1	31.9	36.6	39.3	43.3	47.1	52.6	57.1	43.2	48.7	52.8	58.6	63.1	70.2	76.1	82.9	90.1	99.2	105.5	127.2	138.2	
Total absorbed power	kW	6.8	7.2	8.4	8.6	9.6	10.7	12	13	14.4	10.7	12.2	14.1	14.8	17.1	17.4	19.2	21.6	23.6	26.2	28.9	35	38.8	
EER		4.67	4.78	4.4	5.13	4.89	4.73	4.52	5.09	4.87	5.37	5.07	4.64	4.85	4.38	4.96	4.78	4.52	4.92	4.74	4.47	4.31	4.15	
SHR		1	1	1	0.98	1	0.99	1	1	1	1	1	1	1	1	1	1	1	1	0.99	1	1	0.99	
Chilled water cooling capacity	kW	31.4	31.4	31.4	42.3	42.3	42.3	42.3	60.8	60.8	60.8	60.3	60.8	60.8	60.8	72.9	72.9	72.9	96.1	96.1	96.1	127.8	127.8	
<b>R410A - Indoor air 35°C - 30% / Water 40°C - 45°C / Chilled water In 15°C Out 20°C</b>																								
Cooling capacity	kW	29.4	32.1	35.4	40.8	43.4	47.6	51.5	58.1	63.1	47.9	54	58.8	64.9	70	77.8	83.8	91.3	99.7	109.8	116.1	141.1	152	
Total absorbed power	kW	6.8	7.1	8.3	8.6	9.4	10.6	11.9	12.9	14.3	10.7	12.2	14.1	14.6	17	17.3	19	21.6	23.4	26.1	28.8	34.8	38.6	
EER		5.19	5.35	4.92	5.8	5.48	5.24	4.96	5.67	5.42	5.97	5.62	5.17	5.44	4.9	5.56	5.32	4.99	5.5	5.29	4.94	4.82	4.6	
SHR		1	1	1	1	1	0.98	1	1	1	1	1	1	1	1	1	1	1	1	1	1	1	1	
Chilled water cooling capacity	kW	31.6	31.6	31.6	42.7	42.7	42.7	42.7	61.2	61.2	61.2	60.7	61.2	61.2	61.2	73.5	73.5	73.5	96.8	96.8	96.8	128.7	128.7	
SHR chilled water		1	1	1	1	1	1	1	1	1	1	1	1	1	1	1	1	1	1	1	1	1	1	
<b>R513A - Indoor air 30°C - 35% / Water 40°C - 45°C / Chilled water In 10°C Out 15°C</b>																								
Cooling capacity	kW	24.3	26.6	28.5	34.6	38.7	-	-	44.1	-	-	50.2	53.8	57.8	-	67.4	76	-	82	-	-	97.6	113.9	
Total absorbed power	kW	6.3	7.2	8	9.3	10.8	-	-	12	-	-	12.9	14.7	16.1	-	18.4	21.3	-	23.8	-	-	27.5	34.2	
EER		4.78	4.45	4.23	4.49	4.21	-	-	4.82	-	-	4.97	4.54	4.38	-	4.53	4.27	-	4.55	-	-	4.76	4.2	
SHR		0.99	1	1	1	1	-	-	1	-	-	1	1	1	-	1	1	-	1	-	-	0.99	1	
Chilled water cooling capacity	kW	32.1	32.1	32.1	43.3	43.3	-	-	63.8	-	-	63.8	63.8	63.8	-	76.6	76.6	-	98.3	-	-	127.6	127.6	
SHR chilled water		1	1	1	1	1	-	-	1	-	-	1	1	1	-	1	1	-	1	-	-	1	1	
<b>R513A - Indoor air 35°C - 30% / Water 40°C - 45°C / Chilled water In 15°C Out 20°C</b>																								
Cooling capacity	kW	27.3	29.9	31.6	38.6	43.3	-	-	49.3	-	-	56.4	59.8	64.1	-	75.1	84.4	-	91.8	-	-	109.8	127.5	
Total absorbed power	kW	6.4	7.3	8.1	9.4	11	-	-	12.1	-	-	13.1	14.9	16.2	-	18.6	21.5	-	24	-	-	27.8	34.4	
EER		5.3	4.93	4.63	4.94	4.63	-	-	5.3	-	-	5.51	4.98	4.8	-	4.98	4.69	-	5.04	-	-	5.29	4.65	
SHR		1	1	1	1	1	-	-	0.99	-	-	1	1	1	-	1	1	-	1	-	-	1	1	
Chilled water cooling capacity	kW	32.4	32.4	32.4	43.7	43.7	-	-	64.3	-	-	64.3	64.3	64.3	-	75.3	75.3	-	99.1	-	-	128.7	128.7	
SHR chilled water		1	1	1	1	1	-	-	1	-	-	1	1	1	-	1	1	-	1	-	-	1	1	
Rated air flow	m <sup>3</sup> /h	8000			10800			15500			15000			15500			18600			24500			31800	
Power supply	V/ph/Hz	400/3+N/50																						
Number of circuits		1	1	1	1	1	1	1	1	1	2	2	2	2	2	2	2	2	2	2	2	2	2	
Lp @ nominal rpm; dist.=2m Q=2	db(A)	61	62	62	65	65	65	65	71	71	71	71	71	71	71	71	71	71	69	69	69	66	66	
Dimensions [LxHxD]	mm	1010x2000x890			1270x2000x890			1760x2000x890			2020x2000x890			2510x2000x890			3160x2000x960							

Also available with 60 Hz power supply. | Height of model Displacement 2250 mm.



**MAINS WATER CONDENSED WITH DUAL-COOLING**

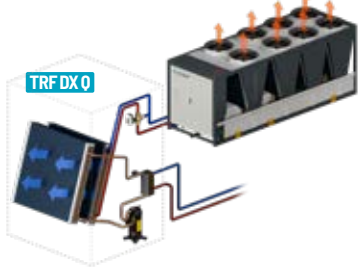

TRF DX Q	0241	0261	0291	0331	0361	0391	0441	0481	0521	0382	0432	0492	0532	0602	0632	0682	0762	0802	0872	0962	1204	1304		
<b>R410A - Indoor air 30°C - 35% / Water 15°C - 30°C / Chilled water In 10°C Out 15°C</b>																								
Cooling capacity	kW	29.7	32.3	35.6	41.2	43.7	48	52.5	59	63.8	49.3	55.2	59.7	65.4	70.5	78.3	83.3	91.3	100.2	110.6	118.1	144	156.8	
Total absorbed power	kW	5.3	5.2	6.1	6.2	6.9	7.7	8.7	9.6	10.8	8.5	9.6	11	10.8	12.7	12.9	14.3	16.2	17.5	19.6	21.8	25.3	28	
EER		7.2	8.01	7.13	8.75	8.11	7.74	7.31	8.56	7.9	8.49	7.88	7.21	8.07	7.02	8.08	7.55	7.05	8.23	7.75	7.15	7.27	6.97	
SHR		1	1	1	1	1	1	0.99	1	1	1	1	1	0.99	1	1	0.96	1	0.98	0.98	1	0.93		
Chilled water cooling capacity	kW	31.4	31.4	31.4	42.3	42.3	42.3	42.3	60.8	60.8	60.3	60.8	60.8	60.8	60.8	72.9	72.9	72.9	96.1	96.1	96.1	127.8	127.8	
SHR chilled water		1	1	1	1	1	1	1	1	1	1	1	1	1	1	1	1	1	1	1	1	1	1	
<b>R410A - Indoor air 35°C - 30% / Water 15°C - 30°C / Chilled water In 15°C Out 20°C</b>																								
Cooling capacity	kW	32.9	35.5	39.1	45.2	48	52.4	56.9	65.1	70	54.4	61.1	66	71.9	77	85.5	91.7	99.8	110	122.4	128	157.1	170.2	
Total absorbed power	kW	5.3	5	6	6	6.7	7.5	8.6	9.3	10.6	8.5	9.6	11	10.4	12.4	12.6	13.9	15.9	16.9	19.1	21.6	24.7	27.4	
EER		7.96	9.26	8.08	10.1	9.28	8.74	8.07	9.86	8.88	9.4	8.72	7.97	9.32	7.9	9.2	8.59	7.89	9.47	8.85	7.87	8.19	7.78	
SHR		1	1	1	1	1	0.99	1	1	1	1	1	1	1	1	1	1	1	1	1	1	1	0.98	
Chilled water cooling capacity	kW	31.6	31.6	31.6	42.7	42.7	42.7	42.7	61.2	61.2	61.2	60.7	61.2	61.2	61.2	73.5	73.5	73.5	96.8	96.8	96.8	128.7	128.7	
SHR chilled water		1	1	1	1	1	1	1	1	1	1	1	1	1	1	1	1	1	1	1	1	1	1	
<b>R513A - Indoor air 30°C - 35% / Water 15°C - 30°C / Chilled water In 10°C Out 15°C</b>																								
Cooling capacity	kW	26.8	29.5	31.3	38.2	42.7	-	-	48.7	-	-	55.3	59	63	-	73.4	83	-	90.5	-	-	108.9	127	
Total absorbed power	kW	5.2	5.9	6.4	7.4	8.6	-	-	9.8	-	-	10.6	11.9	13	-	14.8	17	-	19.2	-	-	22.5	27.3	
EER		6.77	6.38	6.02	6.57	6.15	-	-	7.05	-	-	7.14	6.51	6.19	-	6.49	6.15	-	6.76	-	-	7.05	6.28	
SHR		1	1	1	1	1	-	-	1	-	-	1	1	1	-	1	1	-	1	-	-	1	1	
Chilled water cooling capacity	kW	32.1	32.1	32.1	43.3	43.3	-	-	63.8	-	-	63.8	63.8	63.8	-	76.6	76.6	-	98.3	-	-	127.6	127.6	
SHR chilled water		1	1	1	1	1	-	-	1	-	-	1	1	1	-	1	1	-	1	-	-	1	1	
<b>R513A - Indoor air 35°C - 30% / Water 15°C - 30°C / Chilled water In 15°C Out 20°C</b>																								
Cooling capacity	kW	29.7	32.7	34.8	42.4	47.3	-	-	54.5	-	-	61.6	65.5	69.6	-	81.2	91.3	-	100.4	-	-	120.8	140.7	
Total absorbed power	kW	5.2	5.9	6.5	7.5	8.7	-	-	9.9	-	-	10.7	12.1	13.2	-	15	17.2	-	19.4	-	-	22.7	27.5	
EER		7.4	6.94	6.58	7.18	6.72	-	-	7.75	-	-	7.83	7.09	6.73	-	7.08	6.66	-	7.36	-	-	7.69	6.86	
SHR		0.98	1	1	1	1	-	-	1	-	-	1	1	1	-	1	1	-	1	-	-	0.99	1	
Chilled water cooling capacity	kW	32.4	32.4	32.4	43.7	43.7	-	-	64.3	-	-	64.3	64.3	64.3	-	75.3	75.3	-	99.1	-	-	128.7	128.7	
SHR chilled water		1	1	1	1	1	-	-	1	-	-	1	1	1	-	1	1	-	1	-	-	1	1	
Rated air flow	m <sup>3</sup> /h	8000			10800			15500			15000			15500			18600			24500			31800	
Power supply	V/ph/Hz	400/3+N/50																						
Number of circuits		1	1	1	1	1	1	1	1	1	2	2	2	2	2	2	2	2	2	2	2	2	2	
Lp @ nominal rpm; dist.=2m Q=2	db(A)	61	62	62	65	65	65	65	71	71	71	71	71	71	71	71	71	71	71	71	71	71	71	
Dimensions [LxHxD]	mm	1010x2000x890			1270x2000x890			1760x2000x890			1760x2000x890			2020x2000x890			2510x2000x890			3160x2000x960				

Also available with 60 Hz power supply. | Height of model Displacement 2250 mm.

Platform **TRF Evolution**

# NRG A

## AIR CONDENSED PERIMETER MOUNTED UNITS FOR DATA CENTERS WITH MODULATING COMPRESSORS

9-147 kW



MULTI-PROTOCOL COMMUNICATION INTERFACE	SCROLL COMPRESSORS	EC RADIAL FANS	MODBUS CONTROLLED FANS
FAST RESTART	ON-BOARD HUMIDIFIER	MODULATING HOT GAS POST-HEATING	INVERTER DRIVEN COMPRESSORS

NRG series perimeter-mounted air conditioning units are designed for **high thermal density** IT facilities requiring **accurate hygrothermal parameter control and continuous operation**. The use of inverter-driven compressors, capable of tracking the thermal load with extreme precision, of EC fans (standard), and of electronically controlled lamination valves (standard) also **make it possible to achieve high performance with reduced energy consumption, improving the Data Centre's PUE**. The strength of the new NRG range is **the high cooling density (KW/m<sup>2</sup>)**, obtained thanks to the precise internal design, a frame of just 890 mm in depth, and the careful choice of components.

The NRG A units are air-condensed perimeter-mounted units of the NRG range; they are widely used for the cooling of Data Centers. The air-condensed solution offers a **simple system design**, thanks to the absence of auxiliary circuits and pumps; **the cooling circuit is managed by the cabinet**, and both the indoor unit and the remote condenser are **easy to install**.

### AIR CONDENSED

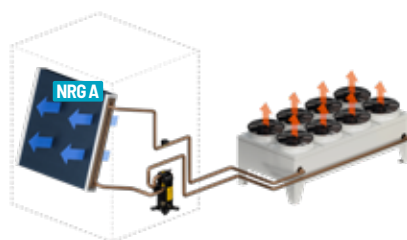

### AIRFLOW CONFIGURATIONS

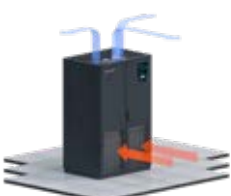

Upflow

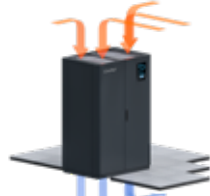

Downflow

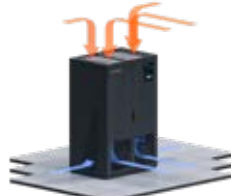

Displacement

- Available refrigerants: R410A or R513A
- EC Fans
- Scroll inverter compressors
- Electronic expansion valves (optional)
- Advanced programmable microprocessor control with LCD display
- Temperature control through heating and post-heating systems with electric heating elements, hot water and hot gas (optional)
- Humidity control through dehumidification and humidification (optional)
- Broad choice of accessories, including base modules and plenums for ducting
- Air filter class G3 as standard. Air Filters G4, M5, F7 (optional)
- Double power supply with automatic switch (optional)
- Constant-flow (airflow control) or constant available overpressure ( $\Delta P$  control) ventilation modulation (optional)
- Low temperature kits for optimal operation in the case of installation in particularly cold environments (on request)
- Long distance kits for optimal operation in the event of large distances between indoor and outdoor units (on request)

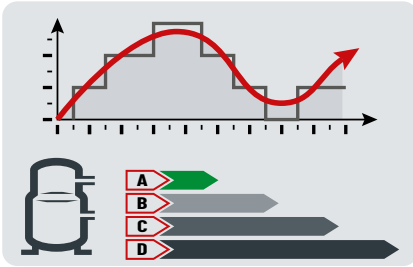

**Power modulation**

The NRG A units adapt quickly to Data Center cooling requests. Thanks to the inverter-controlled compressor, performance can be modulated to **up to 25%** of the rated value, **thus reducing consumption**. This ensures **continuous operation of the unit** even at low loads, without switching cycles on and off.



**Aiming at maximised system efficiency**

Design choices include, in addition to the use of electronically controlled expansion valves, the management of variable-speed Scroll compressors and EC (electronically commutated) fans via Modbus. Thanks to these features it is possible **to acquire, manage and adjust operating parameters and therefore thermohygrometric values in the server room very accurately, with high levels of energy efficiency**.

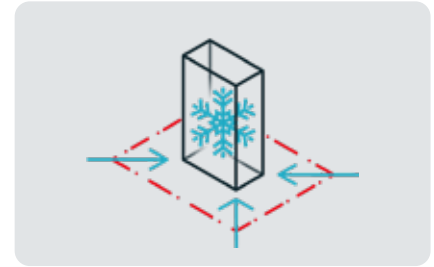

**Maximised power density**

The internal design and the special arrangement of the components of the TRF Evolution platform, used in the NRG units, have been designed to maximise the exchange surface of the evaporating coil. These characteristics, combined with the use of latest-generation electronic switching EC fans with high air flow rate, have allowed **the power density to be increased**. The space available in the server room is made the most of and this makes the NRG A units suitable for applications with **high thermal load density, typical of latest generation Data Centres**.

**Remote condensers**

All units can be combined with HiRef remote condensers, **choosing from different combinations to meet all system needs**. **Upsize remote condensers** are ideal for warmer environments, where it is necessary to keep the condensing temperature under control, while **the compact condensers** on the other hand are small in terms of both size and consumption. The condensers, used with dual-circuit units, are available with a single cooling circuit **for maximum reliability and redundancy** of the system or with a double cooling circuit, **to reduce installation spaces and costs**.

NRG A	0091	0131	0201	0251	0301	0381	0441	0501	0551	0641	0701	0801	0852	0962	1003	1103	1203	1303					
<b>R410A - Indoor air 24°C - 50% / Outdoor air 35°C - 50%</b>																							
Cooling capacity	kW	9.3	12.3	19.8	23.8	31.3	38.1	44	47.7	56.8	58.5	73.8	77.5	81.4	93.3	109.2	127	-	133.9				
Total absorbed power	kW	2.7	3.7	6	6.9	8.9	11.1	13.9	13.9	16.5	17.2	22.8	24	24.7	28	32.1	40.1	-	43.5				
EER		3.74	3.71	4.2	4.19	4.4	4.09	3.63	4.09	3.97	4.1	3.91	4.06	4.31	4.21	4.16	3.71	-	3.67				
SHR		0.89	0.95	1	0.99	1	0.99	0.93	1	0.91	0.99	0.92	0.98	1	0.93	0.87	0.8	-	0.9				
<b>R410A - Indoor air 30°C - 35% / Outdoor air 35°C - 50%</b>																							
Cooling capacity	kW	10	13.9	22.5	27	35.5	43.2	48.7	53.7	62.9	66	82.4	87.6	92	104.1	119	135.7	-	145.7				
Total absorbed power	kW	2.7	3.8	6.1	7.1	9.1	11.3	14.4	14.4	16.8	17.5	23.4	24.8	25.2	28.7	32.4	40.7	-	43.9				
EER		3.94	4.09	4.66	4.64	4.9	4.54	3.85	4.41	4.31	4.51	4.23	4.42	4.77	4.57	4.48	3.89	-	3.94				
SHR		1	1	1	1	1	1	1	1	1	1	1	1	1	1	1	0.98	-	1				
<b>R410A - Indoor air 35°C - 30% / Outdoor air 35°C - 50%</b>																							
Cooling capacity	kW	10.8	15.2	25	29.9	39.2	47.5	53.4	59	69.3	72.7	90	96.1	101.2	114.3	130.1	147.2	-	158.8				
Total absorbed power	kW	2.8	3.9	6.1	7.2	9.2	11.5	14.9	14.8	16.9	17.8	24.1	25.5	25.5	29	33.9	41.3	-	44.6				
EER		4.18	4.35	5.11	5.05	5.34	4.9	4.09	4.71	4.71	4.89	4.46	4.68	5.14	4.93	4.81	4.15	-	4.21				
SHR		1	1	0.99	1	1	1	1	0.99	1	1	1	1	1	0.99	1	1	-	1				
<b>R513A - Indoor air 24°C - 50% / Outdoor air 35°C - 50%</b>																							
Cooling capacity	kW	-	-	-	-	29.7	33.7	42.4	45.5	53.6	57.2	-	61.4	73.2	-	-	-	94.4	112.5				
Total absorbed power	kW	-	-	-	-	11.1	12.5	16.3	17.4	19.9	21.3	-	23.5	26.1	-	-	-	34.3	40.2				
EER		-	-	-	-	3.22	3.19	2.94	3.12	3.14	3.29	-	3.5	3.64	-	-	-	3.45	3.39				
SHR		-	-	-	-	1	1	0.93	1	0.96	1	-	0.99	1	-	-	-	1	0.93				
<b>R513A - Indoor air 30°C - 35% / Outdoor air 35°C - 50%</b>																							
Cooling capacity	kW	-	-	-	-	34	38.5	47.7	51.9	60.9	65.3	-	70.7	83.8	-	-	-	107.6	127				
Total absorbed power	kW	-	-	-	-	11.5	13	16.8	18	20.5	22.2	-	24.4	27	-	-	-	35.6	41.8				
EER		-	-	-	-	3.56	3.48	3.21	3.43	3.44	3.57	-	3.83	3.98	-	-	-	3.75	3.65				
SHR		-	-	-	-	1	1	0.99	0.99	1	1	-	1	1	-	-	-	1	1				
<b>R513A - Indoor air 35°C - 30% / Outdoor air 35°C - 50%</b>																							
Cooling capacity	kW	-	-	-	-	37.9	42.8	52.3	57.4	67.2	72.4	-	78.3	92.8	-	-	-	119.7	140.1				
Total absorbed power	kW	-	-	-	-	11.7	13.4	17.4	18.6	21.3	23	-	25.3	27.9	-	-	-	36.6	43				
EER		-	-	-	-	3.86	3.72	3.38	3.63	3.64	3.8	-	4.04	4.22	-	-	-	4.04	3.89				
SHR		-	-	-	-	1	1	0.99	1	1	1	-	1	1	-	-	-	1	1				
Rated air flow	m³/h	2150	3700	8800				11720				14300		17500	19900	25300			32100				
Power supply	V/ph/Hz	400/3+N/50																					
Number of circuits		1	1	1	1	1	1	1	1	1	1	1	1	2	2	2	2	2	2				
Number of inverter compressors		1	1	1	1	1	1	1	1	1	1	1	1	1	1	1	1	1	1				
Number of on/off compressors		-	-	-	-	-	-	-	-	-	-	-	-	1	1	2	2	2	2				
Lp @ nominal rpm; dist.=2m Q=2	db(A)	50	54	70	70	71	74	74	75	77	77	76	76	76	77	77	77	76	76				
Dimensions [LxHxD]	mm	600 x1875 x600	900 x1875 x600	1010x2000x890				1270x2000x890				1760x2000x890				2020x2000x890				2510x2000x890		3160x2000x960	

Performance data relating to Downflow versions combined with standard HiRef remote condenser. | Also available with 60 Hz power supply. | Model height Displacement 2125 mm for sizes 0091-0131.

Platform **TRF Evolution**

# NRG W/Z

## WATER CONDENSED PERIMETER MOUNTED UNITS FOR DATA CENTERS WITH MODULATING COMPRESSORS

9-112 kW



MULTI-PROTOCOL COMMUNICATION INTERFACE	SCROLL COMPRESSORS	EC RADIAL FANS
MODBUS CONTROLLED FANS	FAST RESTART	ON-BOARD HUMIDIFIER
MODULATING HOT GAS POST-HEATING	INVERTER DRIVEN COMPRESSORS	PLATE HEAT EXCHANGER

The NRG W units are water-condensed perimeter cabinets. The W series uses Dry Cooler water, the Z series on the other hand uses low temperature mains water or groundwater (15°C). The NRG units of these series are monobloc units inside which the **entire cooling circuit is concentrated**, cooling is via a **brazed plate exchanger made from stainless steel AISI 304**.

- Available refrigerants: R410A or R513A
- EC Fans
- Scroll inverter compressors
- Electronic expansion valves (optional)
- Advanced programmable microprocessor control with LCD display
- Temperature control through heating and post-heating systems with electric heating elements, hot water and hot gas (optional)
- Humidity control through dehumidification and humidification (optional)
- Broad choice of accessories, including base modules and plenums for ducting
- Air filter class G3 as standard. Air Filters G4, M5, F7 (optional)
- Double power supply with automatic switch (optional)
- Constant-flow (airflow control) or constant available overpressure (ΔP control) ventilation modulation (optional)
- Low temperature kits for optimal operation in the case of installation in particularly cold environments (on request)

### WATER CONDENSED

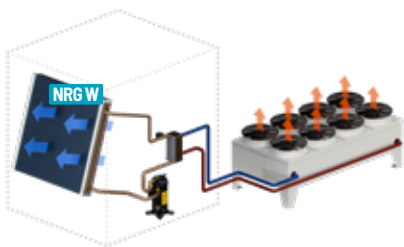

### MAINS WATER CONDENSED

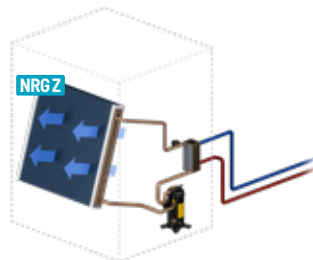

### AIRFLOW CONFIGURATIONS

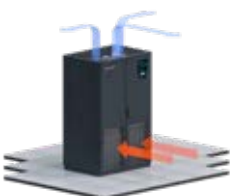

Upflow



Downflow



Displacement

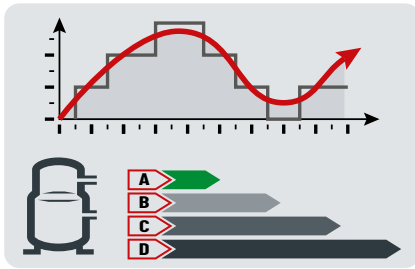

**Power modulation**

The NRG W/Z units adapt quickly to Data Center cooling requests. Thanks to the inverter-controlled compressor, performance can be modulated to **up to 25%** of the rated value, **thus reducing consumption**. This ensures **continuous operation of the unit even at low loads**, without switching cycles on and off.



**Maximised power density**

The internal design and the special arrangement of the components of the TRF Evolution platform, used in the NRG units, have been designed **to maximise the exchange surface of the evaporating coil**. These characteristics, combined with the use of latest-generation electronic switching EC fans with high air flow rate, have allowed the **power density to be increased**. The space available in the server room is made the most of and this makes the NRG W units suitable for applications with **high thermal load density, typical of latest generation Data Centres**.

**Aiming at maximised system efficiency**

Design choices include, in addition to the use of electronically controlled expansion valves, the management of variable-speed Scroll compressors and EC (electronically commutated) fans via Modbus. Thanks to these features it is possible **to acquire, manage and adjust operating parameters and therefore thermo-hygrometric values in the server room very accurately, with high levels of energy efficiency**.

NRG W	0091	0131	0201	0251	0301	0381	0441	0501	0551	0641	0701	0801	0852	0962	1203	1303	
<b>R410A - Indoor air 30°C - 35% / Water 40°C - 45°C</b>																	
Cooling capacity	kW	9.5	13.5	23.6	28.2	36.9	42.4	49.3	52.9	60.5	64.1	79.8	85.6	95	101.5	-	150.2
Total absorbed power	kW	3	4	5.5	6.5	8.4	10.7	13	13.5	16.5	16.9	22.7	23.8	27.5	-	41.5	
EER		3.34	3.77	5.53	5.4	5.62	4.79	4.41	4.69	4.25	4.57	4.25	4.53	5.3	4.69	-	4.35
SHR		0.99	1	1	1	0.99	1	1	0.99	1	0.99	1	1	1	1	-	1
<b>R410A - Indoor air 35°C - 30% / Water 40°C - 45°C</b>																	
Cooling capacity	kW	10.3	14.8	26.4	31.3	41.3	47.1	54.6	58.8	67	71.2	88.1	94.8	105.4	112.1	-	166
Total absorbed power	kW	3.1	4	5.4	6.3	8.2	10.6	13	13.5	16.4	16.8	22.9	24	23.5	27.4	-	41.3
EER		3.57	4.11	6.37	6.13	6.47	5.38	4.87	5.2	4.72	5.1	4.65	4.97	5.96	5.2	-	4.84
SHR		0.99	0.99	1	1	1	1	1	0.99	1	1	0.99	1	1	0.98	-	1
<b>R513A - Indoor air 30°C - 35% / Water 40°C - 45°C</b>																	
Cooling capacity	kW	-	-	-	-	11.1	12.6	16.9	17.6	21.6	22.7	-	23.6	61.8	-	79.6	94.6
Total absorbed power	kW	-	-	-	-	3.8	4.2	5.1	5.9	6.5	7.6	-	9.6	18.2	-	22.7	27.4
EER		-	-	-	-	5.92	5.49	5.25	5.69	5.85	6.22	-	6.47	5.04	-	5.07	4.64
SHR		-	-	-	-	1	0.99	1	1	1	1	-	0.99	1	-	1	1
<b>R513A - Indoor air 35°C - 30% / Water 40°C - 45°C</b>																	
Cooling capacity	kW	-	-	-	-	12.3	14.1	19.3	19.7	24.6	24.9	-	24.9	69.4	-	89.7	106.5
Total absorbed power	kW	-	-	-	-	3.8	4.2	5.1	5.9	6.5	7.6	-	9.6	18.5	-	22.7	27.7
EER		-	-	-	-	6.68	6.18	6.09	6.53	6.66	6.84	-	6.84	5.53	-	5.7	5.13
SHR		-	-	-	-	0.81	0.85	0.99	0.86	0.98	0.73	-	0.53	0.98	-	1	1
<b>NRG Z</b>																	
<b>R410A - Indoor air 30°C - 35% / Water 15°C - 30°C</b>																	
Cooling capacity	kW	10.3	14.9	26	31	40.8	46.6	54.2	58.9	66.9	70.7	88	94.9	105.1	112.4	-	167.3
Total absorbed power	kW	2.3	2.8	4	4.8	6.2	8.1	10.1	10.4	12.8	13.2	18.2	19.3	18.2	21.3	-	31.5
EER		4.8	6.04	9.33	8.8	9.37	7.38	6.55	7.18	6.29	6.85	6.16	6.6	8.55	7.29	-	6.79
SHR		1	0.98	0.99	1	1	0.98	0.98	1	1	0.99	1	1	1	0.98	-	0.97
<b>R410A - Indoor air 35°C - 30% / Water 15°C - 30°C</b>																	
Cooling capacity	kW	11.1	16.5	28.7	34.1	44.9	51.6	59.9	65	73.5	78.2	96.6	104.2	115.6	124	-	182
Total absorbed power	kW	2.3	2.8	3.8	4.5	5.9	7.9	10	10.3	12.7	13	18.3	19.4	17.6	20.9	-	31.3
EER		5.14	6.74	11.22	10.34	11.06	8.46	7.33	8.08	7.03	7.76	6.72	7.22	9.9	8.25	-	7.45
SHR		1	1	0.99	0.99	0.98	1	1	1	1	1	1	0.98	0.99	1	-	1
<b>R513A - Indoor air 30°C - 35% / Water 15°C - 30°C</b>																	
Cooling capacity	kW	-	-	-	-	12.1	13.8	18.6	19.2	23.5	24.7	-	25.9	68.5	-	90	106.1
Total absorbed power	kW	-	-	-	-	2.9	3.2	3.7	4.8	5.4	6.2	-	8.3	15.4	-	16.8	22.4
EER		-	-	-	-	9.83	9.04	9.39	9.84	9.02	9.85	-	10.36	7.08	-	9.05	6.84
SHR		-	-	-	-	0.99	0.99	1	0.98	1	1	-	1	1	-	1	1
<b>R513A - Indoor air 35°C - 30% / Water 15°C - 30°C</b>																	
Cooling capacity	kW	-	-	-	-	13.6	15.5	20.9	21.7	26.4	27.7	-	28.3	76.5	-	100.4	118
Total absorbed power	kW	-	-	-	-	2.9	3.2	3.6	4.6	5.4	6.2	-	8.2	15.7	-	16.4	22.8
EER		-	-	-	-	11.6	10.27	11.26	12.1	10.18	11.18	-	11.44	7.66	-	10.55	7.42
SHR		-	-	-	-	1	1	0.99	1	0.98	0.99	-	0.8	0.99	-	1	0.99
Rated air flow	m³/h	2150	3700	8800		11720		14300		17500	19900	23700	25300		32100		
Power supply	V/ph/Hz	400/3+N/50															
Number of circuits		1	1	1	1	1	1	1	1	1	1	1	1	2	2	2	2
Number of inverter compressors		1	1	1	1	1	1	1	1	1	1	1	1	1	1	1	1
Number of on/off compressors																	
Lp @ nominal rpm; dist.=2m 0=2	db(A)	50	54	70	70	71	74	74	75	77	77	76	76	76	76	76	76
Dimensions [LxHxD]	mm	600 x1875 x600	900 x1875 x600	1010x2000x890		1270x2000x890		1760x2000x890		2020x2000x890		2510x2000x890		3160x2000x960			

Performance data relating to Downflow versions. | Also available with 60 Hz power supply. | Model height Displacement 2125 mm for sizes 0091-0131.

Platform **TRF Evolution**

# NRG F

## PERIMETER MOUNTED UNITS FOR DATA CENTERS WITH MODULATING COMPRESSORS WITH INDIRECT FREE-COOLING

11-99 kW



MULTI-PROTOCOL COMMUNICATION INTERFACE	SCROLL COMPRESSORS	EC RADIAL FANS	MODBUS CONTROLLED FANS
FAST RESTART	ON-BOARD HUMIDIFIER	INVERTER DRIVEN COMPRESSORS	PLATE HEAT EXCHANGER

NRG F units are water-condensed perimeter-mounted cabinets that are able to exploit the **effect of indirect water-based Free-Cooling**. The F Series uses Dry Cooler water as both a cooling source for free-cooling and a heat exchange fluid for condensing the cooling circuit. NRG F units are "monobloc" units inside which the **entire cooling circuit** is concentrated. Cooling is via a **braced plate exchanger made of stainless steel AISI 304**.

### Maximum energy saving

In periods when the air outside is cooler than the warm air inside the Data Center, the cold water produced by the dry cooler directly feeds the heat exchange coil, which is able to provide a part or all of the required cooling capacity. Before returning to the dry cooler, the water is reused inside the plate exchanger, serving the compressor. The entire process is regulated by a 3-way valve **directly controlled by HiRef software, which maximizes the Free-Cooling effect and checks the cooling circuit**. In this way the work of the compressor is significantly reduced, and shuts down when a state of Free-Cooling is fully reached, **with a significant reduction in the system's PUE**.

### INDIRECT WATER-SIDE FREE-COOLING

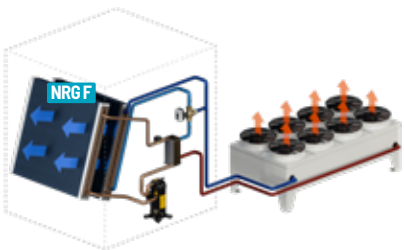

### AIRFLOW CONFIGURATIONS

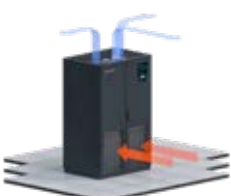

Upflow

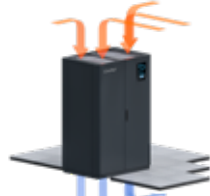

Downflow

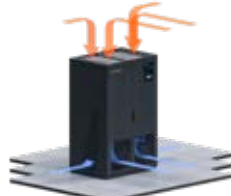

Displacement

- Available refrigerants: R410A or R513A
- EC Fans
- Scroll inverter compressors
- Electronic expansion valves (optional)
- Advanced programmable microprocessor control with LCD display
- Temperature control through heating and post-heating systems with electric heating elements (optional)
- Humidity control through dehumidification and humidification (optional)
- Broad choice of accessories, including base modules and plenums for ducting
- Air filter class G3 as standard. Air Filters G4, M5, F7 (optional)
- Double power supply with automatic switch (optional)
- Constant-flow (airflow control) or constant available overpressure ( $\Delta P$  control) ventilation modulation (optional)

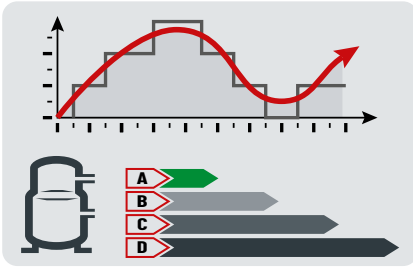

**Power modulation**

NRG F units adapt quickly to Data Center cooling requests. Thanks to the inverter-controlled compressor, performance can be modulated to **up to 25%** of the rated value, thus reducing consumption. This ensures **continuous operation of the unit even at low loads**, without switching cycles on and off.



**Aiming at maximised system efficiency**

Design choices include, in addition to the use of electronically controlled expansion valves, the management of variable-speed Scroll compressors and EC (electronically commutated) fans via Modbus. Thanks to these features it is possible **to acquire, manage and adjust operating parameters and therefore thermo-hygrometric values in the server room very accurately, with high levels of energy efficiency.**

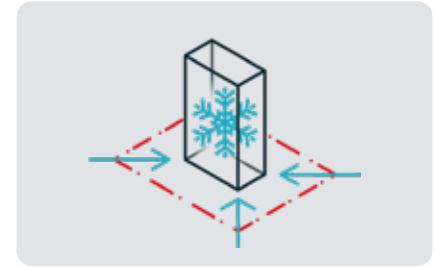

**Maximised power density**

The internal design and the special arrangement of the components of the TRF Evolution platform, used in the NRG units, have been designed **to maximise the exchange surface of the evaporating coil.** These characteristics, combined with the use of latest-generation electronic switching EC fans with high air flow rate, have allowed the **power density to be increased.** The space available in the server room is made the most of and this makes the NRG F units suitable for applications with **high thermal load density**, typical of latest generation Data Centers.

NRG F		0131	0201	0251	0301	0381	0441	0501	0551	0641	0701	0801	0852	0962	1203	1303
<b>R410A - Indoor air 24°C - 50% / Water 40°C - 45°C / Free-cooling water 7°C / Glycol 30%</b>																
Cooling capacity	kW	11.4	19.3	22.9	29.3	33.7	39.9	43.7	51	51.8	64.2	69.7	76.2	82.7	-	132.5
Total absorbed power	kW	4	5.6	6.5	8.3	10.6	12.7	13.5	16.6	16.8	21.2	23.3	22.9	26.4	-	42.1
EER		3.18	4.35	4.25	4.33	3.75	3.58	3.88	3.57	3.67	3.48	3.74	4.18	3.8	-	3.77
SHR		0.93	1	1	1	0.91	0.85	0.96	0.86	0.95	0.83	0.96	0.94	0.87	-	0.84
Free-Cooling capacity	kW	8.8	22.5	24.6	33.3	37.8	40.8	48	52	56.4	65.8	80.4	80.4	86.8	-	126.1
SHR Free-Cooling		0.93	1	0.9	0.9	0.84	0.81	0.87	0.83	0.87	0.8	0.85	0.85	0.81	-	0.8
<b>R410A - Indoor air 30°C - 35% / Water 40°C - 47°C / Free-cooling water 12°C / Glycol 30%</b>																
Cooling capacity	kW	12.5	21.9	25.7	32.9	37.3	43.1	48.7	55.5	57.8	68.9	77.7	84.2	89.5	-	140.8
Total absorbed power	kW	4.2	5.7	6.6	8.5	10.8	13.1	14	17	17.2	21.9	24	23.5	27.2	-	43.3
EER		3.36	4.83	4.67	4.73	4.04	3.74	4.17	3.77	3.98	3.6	4.01	4.47	3.97	-	3.88
SHR		1	1	0.99	0.98	0.99	1	1	1	1	0.99	1	1	1	-	1
Free-Cooling capacity	kW	8.5	22.6	24	31.5	34.4	35.3	45.5	48	53.4	57.9	73.2	75.2	77.3	-	109.2
SHR Free-Cooling		1	1	1	1	1	1	1	1	1	1	1	1	1	-	1
<b>R410A - Inside air 35°C - 30% / Water 40°C - 47°C / Free-cooling water 17°C / Glycol 30%</b>																
Cooling capacity	kW	13.9	24.3	28.6	36.6	41.6	47.6	54	61.2	63.6	75.9	85.4	93.2	99.2	-	155
Total absorbed power	kW	4.2	5.6	6.6	8.4	10.8	13.2	14	17	17.2	22.1	24.2	23.4	27.2	-	43.2
EER		3.69	5.47	5.26	5.33	4.52	4.1	4.59	4.15	4.38	3.92	4.36	4.98	4.4	-	4.29
SHR		1	1	1	0.99	1	1	0.99	0.99	0.99	0.99	0.98	0.99	1	-	1
Free-Cooling capacity	kW	9	23.5	24.9	33.6	35.5	36.6	48.2	49.7	56.6	58.4	77.5	77.5	80	-	113.2
SHR Free-Cooling		1	1	1	1	1	1	1	1	1	1	1	1	1	-	1
<b>R513A - Indoor air 30°C - 35% / Water 40°C - 47°C / Free-Cooling water 12°C / Glycol 30%</b>																
Cooling capacity	kW	-	-	-	10.6	12	15.7	17	20.6	20.8	-	21.8	55.6	-	74	87.8
Total absorbed power	kW	-	-	-	3.6	4	5	6.1	6.7	7.3	-	9.6	18.2	-	23.4	28
EER		-	-	-	5.34	4.95	4.6	5.16	5.31	5.43	-	5.7	4.47	-	4.51	4.19
SHR		-	-	-	1	1	0.99	0.99	1	1	-	1	1	-	1	1
Free-Cooling capacity	kW	-	-	-	17.5	18.4	22.7	25.7	29.9	30.1	-	34.2	64.9	-	84.2	89.9
SHR Free-Cooling		-	-	-	1	1	1	1	1	1	-	1	1	-	1	1
<b>R513A - Indoor air 35°C - 30% / Water 40°C - 47°C / Free-cooling water In 17° / Glycol 30%</b>																
Cooling capacity	kW	-	-	-	12	13.7	17.9	19.3	23.4	23.8	-	24.3	62.5	-	83.4	98.4
Total absorbed power	kW	-	-	-	3.6	4	5	6.1	6.7	7.3	-	9.6	18.5	-	23.5	28.3
EER		-	-	-	6.19	5.67	5.27	5.97	6.01	6.21	-	6.35	4.91	-	5.06	4.63
SHR		-	-	-	0.95	0.98	1	0.96	0.99	1	-	0.85	1	-	1	1
Free-Cooling capacity	kW	-	-	-	18.6	20.4	24.2	29.3	34.7	32	-	35.7	67.7	-	90.6	96.1
SHR Free-Cooling		-	-	-	1	1	1	1	1	1	-	1	1	-	1	1
Rated air flow	m³/h	3700	8000			10800			14300		16800		23000			31800
Power supply	V/ph/Hz								400/3+N/50							
Number of circuits		1	1	1	1	1	1	1	1	1	1	1	2	2	2	2
Number of inverter compressors		1	1	1	1	1	1	1	1	1	1	1	1	1	1	1
Number of on/off compressors		-	-	-	-	-	-	-	-	-	-	-	1	1	2	2
Lp @ nominal rpm; dist.=2m Q=2	db(A)	54	70	70	70	74	74	75	77	77	75	76	75	75	76	76
Dimensions [LxHxD]	mm	900 x1875 x600	1010x2000x890			1270x2000x890			1760x2000x890		2020x2000x890		2510x2000x890			3160x2000x960

Performance data relating to Downflow versions. | Also available with 60 Hz power supply. | Model height Displacement 2125 mm for size 0131.

Platform **TRF Evolution**

# NRG D/K/Q

## DUAL COOLING PERIMETER MOUNTED UNITS FOR DATA CENTERS WITH MODULATING COMPRESSORS

NRG D > 12-99 kW

NRG K > 11-101 kW

NRG Q > 13-110 kW



MULTI-PROTOCOL COMMUNICATION INTERFACE	SCROLL COMPRESSORS	EC RADIAL FANS	MODBUS CONTROLLED FANS
FAST RESTART	ON-BOARD HUMIDIFIER	INVERTER DRIVEN COMPRESSORS	

NRG D/K/Q units are Dual Cooling units. They combine the traditional evaporative coil of the cooling circuit with **the cooling effect of chilled water**, coming from an outdoor unit such as a chiller. The use of a dual source guarantees the **continuity of supply to the system** and **the best operational solution in all cases**.



**Maximum flexibility**

The Dual Cooling units combine **the reliability of a dual source with the ease of operation of HiRef cabinets**. The on-board control allows you to select the source according to different logics, at your discretion.

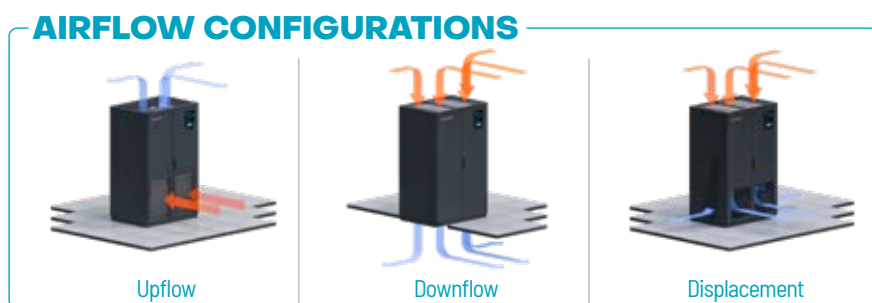

- Refrigerant R410A
- EC Fans
- Scroll inverter compressors
- Electronic expansion valves (optional)
- Advanced programmable microprocessor control with LCD display
- Temperature control through heating and post-heating systems with electric heating elements (optional)
- Humidity control through dehumidification and humidification (optional)
- Broad choice of accessories, including base modules and plenums for ducting
- Air filter class G3 as standard. Air Filters G4, M5, F7 (optional)
- Double power supply with automatic switch (optional)
- Constant-flow (airflow control) or constant available overpressure ( $\Delta P$  control) ventilation modulation (optional)
- Long distance kits for optimal operation in the case of large distances between indoor and outdoor units (on request, available exclusively for Version D)
- Low temperature kits for optimal operation in the case of installation in particularly cold environments (on request)

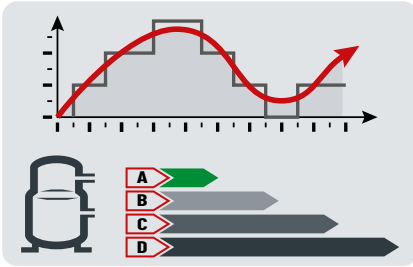

**Power modulation**

The NRG D/K/Q units adapt quickly to Data Center cooling requests. Thanks to the inverter-controlled compressor, performance can be modulated to **upto 25%** of the rated value, **thus reducing consumption**. This ensures **continuous operation of the unit even at low loads**, without switching cycles on and off.



**Remote condensers**

All NRG D/K/Q units can be combined with HiRef remote condensers, choosing from **different combinations to meet all system needs**. **Oversize remote condensers** are ideal for warmer environments, where it is necessary to keep the condensing temperature under control, while the **compact condensers** on the other hand are small in terms of both size and consumption. The condensers, used with dual-circuit units, are available with a single cooling circuit **for maximum reliability and redundancy of the system** or with a double cooling circuit, **to reduce installation spaces and costs**.



**Aiming at maximised system efficiency**

Design choices include, in addition to the use of electronically controlled expansion valves, the management of variable-speed Scroll compressors and EC (electronically commutated) fans via Modbus. Thanks to these features it is possible **to acquire, manage and adjust operating parameters and therefore thermo-hygrometric values in the server room very accurately, with high levels of energy efficiency**.

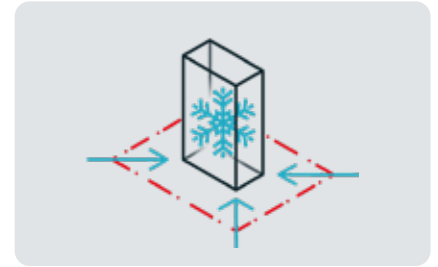

**Maximised power density**

The internal design and the special arrangement of the components of the TRF Evolution platform, used in the NRG units, have been designed **to maximise the exchange surface of the evaporating coil**. These characteristics, combined with the use of latest-generation electronic switching EC fans with high air flow rate, have allowed the **power density to be increased**. The space available in the server room is made the most of and this makes the NRG D/K/Q units suitable for applications with **high thermal load density**, typical of latest generation Data Centres.



NRG D		0131	0201	0251	0301	0381	0441	0501	0551	0641	0701	0801	0852	0962	1303
<b>R410A - Indoor air 24°C - 50% / Outdoor air 35°C - 50% / Chilled water 7°C - 12°C</b>															
Cooling capacity	kW	11.7	18.8	22.4	28.8	33.4	38.5	43	51.6	51.7	64.4	69.4	73.6	82.8	130.4
Total absorbed power	kW	3.7	5.8	6.8	8.6	10.7	13.4	13.8	16.3	16.8	21.1	23.4	24	26.4	43.1
EER		3.57	4	3.96	4.11	3.64	3.25	3.73	3.66	3.66	3.51	3.71	3.81	3.81	3.61
SHR		0.9	1	1	1	0.93	0.86	0.96	0.88	0.95	0.84	0.96	0.93	0.88	0.85
Chilled water cooling capacity	kW	8.2	29.1	29.1	40.8	40.8	40.8	56	56	65.8	65.8	90	90	90	121.4
SHR chilled water		1	0.82	0.82	0.81	0.81	0.81	0.8	0.8	0.8	0.8	0.8	0.8	0.8	0.81
<b>R410A - Indoor air 30°C - 35% / Outdoor air 35°C - 50% / Chilled water 10°C - 15°C</b>															
Cooling capacity	kW	13	21.4	25.3	32.5	37.2	42	48.4	56.2	57.8	69.7	77.5	82.3	90.1	140.3
Total absorbed power	kW	3.8	5.9	6.9	8.7	11	13.7	14.2	16.7	17.1	21.6	24.1	24.5	26.8	43.5
EER		3.89	4.48	4.4	4.54	3.96	3.47	4.06	3.91	4.01	3.69	3.99	4.14	4.07	3.85
SHR		1	1	1	0.99	1	1	1	1	1	1	1	0.99	1	1
Chilled water cooling capacity	kW	10.5	31.4	31.4	42.3	42.3	42.3	57.5	57.5	67.5	67.5	92.5	92.5	92.5	127.6
SHR chilled water		1	1	1	1	1	1	1	1	1	1	1	1	1	1
<b>R410A - Indoor air 35°C - 30% / Outdoor air 35°C - 50% / Chilled water 15°C - 20°C</b>															
Cooling capacity	kW	14.4	23.5	27.9	36	41	46.1	52.9	61.7	63.7	76.1	85	90.4	98.9	153.3
Total absorbed power	kW	3.9	6	7	8.8	11.1	14.1	14.6	16.8	17.3	22	24.7	25	27.3	44.2
EER		4.2	4.86	4.78	4.97	4.31	3.69	4.3	4.24	4.35	3.95	4.25	4.44	4.36	4.12
SHR		1	0.99	1	1	1	1	0.99	1	1	1	1	1	1	1
Chilled water cooling capacity	kW	10.7	31.6	31.6	42.7	42.7	42.7	57.9	57.9	68	68	93.1	93.1	93.1	128.7
SHR chilled water		1	1	1	1	1	1	1	1	1	1	1	1	1	1
Rated air flow	m³/h	3700	8000		10800		14300		16800		23000				31800
Power supply	V/ph/Hz						400/3+N/50								
Number of circuits		1	1	1	1	1	1	1	1	1	1	1	2	2	2
Number of inverter compressors		1	1	1	1	1	1	1	1	1	1	1	1	1	1
Number of on/off compressors		-	-	-	-	-	-	-	-	-	-	-	1	1	2
Lp @ nominal rpm; dist.=2m Q=2	db(A)	54	70	70	70	74	74	75	77	77	75	76	75	75	76
Dimensions [LxHxD]	mm	900 x1875 x600	1010x2000x890		1270x2000x890		1760x2000x890		2020x2000x890		2510x2000x890				3160 x2000 x960

Performance data relating to Downflow versions combined with standard HiRef remote condenser. | Also available with 60 Hz power supply. | Model height Displacement 2125 mm for size 0131.

Platform **TRF Evolution**

# NRG D/K/Q



**WATER CONDENSED WITH DUAL-COOLING**

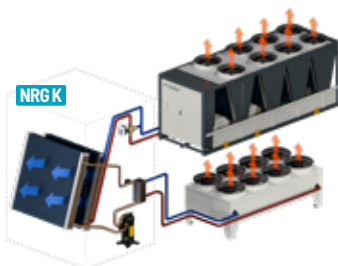

NRG K		0131	0201	0251	0301	0381	0441	0501	0551	0641	0701	0801	0852	0962	1303	
<b>R410A - Indoor air 24°C - 50% / Water 40°C - 45°C / Chilled water In 7°C Out 12°C</b>																
Cooling capacity	kW	11.4	19.3	23	29.4	33.8	40.1	43.6	51.2	52	64.5	69.7	76	83.1	133	
Total absorbed power	kW	4	5.5	6.5	8.3	10.5	12.6	13.4	16.5	16.7	21.1	23.1	22.8	26.3	41.7	
EER		3.23	4.37	4.3	4.36	3.79	3.63	3.91	3.61	3.71	3.51	3.77	4.2	3.85	3.83	
SHR		0.91	1	1	1	0.91	0.85	0.93	0.87	0.96	0.84	0.94	0.91	0.88	0.82	
Chilled water cooling capacity	kW	8.2	29.1	29.1	40.8	40.8	40.8	56	56	65.8	65.8	90	90	90	121.4	
SHR chilled water		1	0.82	0.82	0.81	0.81	0.81	0.8	0.8	0.8	0.8	0.8	0.8	0.8	0.81	
<b>R410A - Indoor air 30°C - 35% / Water 40°C - 45°C / Chilled water In 10°C Out 15°C</b>																
Cooling capacity	kW	12.7	22.2	26.1	33.4	38.1	43.7	49.4	56.3	58.6	69.9	78.8	86	91	143.7	
Total absorbed power	kW	4	5.5	6.4	8.2	10.5	12.7	13.5	16.5	16.7	21.2	23.4	22.7	26.3	41.6	
EER		3.57	5.13	4.94	5.01	4.28	3.93	4.39	3.96	4.18	3.77	4.21	4.76	4.2	4.16	
SHR		1	1	0.99	0.99	1	1	0.99	1	1	0.99	1	1	1	0.99	
Chilled water cooling capacity	kW	10.5	31.4	31.4	42.3	42.3	42.3	57.5	57.5	67.5	67.5	92.5	92.5	92.5	127.6	
SHR chilled water		1	1	1	1	1	1	1	1	1	1	1	1	1	1	
<b>R410A - Indoor air 35°C - 30% / Water 40°C - 45°C / Chilled water In 15°C Out 20°C</b>																
Cooling capacity	kW	14.1	24.7	29.1	37.2	42.1	48.2	55.1	62.4	64.5	77	87	94.4	100.8	158.2	
Total absorbed power	kW	4	5.4	6.3	8.1	10.4	12.8	13.6	16.5	16.7	21.4	23.6	22.6	26.3	41.5	
EER		3.93	5.84	5.59	5.68	4.76	4.32	4.88	4.39	4.6	4.12	4.6	5.26	4.66	4.6	
SHR		1	1	1	1	1	1	1	1	1	0.99	0.99	1	0.98	1	
Chilled water cooling capacity	kW	10.7	31.6	31.6	42.7	42.7	42.7	57.9	57.9	68	68	93.1	93.1	93.1	128.7	
SHR chilled water		1	1	1	1	1	1	1	1	1	1	1	1	1	1	
Rated air flow	m <sup>3</sup> /h	3700	8000			10800		14300			16800		23000		31800	
Power supply	V/ph/Hz	400/3+N/50														
Number of circuits		1	1	1	1	1	1	1	1	1	1	1	2	2	2	
Number of inverter compressors		1	1	1	1	1	1	1	1	1	1	1	1	1	1	
Number of on/off compressors		-	-	-	-	-	-	-	-	-	-	-	1	1	2	
Lp @ nominal rpm; dist.=2m Q=2	db(A)	54	70	70	70	74	74	75	77	77	75	76	75	75	76	
Dimensions [LxHxD]	mm	900 x1875 x600	1010x2000x890			1270x2000x890		1760x2000x890			2020x2000x890		2510x2000x890		3160 x2000 x960	

Performance data relating to Downflow versions. | Also available with 60 Hz power supply. | Model height Displacement 2125 mm for size 0131.

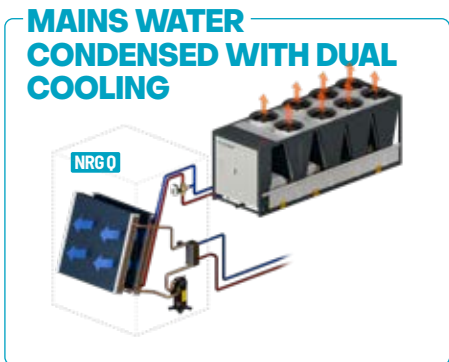

NRG 0	0131	0201	0251	0301	0381	0441	0501	0551	0641	0701	0801	0852	0962	1303	
<b>R410A - Indoor air 24°C - 50% / Water 15°C - 30°C / Chilled water In 7°C Out 12°C</b>															
Cooling capacity	kW	12.9	21.4	25.6	32.4	37.9	45.3	49.6	57.6	57.8	71.5	77.8	86.2	94.3	151.2
Total absorbed power	kW	2.9	4.2	5	6.4	8.2	9.9	10.6	13	13.3	16.8	18.8	17.7	20.4	32
EER		5.15	6.92	6.68	6.73	5.76	5.45	5.98	5.35	5.47	5.09	5.5	6.62	5.98	6.06
SHR		0.86	0.99	0.94	0.99	0.87	0.82	0.89	0.83	0.89	0.79	0.87	0.88	0.83	0.8
Chilled water cooling capacity	kW	8.2	29.1	29.1	40.8	40.8	40.8	56	56	65.8	65.8	90	90	90	121.4
SHR chilled water		1	0.82	0.82	0.81	0.81	0.81	0.8	0.8	0.8	0.8	0.8	0.8	0.8	0.81
<b>R410A - Indoor air 30°C - 35% / Water 15°C - 30°C / Chilled water In 10°C Out 15°C</b>															
Cooling capacity	kW	13.9	24.5	28.7	36.7	41.7	48.2	54.9	61.8	64.3	76.6	86.5	94.1	101.1	160.6
Total absorbed power	kW	2.9	4	4.8	6.2	8.1	9.9	10.5	13	13.2	16.8	18.9	17.4	20.3	31.8
EER		5.62	8.44	7.86	7.96	6.43	5.8	6.65	5.76	6.14	5.42	6.07	7.37	6.45	6.48
SHR		0.98	1	1	1	1	0.97	1	0.99	1	0.96	1	0.98	1	0.94
Chilled water cooling capacity	kW	10.5	31.4	31.4	42.3	42.3	42.3	57.5	57.5	67.5	67.5	92.5	92.5	92.5	127.6
SHR chilled water		1	1	1	1	1	1	1	1	1	1	1	1	1	1
<b>R410A - Indoor air 35°C - 30% / Water 15°C - 30°C / Chilled water In 15°C Out 20°C</b>															
Cooling capacity	kW	15.4	26.9	31.7	40.5	45.7	52.7	60.2	67.7	70.7	83.4	94.9	103.8	110.3	174
Total absorbed power	kW	2.9	3.8	4.6	6	7.9	9.9	10.4	12.9	13	16.9	19	17	20.1	31.7
EER		6.27	9.95	9.14	9.25	7.19	6.37	7.37	6.39	6.85	5.86	6.6	8.42	7.14	7.06
SHR		1	0.99	1	1	0.99	1	0.99	0.99	1	1	0.99	1	1	0.98
Chilled water cooling capacity	kW	10.7	31.6	31.6	42.7	42.7	42.7	57.9	57.9	68	68	93.1	93.1	93.1	128.7
SHR chilled water		1	1	1	1	1	1	1	1	1	1	1	1	1	1
Rated air flow	m <sup>3</sup> /h	3700	8000		10800			14300		16800		23000		31800	
Power supply	V/ph/Hz	400/3+N/50													
Number of circuits		1	1	1	1	1	1	1	1	1	1	1	2	2	2
Number of inverter compressors		1	1	1	1	1	1	1	1	1	1	1	1	1	1
Number of on/off compressors		-	-	-	-	-	-	-	-	-	-	-	1	1	2
Lp @ nominal rpm; dist.=2m Q=2	db(A)	54	70	70	70	74	74	74	75	77	77	75	76	75	76
Dimensions [LxHxD]	mm	900 x1875 x600	1010x2000x890		1270x2000x890			1760x2000x890		2020x2000x890		2510x2000x890		3160 x2000 x960	

Performance data relating to Downflow versions. | Also available with 60 Hz power supply. | Model height Displacement 2125 mm for size 0131.

# JREF CW

## Radial



### CHILLED WATER PERIMETER MOUNTED UNITS FOR DATA CENTERS

15-33 kW

MULTI-PROTOCOL COMMUNICATION INTERFACE	EC RADIAL FANS	MODBUS CONTROLLED FANS
FAST RESTART	ON-BOARD HUMIDIFIER	DOUBLE CIRCUIT

The JREF CW Radial series perimeter mounted units are chilled water units with EC radial fans for small-sized premises such as server rooms and labs or for applications where **accurate control of thermo-hygrometric parameters and round-the-clock operation are required**. In-depth CFD (computational fluid dynamics) analysis has allowed for the meticulous design of every last constructive detail to **minimise air pressure drops and, therefore, fan power consumption**. Air through-flow sections have been expanded to make **installation and maintenance operations faster and easier**.

- Temperature control through heating and post-heating systems using electric heating elements, additional hot water coil, or both (optional)
- Humidity control through dehumidification and humidification (optional)
- Fan speed modulation based on thermal load (constant  $\Delta T$ )
- Broad choice of accessories, including base modules and plenums for ducting
- Air filter class G3 as standard. Air Filters G4, M5, F7 (optional)
- Double power supply with automatic switch (optional)
- Constant-flow (airflow control) or constant available overpressure ( $\Delta P$  control) ventilation modulation (optional)
- Instant reading of water flow rate, water inlet and outlet temperatures, or supplied cooling capacity (optional)

#### CHILLED WATER

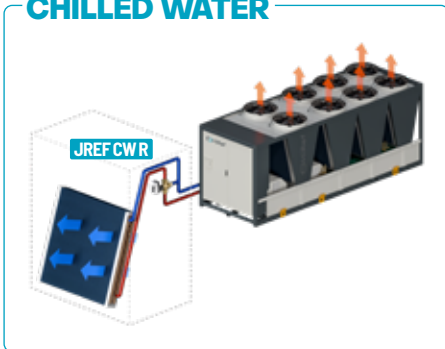

#### AIRFLOW CONFIGURATIONS

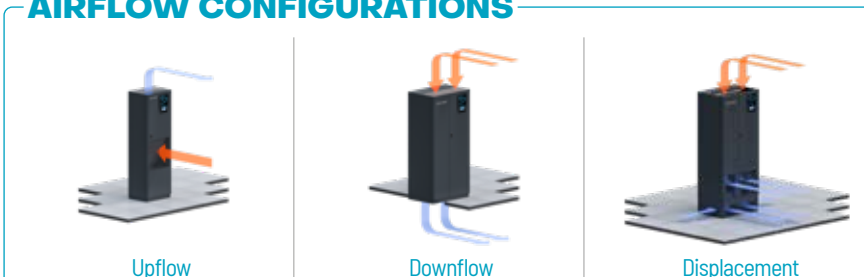

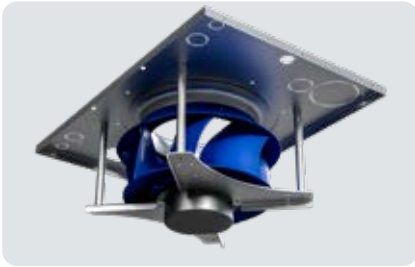

**Ventilation EC**

EC PLUG fans, standard throughout the range, are adjustable using different logics: flow rate, overpressure, constant ΔP and ΔT. Their accurate adjustment allows an efficient use of power for ventilation and **a consequent reduction of the system's PUE**. Extended range speed adjustment is carried out via Modbus protocol. The "emergency speed" function allows for fan operation **even in the event of microprocessor malfunctions**.



**Accurate regulation with multiple types of valves**

All units in the JREF CW Radial range have as standard regulating valves fitted with 0-10V servo motor, selectable in 2-way execution, with variable or 3-way flow system or with servo motor with spring return. On request, pressure-independent valves or Energy Valves can also be installed. All these types of valves ensure **the utmost adjustment accuracy while maintaining the system's hydronic balance**.

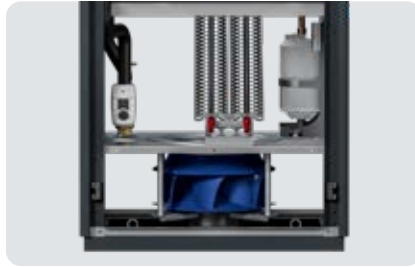

**Ventilation adjustment**

Depending on the air distribution logic in the server room, it is possible to adjust the machine on-board ventilation system to ensure **a constant air flow rate** (airflow control) or **a constant available overpressure** (ΔP control). The latter is particularly useful if a floating floor is used.



**Finned pack coil with hydrophilic coating**

All models in the JREF CW Radial range feature heat exchange coils with hydrophilic coating. This special coating - together with adequate adjustment of air through-flow speeds - **helps condensate collection and outflow during the dehumidification process, preventing any dripping on the inside and outside of the unit**.

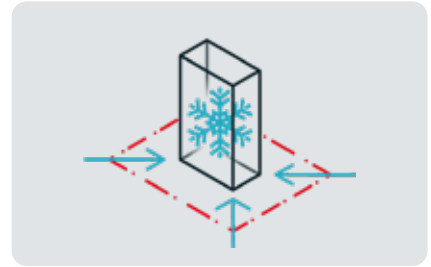

**High power density**

The reduced footprint and high efficiency **offer higher cooling capacity**. In this way **the space dedicated to the units in the Data Center is minimized, making the most of available spaces**.



**Easier scheduled maintenance**

The unit has been painstakingly designed to ensure frontal access to components. This makes **routine maintenance easier in full compliance with safety standards**.



**Extended filter section**

Air filters, located on the entire surface of the coil, **maximize the filtering section and minimize the unit's air pressure drops**.

**Double circuit**

Chilled water units are also available with a double circuit. In this version the supply is **via two different hydraulic circuits** that can offer **the utmost operational continuity if one of the two circuits malfunctions**. Each circuit is equipped with a regulating valve

JREF CW R		0150	0170	0210	0250	0270	0320
<b>Air temperature 24°C - 50% / Water temperature In 7°C Out 12°C</b>							
Cooling capacity	kW	14.6	17	21.2	24.8	27.2	31.7
EER		19.55	21.34	23.96	20.79	23.17	27.54
SHR		0.9	0.88	0.8	0.84	0.86	0.8
<b>Air temperature 30°C - 35% / Water temperature In 10°C Out 15°C</b>							
Cooling capacity	kW	17.7	20.2	21.9	27.4	31.4	32.9
EER		23.62	25.33	24.83	22.98	26.72	28.56
SHR		1	1	1	1	1	0.99
<b>Air temperature 35°C - 30% / Water temperature In 15°C Out 20°C</b>							
Cooling capacity	kW	17.8	20.3	22	27.6	31.5	32.9
EER		23.84	25.46	24.86	23.14	26.83	28.59
SHR		1	1	1	1	1	1
Rated air flow	m <sup>3</sup> /h	4130		6130		5930	
Total fan absorbed power	kW	0.8		1.2		1.1	
Power supply	V/ph/Hz	400/3+N/50					
Lp @ nominal rpm; dist.=2m Q=2	db(A)	59	60	61	62	62	62
Dimensions [LxHxD]	mm	600x2000x600			900x2000x600		

Performance data relating to Downflow versions. | Also available with 60 Hz power supply. | Height of model Displacement 2100 mm.

# JREF DX A

## Radial

### AIR CONDENSED PERIMETER MOUNTED UNITS FOR DATA CENTERS

7-25 kW



MULTI-PROTOCOL COMMUNICATION INTERFACE	SCROLL COMPRESSORS	EC RADIAL FANS	MODBUS CONTROLLED FANS
FAST RESTART	ON-BOARD HUMIDIFIER	MODULATING HOT GAS POST-HEATING	LOW GWP REFRIGERANT

The JREF DX Radials series perimeter mounted units are direct expansion units with EC radial fans designed to be installed in small-sized premises such as server rooms and labs or for applications where **accurate control of thermo-hygrometric parameters and round-the-clock operation are required**. The top priority for internal design and for the choice of components is **energy efficiency** - to **optimise the system overall electricity consumption** with a positive impact on the Data Center Power Usage Effectiveness (PUE).

The JREF DX A Radial units are air-condensed perimeter-mounted units in the JREF range; they are widely used for the cooling of Data Centers. The air-condensed solution offers **a simple system design**, thanks to the absence of auxiliary circuits and pumps; the cooling circuit is managed by the cabinet, and both the indoor unit and the remote condenser are **easy to install**.

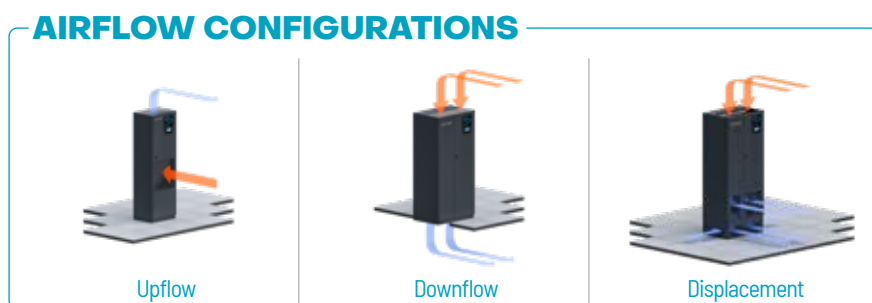

- Refrigerant R410A or R513A
- EC Fans
- Scroll on/off compressors
- Temperature control through heating and post-heating systems with electric heating elements, hot water and hot gas (optional)
- Humidity control through dehumidification and humidification (optional)
- Broad choice of accessories, including base modules and plenums for ducting
- Air filter class G3 as standard. Air Filters G4, M5, F7 (optional)
- Double power supply with automatic switch (optional)
- Constant-flow (airflow control) or constant available overpressure ( $\Delta P$  control) ventilation modulation (optional)
- Electronic expansion valves (optional)
- Low temperature kits for optimal operation in the case of installation in particularly cold environments (on request)
- Long distance kits for optimal operation in the event of large distances between indoor and outdoor units (on request)



**Efficiency**

The performance, reliability and efficiency of HiRef units are guaranteed **by using the best quality components and by cleverly designed internal and external layouts.**



**Easier scheduled maintenance**

The unit has been painstakingly designed to ensure frontal access to components. This makes **routine maintenance easier in full compliance with safety standards.**



**Safety in the server room**

All models in the JREF DX A Radial range feature heat exchange coils with hydrophilic coating. This special coating - together with adequate adjustment of air through-flow speeds - **helps condensate collection during the dehumidification process, preventing any dripping on the inside and outside of the unit.**



**Remote condensers**

All units can be combined with HiRef remote condensers, choosing from **different combinations to meet all system needs. Oversize remote condensers** are ideal for warmer environments, where it is necessary to keep the condensing temperature under control, while **the compact condensers** on the other hand are small in terms of both size and consumption. The condensers, used with dual-circuit units, are available with a single cooling circuit for **maximum reliability and redundancy of the system** or with a double cooling circuit, **to reduce installation spaces and costs.**

**Green**

HiRef is constantly committed to the **search for refrigerants with ever-lower environmental impact.** The use of ASHRAE Class A1 refrigerants, non-toxic and non-flammable, is essential for close control application.

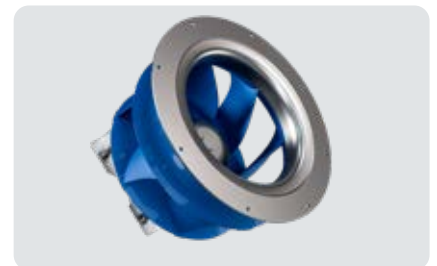

**Ventilation EC**

EC PLUG fans, standard throughout the range, are adjustable using different logics: flow rate, overpressure, constant ΔP and ΔT. Their accurate adjustment allows an efficient use of power for ventilation and **a consequent reduction of the system's PUE.** Extended range speed adjustment is carried out via Modbus protocol. The "emergency speed" function allows for fan operation **even in the event of microprocessor malfunctions.**

JREF DX A R		0060	0080	0100	0110	0130	0160	0190	0205	0212
<b>R410A - Indoor air 24°C - 50% / Outdoor air 35°C</b>										
Cooling capacity	kW	6.5	8.6	10.8	11.9	13.8	16.7	19.7	22.6	22.8
Total absorbed power	kW	2	2	3	3.3	4.5	5.2	6	6.3	6.8
EER		3.49	4.76	3.92	3.89	3.38	3.83	3.82	4.12	3.79
SHR		0.99	0.94	0.98	0.97	0.89	1	0.95	0.89	0.88
<b>R410A - Indoor air 30°C - 35% / Outdoor air 35°C</b>										
Cooling capacity	kW	7.1	9.4	12.1	13.4	15.2	18.9	22.1	24.7	24.9
Total absorbed power	kW	2	2	3.1	3.4	4.6	5.4	6.1	6.4	6.9
EER		3.71	5.14	4.33	4.32	3.63	4.17	4.16	4.43	4.09
SHR		1	1	1	1	1	1	1	1	1
<b>R513A - Indoor air 24°C - 50% / Outdoor air 35°C - 50%</b>										
Cooling capacity	kW	6.8	7.7	9.9	11.7	13.6	15.7	17.7	-	-
Total absorbed power	kW	1.8	2.2	2.4	3.1	3.5	4.6	5.2	-	-
EER		4.05	3.76	4.63	4.09	4.36	4.2	4.07	-	-
SHR		0.94	0.95	1	0.99	0.93	1	0.99	-	-
<b>R513A - Indoor air 30°C - 35% / Outdoor air 35°C - 50%</b>										
Cooling capacity	kW	7.5	8.6	11.4	13.3	15.1	18	19.9	-	-
Total absorbed power	kW	1.8	2.3	2.5	3.2	3.6	4.7	5.5	-	-
EER		4.36	4.09	5.14	4.5	4.71	4.62	4.3	-	-
SHR		1	1	1	1	1	1	1	-	-
Rated air flow	m³/h	1785	2150	3530		3700		5100		
Power supply	V/ph/Hz	400/3+N/50								
Number of circuits		1	1	1	1	1	1	1	1	2
Lp @ nominal rpm; dist.=2m 0=2	db(A)	49	50	53	53	54	55	56	56	56
Dimensions [LxHxD]	mm	600x1875x600				900x1875x600				

Also available with 60 Hz power supply. | Model height Displacement 2125 mm.



# JREF DX W/Z

## Radial



### WATER CONDENSED PERIMETER MOUNTED UNITS FOR DATA CENTERS

JREF DX W > 7-24 kW

JREF DX Z > 7-27 kW

 MULTI-PROTOCOL COMMUNICATION INTERFACE	 SCROLL COMPRESSORS	 EC RADIAL FANS
 MODBUS CONTROLLED FANS	 FAST RESTART	 ON-BOARD HUMIDIFIER
 MODULATING HOT GAS POST-HEATING	 PLATE HEAT EXCHANGER	 LOW GWP REFRIGERANT

JREF W Radial units are water-condensed perimeter-mounted cabinets and they use Dry Cooler water. The JREF units of this series are "monobloc" units inside which **the entire cooling circuit is concentrated**. Cooling is via a **brazed plate exchanger made of stainless steel AISI 304**.

JREF Z Radial units are water-condensed perimeter-mounted cabinets they use low temperature mains water or groundwater (15°C). The JREF units of this series are "monobloc" units inside which **the entire cooling circuit is concentrated**. Cooling is via a **brazed plate exchanger made of stainless steel AISI 304**.

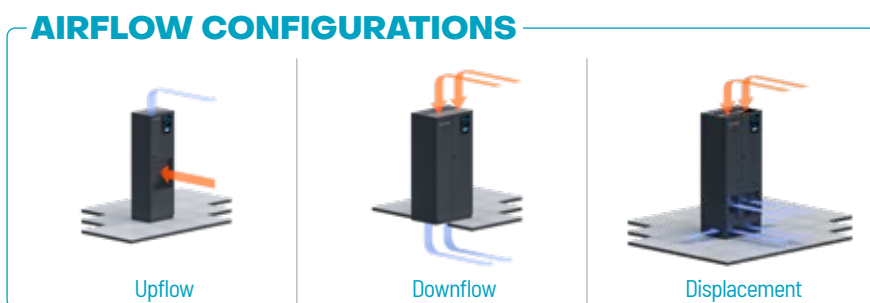
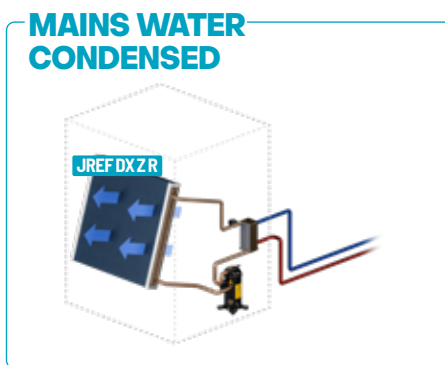
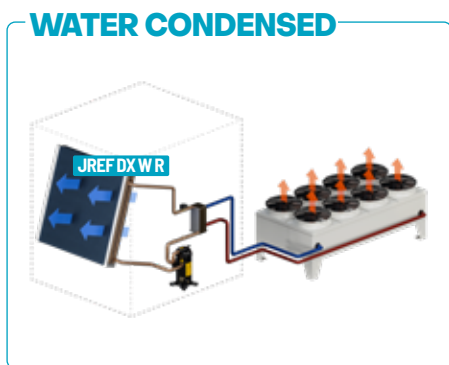

- Refrigerant R410A or R513A
- EC Fans
- Scroll on/off compressors
- Temperature control through heating and post-heating systems with electric heating elements, hot water and hot gas (optional)
- Humidity control through dehumidification and humidification (optional)
- Low temperature kits for optimal operation in the case of installation in particularly cold environments (on request)
- Broad choice of accessories, including base modules and plenums for ducting
- Air filter class G3 as standard. Air Filters G4, M5, F7 (optional)
- Double power supply with automatic switch (optional)
- Constant-flow (airflow control) or constant available overpressure ( $\Delta P$  control) ventilation modulation (optional)
- Electronic expansion valves (optional)



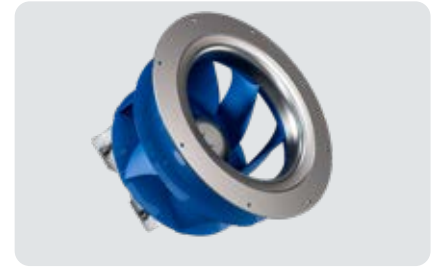

### Efficiency

The performance, reliability and efficiency of HiRef units are guaranteed **by using the best quality components and by cleverly designed internal and external layouts.**

### Green

HiRef is constantly committed to the search for refrigerants that have an increasingly **reduced environmental impact.** The use of ASHRAE Class A1 refrigerants, non-toxic and non-flammable, is essential for the “close control” application.

### Easier scheduled maintenance

The unit has been painstakingly designed to ensure frontal access to components. This makes **routine maintenance easier in full compliance with safety standards.**

### Safety in the server room

All models in the JREF W Radial range feature heat exchange coils with hydrophilic coating. This special coating - together with adequate adjustment of air through-flow speeds - **helps condensate collection during the dehumidification process, preventing any dripping on the inside and outside of the unit.**

### Ventilazione EC

I ventilatori PLUG EC, di serie su tutta la gamma, sono regolabili mediante differenti logiche: portata, sovrappressione  $\Delta P$  e  $\Delta T$  costanti. La loro puntuale regolazione consente un utilizzo efficiente dell'energia elettrica spesa per la ventilazione e una conseguente **riduzione del PUE del sistema.** La regolazione della velocità con range esteso è effettuata attraverso il protocollo Modbus. La funzione “velocità di emergenza”, infine, permette al ventilatore di muoversi **anche in caso di malfunzionamenti del microprocessore.**

JREF DX W R		0060	0080	0100	0110	0130	0160	0190	0205	0212	
<b>R410A - Indoor air 24°C - 50% / Water 40°C - 45°C</b>											
Cooling capacity	kW	6.6	8	10.5	11.5	13.6	16.3	18.9	20.8	22	
Total absorbed power	kW	1.9	2.3	3.2	3.5	4.7	5.3	6.3	7.4	7.4	
EER		3.82	3.78	3.54	3.54	3.18	3.66	3.45	3.17	3.35	
SHR		0.98	0.98	1	0.98	0.91	1	0.97	0.93	0.9	
<b>R410A - Indoor air 30°C - 35% / Water 40°C - 45°C</b>											
Cooling capacity	kW	7.3	8.8	11.8	13.2	15.1	18.7	21.5	23.1	24.2	
Total absorbed power	kW	1.9	2.3	3.2	3.5	4.7	5.3	6.4	7.5	7.4	
EER		4.12	4.17	4	4.04	3.49	4.17	3.88	3.48	3.69	
SHR		1	1	1	1	1	1	1	1	1	
<b>R513A - Indoor air 30°C - 35% / Water 40°C - 45°C</b>											
Cooling capacity	kW	6.6	7.6	9.6	11.5	12.9	15.1	16.6	-	-	
Total absorbed power	kW	1.9	2.3	2.6	3.3	3.8	4.9	5.7	-	-	
EER		3.71	3.66	4.12	3.83	3.73	3.68	3.42	-	-	
SHR		0.95	0.95	1	1	0.95	1	1	-	-	
<b>R513A - Indoor air 30°C - 35% / Water 40°C - 45°C</b>											
Cooling capacity	kW	7.4	8.6	11.1	13	14.5	17.4	19	-	-	
Total absorbed power	kW	1.9	2.3	2.7	3.3	3.9	5	5.9	-	-	
EER		4.15	4.07	4.68	4.27	4.13	4.16	3.77	-	-	
SHR		1	1	1	1	1	1	1	-	-	
JREF DX Z R		0060	0080	0100	0110	0130	0160	0190	0205	0212	
<b>R410A - Indoor air 24°C - 50% / Water 15°C - 30°C</b>											
Cooling capacity	kW	7.3	9.1	11.7	12.8	15.7	19.1	22.2	24.1	24.5	
Total absorbed power	kW	1.3	1.7	2.5	2.8	3.5	4.1	4.8	5.7	6	
EER		5.99	6.07	5.21	5.01	5.03	5.8	5.53	4.99	4.74	
SHR		0.89	0.89	0.94	0.92	0.86	0.93	0.9	0.86	0.85	
<b>R410A - Indoor air 30°C - 35% / Water 15°C - 30°C</b>											
Cooling capacity	kW	7.8	9.9	12.9	14.3	16.8	21.2	24.3	25.9	26.5	
Total absorbed power	kW	1.3	1.7	2.5	2.9	3.5	4.2	4.9	5.7	6	
EER		6.39	6.55	5.73	5.57	5.37	6.39	5.97	5.34	5.14	
SHR		1	1	1	1	1	1	1	1	1	
<b>R513A - Indoor air 24°C - 50% / Water 15°C - 30°C</b>											
Cooling capacity	kW	7.4	8.6	10.4	12.5	14.6	17	18.9	-	-	
Total absorbed power	kW	1.4	1.8	2.2	2.8	3	4	4.7	-	-	
EER		5.58	5.35	5.57	5.04	5.52	5.41	4.88	-	-	
SHR		0.88	0.91	1	0.96	0.91	1	0.95	-	-	
<b>R513A - Indoor air 30°C - 35% / Water 15°C - 30°C</b>											
Cooling capacity	kW	8.2	9.4	12	14	16	19.3	21.1	-	-	
Total absorbed power	kW	1.5	1.8	2.2	2.8	3.1	4	4.9	-	-	
EER		6.12	5.77	6.15	5.51	5.98	6.02	5.18	-	-	
SHR		1	1	1	1	1	1	1	-	-	
Rated air flow	m <sup>3</sup> /h	1785	2150	3530		3700	5100				
Power supply	V/ph/Hz						400/3+N/50				
Number of circuits		1	1	1	1	1	1	1	1	2	
Lp @ nominal rpm; dist.=2m 0=2	db(A)	49	50	53	53	54	55	56	56	56	
Dimensions [LxHxD]	mm	600x1875x600					900x1875x600				

Also available with 60 Hz power supply. | Model height Displacement 2125 mm.

# JREF CW

## Centrifugal

### CHILLED WATER PERIMETER MOUNTED UNITS FOR DATA CENTERS

7-24 kW



<p>MULTI-PROTOCOL COMMUNICATION INTERFACE</p>	<p>FAST RESTART</p>
<p>ON-BOARD HUMIDIFIER</p>	<p>CENTRIFUGAL FANS</p>

The JREF CW Centrifugal series perimeter mounted units are chilled water units with AC centrifugal fans for small-sized premises such as server rooms and labs or for applications where **accurate control of thermo-hygrometric parameters and round-the-clock operation are required**. The internal design and the choice of components are primarily aimed at **ensuring a compact design to make unit installation as easy as possible**.

- Temperature control through heating and post-heating systems using electric heating elements, additional hot water coil, or both (optional)
- Humidity control through dehumidification and humidification (optional)
- Fan speed modulation based on thermal load (constant  $\Delta T$ )
- Broad choice of accessories, including base modules and plenums for ducting
- Air filter class G3 as standard. Air Filters G4, M5, F7 (optional)
- Double power supply with automatic switch (optional)
- Instant reading of water flow rate, water inlet and outlet temperatures, or supplied cooling capacity (optional)

#### CHILLED WATER

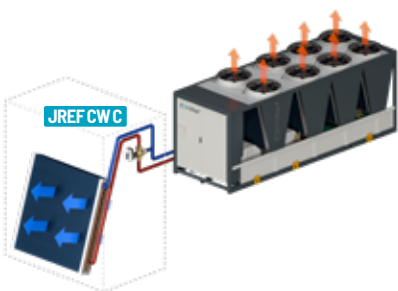

#### AIRFLOW CONFIGURATIONS



Upflow



Downflow



Displacement



### Easier scheduled maintenance

The unit has been painstakingly designed to ensure frontal access to components. This makes **routine maintenance easier in full compliance with safety standards.**



### Finned pack coil with hydrophilic coating

All models in the JREF CW Centrifugal range feature heat exchange coils with hydrophilic coating. This special coating - together with adequate adjustment of air through-flow speeds - **helps condensate collection and outflow during the dehumidification process, preventing any dripping on the inside and outside of the unit.**



### Accurate regulation with multiple types of valves

All units in the JREF CW Centrifugal range have as standard regulating valves fitted with 0-10V servo motor, selectable in 2-way execution, with variable or 3-way flow system or with servo motor with spring return. On request, pressure-independent valves or Energy Valves can also be installed. All these types of valves ensure **the utmost adjustment accuracy while maintaining the system's hydronic balance.**

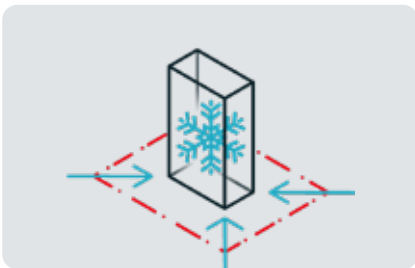

### Double circuit

Chilled water units are also available with a double circuit. In this version the supply is **via two different hydraulic circuits** that can offer the **utmost operational continuity if one of the two circuits malfunctions.** Each circuit is equipped with a regulating valve

### High power density

The reduced footprint and high efficiency **offer higher cooling capacity.** In this way **the space dedicated to the units in the Data Center is minimized, making the most of available spaces.**



JREF CW C		0080	0110	0140	0160	0200	0230
<b>Air temperature 24°C - 50% / Water temperature In 7°C Out 12°C</b>							
Cooling capacity	kW	6.9	10	12.8	14.5	18.7	20.8
EER		31.27	35.76	22.84	25.83	27.86	31.06
SHR		0.87	0.85	0.88	0.87	0.88	0.85
<b>Air temperature 30°C - 35% / Water temperature In 10°C Out 15°C</b>							
Cooling capacity	kW	8.8	10.7	15.3	17	21.8	23.7
EER		40	38.09	27.34	30.44	32.53	35.35
SHR		0.94	1	1	1	1	1
<b>Air temperature 35°C - 30% / Water temperature In 15°C Out 20°C</b>							
Cooling capacity	kW	8.9	10.7	15.4	17.1	22	23.8
EER		40.25	38.24	27.53	30.56	32.77	35.49
SHR		0.94	1	1	1	1	1
Rated air flow	m <sup>3</sup> /h	1785	2150	3530	3470	5115	4990
Total fan absorbed power	kW	0.2	0.3		0.6		0.7
Power supply	V/ph/Hz				400/3+N/50		
Lp @ nominal rpm; dist.=2m Q=2	db(A)	48	50	51	51	52	52
Dimensions [LxHxD]	mm	600x1875x449		900x1875x449		1200x1875x449	

Performance data relating to Downflow versions. | Also available with 60 Hz power supply. | Model height Displacement 2125 mm.

# JREF DX A

## Centrifugal

### AIR CONDENSED PERIMETER MOUNTED UNITS FOR DATA CENTERS

7-24 kW

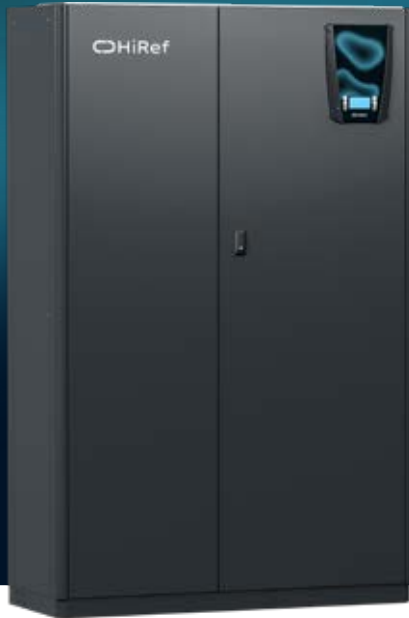

MULTI-PROTOCOL COMMUNICATION INTERFACE	SCROLL COMPRESSORS	FAST RESTART	ON-BOARD HUMIDIFIER
CENTRIFUGAL FANS	MODULATING HOT GAS POST-HEATING	LOW GWP REFRIGERANT	

The JREF DX Centrifugal units are direct expansion units with centrifugal AC fans designed to be installed in small-sized premises such as server rooms and labs or for applications where **accurate control of thermo-hygrometric parameters and round-the-clock operation are required**. The internal design and the choice of components are primarily aimed at **ensuring a compact design to make unit installation as flexible as possible**.

JREF DX A Centrifugal units are air-condensed perimeter-mounted units in the JREF range; they are widely used for the cooling of Data Centers. The air-condensed solution offers **simple system design**, thanks to the absence of auxiliary circuits and pumps; the cooling circuit is managed by the cabinet, and both the indoor unit and the remote condenser are **easy to install**.

- Refrigerant R410A
- Scroll on/off compressors
- Temperature control through heating and post-heating systems with electric heating elements, hot water and hot gas (optional)
- Humidity control through dehumidification and humidification (optional)
- Broad choice of accessories, including base modules and plenums for ducting
- Air filter class G3 as standard. Air Filters G4, M5, F7 (optional)
- Double power supply with automatic switch (optional)
- Electronic expansion valves (optional)
- Low temperature kits for optimal operation in the case of installation in particularly cold environments (on request)
- Long distance kits for optimal operation in the event of large distances between indoor and outdoor units (on request)

#### AIR CONDENSED

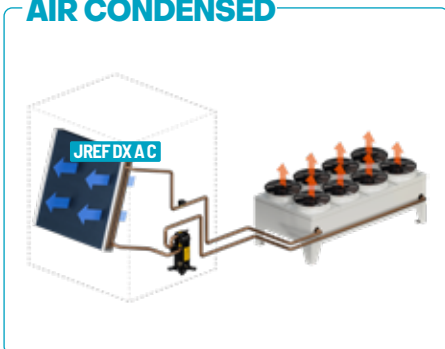

#### AIRFLOW CONFIGURATIONS

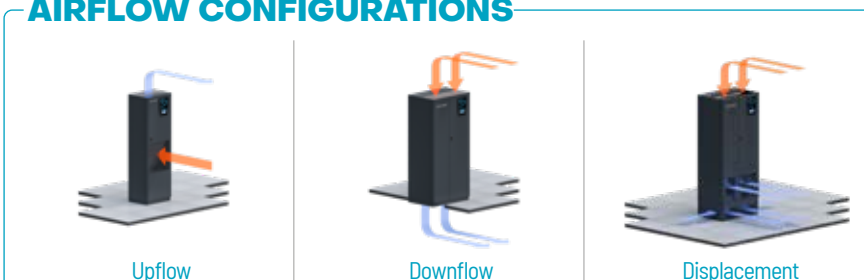



**Easier scheduled maintenance**

The unit has been painstakingly designed to ensure frontal access to components even with the units running. This makes **routine maintenance easier in full compliance with safety standards.**



**Efficiency**

The performance, reliability and efficiency of HiRef units are guaranteed **by using the best quality components and by cleverly designed internal and external layouts.**



**Safety in the server room**

All models in the JREF DX A Centrifugal range feature heat exchange coils with hydrophilic coating. This special coating - together with adequate adjustment of air through-flow speeds - **helps condensate collection during the dehumidification process, preventing any dripping on the inside and outside of the unit.**



**Green**

HiRef is constantly committed to the search for refrigerants with ever-lower environmental impact. The use of ASHRAE Class A1 refrigerants, non-toxic and non-flammable, is essential for close control application.

**Remote condensers**

All units can be combined with HiRef remote condensers, choosing from **different combinations to meet all system needs.** **Oversize remote condensers** are ideal for warmer environments, where it is necessary to keep the condensing temperature under control, while **the compact condensers** on the other hand are small in terms of both size and consumption. The condensers, used with dual-circuit units, are available with a single cooling circuit for **maximum reliability and redundancy of the system** or with a double cooling circuit, **to reduce installation spaces and costs.**



JREF DX A C		0060	0080	0100	0110	0130	0160	0190	0205
<b>R410A - Indoor air 24°C - 50% / Outdoor air 35°C</b>									
Cooling capacity	kW	6.5	8.6	11.2	12.3	14.6	16.2	19.7	22.6
Total absorbed power	kW	2.1	2.1	3.3	3.6	4.7	5	5.8	6.2
EER		3.52	4.79	4.06	4.01	3.53	3.71	3.82	4.12
SHR		0.99	0.94	0.99	0.95	0.9	0.98	0.94	0.87
<b>R410A - Indoor air 30°C - 35% / Outdoor air 35°C</b>									
Cooling capacity	kW	7.1	9.4	12.4	13.7	16	18.3	21.9	24.4
Total absorbed power	kW	2.2	2.1	3.4	3.7	4.8	5.2	6	6.2
EER		3.7	5.19	4.43	4.39	3.79	4.08	4.12	4.39
SHR		1	1	1	1	1	1	1	1
Rated air flow	m <sup>3</sup> /h	1785	2150	3690	3530	3470	5115	4990	
Power supply	V/ph/Hz	400/3+N/50							
Number of circuits		1	1	1	1	1	1	1	1
Lp @ nominal rpm; dist.=2m Q=2	db(A)	46	48	48	49	51	52	53	53
Dimensions [LxHxD]	mm	600x1875x449			900x1875x449			1200x1875x449	

Performance data relating to Downflow versions with R410A refrigerant combined with standard HiRef remote condenser. | Also available with 60 Hz power supply. | Model height Displacement 2125 mm.

# JREF DX W/Z



## Centrifugal

### WATER CONDENSED PERIMETER MOUNTED UNITS FOR DATA CENTERS

JREF DX W > 7-24 kW

JREF DX Z > 7-28 kW



 MULTI-PROTOCOL COMMUNICATION INTERFACE	 SCROLL COMPRESSORS	 FAST RESTART	 ON-BOARD HUMIDIFIER
 PLATE HEAT EXCHANGER	 CENTRIFUGAL FANS	 MODULATING HOT GAS POST-HEATING	 LOW GWP REFRIGERANT

JREF W Centrifugal units are water-condensed perimeter-mounted cabinets, and they use Dry Cooler water. The JREF units of this series are “monobloc” units inside which **the entire cooling circuit is concentrated**. Cooling is via a **brazed-plate exchanger made of stainless steel AISI 304**. All W units can be paired with **HiRef Dry Coolers**.

JREF Z Centrifugal units are water-condensed perimeter-mounted cabinets, and they use low temperature mains water or groundwater (15°C). The JREF units of this series are “monobloc” units inside which **the entire cooling circuit is concentrated**. Cooling is via a **brazed plate exchanger made of stainless steel AISI 304**.

- Refrigerant R410A
- Scroll on/off compressors
- Temperature control through heating and post-heating systems with electric heating elements, hot water and hot gas (optional)
- Humidity control through dehumidification and humidification (optional)
- Low temperature kits for optimal operation in the case of installation in particularly cold environments (on request)
- Broad choice of accessories, including base modules and plenums for ducting
- Air filter class G3 as standard. Air Filters G4, M5, F7 (optional)
- Double power supply with automatic switch (optional)
- Electronic expansion valves (optional)

#### WATER CONDENSED

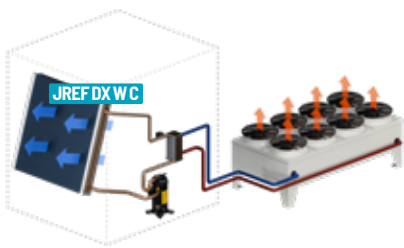

#### MAINS WATER CONDENSED

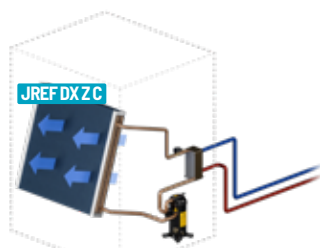

#### AIRFLOW CONFIGURATIONS



Upflow



Downflow



Displacement



### Easier scheduled maintenance

The unit has been painstakingly designed to ensure frontal access to components even with the units running. This makes **routine maintenance easier in full compliance with safety standards.**

### Efficiency

The performance, reliability and efficiency of HiRef units are guaranteed **by using the best quality components and by cleverly designed internal and external layouts.**

### Safety in the server room

All models in the JREF W/Z Centrifugal range feature heat exchange coils with hydrophilic coating. This special coating - together with adequate adjustment of air through-flow speeds - **helps condensate collection during the dehumidification process, preventing any dripping on the inside and outside of the unit.**

### Green

HiRef is constantly striving to find refrigerants with an ever decreasing environmental impact. The use of ASHRAE class A1, non-toxic and non-flammable refrigerants is essential in close control applications.



JREF DX W C		0060	0080	0100	0110	0130	0160	0190	0205
<b>R410A - Indoor air 24°C - 50% / Water 40°C - 45°C</b>									
Cooling capacity	kW	6.7	8.1	11	12.1	14.9	16.3	19.8	21.8
Total absorbed power	kW	1.9	2.4	3.4	3.7	4.6	4.8	5.7	6.7
EER		3.91	3.92	3.82	3.81	3.66	3.91	3.9	3.63
SHR		0.97	0.97	0.99	0.97	0.9	0.98	0.94	0.89
<b>R410A - Indoor air 30°C - 35% / Water 40°C - 45°C</b>									
Cooling capacity	kW	7.4	9	12.3	13.6	16.3	18.4	22	23.7
Total absorbed power	kW	2	2.3	3.4	3.7	4.6	4.8	5.7	6.7
EER		4.25	4.38	4.32	4.33	4	4.42	4.33	3.95
SHR		1	1	1	1	1	1	1	1
Rated air flow	m <sup>3</sup> /h	1785	2150	3690	3530	3470	5115	4990	
Power supply	V/ph/Hz	400/3+N/50							
Number of circuits		1	1	1	1	1	1	1	1
Lp @ nominal rpm; dist.=2m 0=2	db(A)	46	48	48	49	51	52	53	53
Dimensions [LxHxD]	mm	600x1875x449			900x1875x449			1200x1875x449	

Performance data relating to Downflow versions with R410A refrigerant. | Also available with 60 Hz power supply. | Model height Displacement 2125 mm.

JREF DX Z C		0060	0080	0100	0110	0130	0160	0190	0205
<b>R410A - Indoor air 24°C - 50% / Water 15°C - 30°C</b>									
Cooling capacity	kW	7.4	9.3	12.4	14	17.1	19.5	23.7	25.8
Total absorbed power	kW	1.4	1.7	2.6	3	3.5	3.7	4.4	5
EER		6.29	6.5	6.02	5.84	5.78	6.35	6.39	5.9
SHR		0.89	0.88	0.92	0.89	0.84	0.88	0.86	0.82
<b>R410A - Indoor air 30°C - 35% / Water 15°C - 30°C</b>									
Cooling capacity	kW	8	10.1	13.5	15.5	18.3	21.4	25.5	27.7
Total absorbed power	kW	1.4	1.7	2.6	2.9	3.5	3.7	4.4	5
EER		6.81	7.07	6.59	6.51	6.2	6.94	6.88	6.32
SHR		1	1	1	1	1	1	1	0.99
Rated air flow	m <sup>3</sup> /h	1785	2150	3690	3530	3470	5115	4990	
Power supply	V/ph/Hz	400/3+N/50							
Number of circuits		1	1	1	1	1	1	1	1
Lp @ nominal rpm; dist.=2m 0=2	db(A)	46	48	48	49	51	52	53	53
Dimensions [LxHxD]	mm	600x1875x449			900x1875x449			1200x1875x449	

Performance data relating to Downflow versions with R410A refrigerant. | Also available with 60 Hz power supply. | Model height Displacement 2125 mm.

# FanWall HBCV

FANWALL AIR CONDITIONERS CHILLED WATER OR DIRECT EXPANSION VERSIONS FOR HIGH DENSITY HYPERSCALE DATA CENTER

45-461 kW



 MULTI-PROTOCOL COMMUNICATION INTERFACE	 EC RADIAL FANS	 MODBUS CONTROLLED FANS	 PRESSURE INDEPENDENT VALVE (PICV)
 FAST RESTART	 VARIABLE GEOMETRY COIL (FLEXY)	 DOUBLE CIRCUIT	

The FanWall HBCV series of chilled water air conditioners are designed for technological environments where a reduced footprint is required while maintaining the same cooling capacity. An in-depth CFD (computational fluid dynamics) analysis has allowed every last constructive detail to be designed so as **to minimise internal airflow pressure drops and, therefore, fan power consumption**. At the same time, the large surface of the finned pack exchanger **minimises the approach temperatures between inlet air and outlet water, maximising system efficiency**.

- Stainless steel condensate drain pan
- Fan speed modulation based on thermal load (constant  $\Delta T$ )
- Constant-flow ventilation modulation (Airflow Control), optional
- Dual power supply with automatic switch (optional)
- Instantaneous reading of the supplied cooling capacity (optional)
- Harmonic filters (optional)
- ON/OFF damper (optional)



## CHILLED WATER

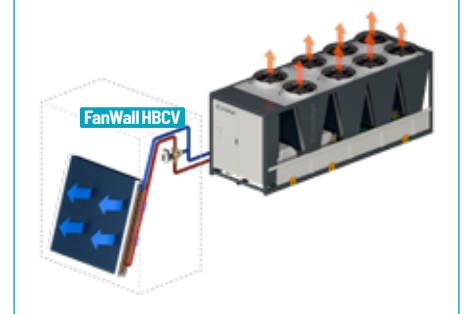



### Ventilation EC 2.0

The use of standard-equipment EC plug fans across the whole range - designed to adjust the air flow according to the thermal load - results in efficient use of the electricity for ventilation purposes, **with a positive impact on the system PUE**. Extended range speed adjustment is carried out via MODBUS protocol. The emergency speed function allows for fan operation consistency **even in the event of microprocessor malfunctions**.

### Maximum possible redundancy

To ensure system operation continuity, the FanWall HBCV range makes it possible to have a **fully redundant refrigeration circuit**: a double coil and double water adjustment valve allow the server room to be cooled **even when either circuit fails**.

### Ventilation adjustment

Depending on the air distribution logic in the server room, it is possible to adjust the machine on-board ventilation system to ensure a **constant air flow rate** (airflow control) or a **constant available overpressure** ( $\Delta P$  control). The latter is particularly useful if a floating floor is used.

### Accurate regulation with multiple types of valves

All units in the FanWall HBCV range are equipped as standard with control valves featuring a 0-10V servomotor, available in 2-way configuration for variable flow systems or 3-way, or with a spring-return servomotor. On request, pressure-independent valves or Energy Valves can also be installed. All these types of valves ensure **maximum control precision while maintaining the hydronic balance of the system**.

### Finned pack coil with hydrophilic coating

All models in the FanWall HBCV range feature heat exchange coils with hydrophilic coating. This special coating - together with adequate adjustment of air through-flow speeds - **helps condensate collection and outflow during the dehumidification process, preventing any dripping on the inside and outside of the unit**.

### Blown finned coil

According to a specific design choice, this finned coil is installed downstream of the fans. This ensures a more even distribution of the delivery air to the racks, **minimising turbulence in the air flow**.

### Easier scheduled maintenance

The unit has been designed with the utmost care to grant front (air inlet side) access to internal components even with the units running. This configuration allows the maintenance technician to work safely inside the technical corridor and facilitates routine maintenance operations, fully complying with safety requirements.



FANWALL HBCV		051B	102B	121B	171B	242B	342B
<b>Air temperature 30°C - 35% / Water temperature In 10°C Out 18°C</b>							
Cooling capacity	kW	48.5	97	118.2	173.4	236.4	346.8
EER		69.3	69.29	62.21	59.79	62.21	59.79
SHR		1	1	1	1	1	1
<b>Air temperature 30°C - 35% / Water temperature In 10°C Out 22°C</b>							
Cooling capacity	kW	44.9	89.8	110.2	164.4	220.4	328.8
EER		64.1	64.1	58	56.7	58	56.7
SHR		1	1	1	1	1	1
<b>Air temperature 35°C - Relative humidity 25% / Water temperature In 10°C Out 18°C</b>							
Cooling capacity	kW	63.7	127.4	157.1	230.3	314.2	460.6
EER		91	91	82.68	79.41	82.68	79.41
SHR		1	1	1	1	1	1
<b>Air temperature 35°C - Relative humidity 25% / Water temperature In 10°C Out 22°C</b>							
Cooling capacity	kW	60.6	121.2	148.9	219.8	297.8	439.6
EER		86.6	86.6	78.4	75.8	78.4	75.8
SHR		1	1	1	1	1	1
Rated air flow	m <sup>3</sup> /h	8700	17400	21200	31100	42400	62200
Total fan absorbed power	kW	0.7	1.4	1.9	2.9	3.8	5.8
Power supply	V/ph/Hz	400/3+N/50					
Dimensions [LxHxD]	mm	1500x1475x1300	1500x2950x1300	2950x1475x1300	4000x1475x1300	2950x2950x1300	4000x2950x1300

Data declared for chilled water version. | Also available with 60 Hz power supply. | The dimensions shown refer to standard models but can be customised according to application requirements.

# HTI CW

## CHILLED WATER UNITS FOR MEDIUM/SMALL SERVER ROOMS

8-45 kW

 <p>MULTI-PROTOCOL COMMUNICATION INTERFACE</p>	 <p>EC RADIAL FANS</p>	 <p>MODBUS CONTROLLED FANS</p>
---	---	---



HTI CW units are split-type air conditioners intended for small and medium-sized Data Centers. Designed for **ceiling or wall mounting**, they are suitable for air conditioning of control centres with limited internal space or space entirely taken up by technological equipment. Thanks to the **rational layout of components and wide range of available accessories**, these units are **easy to install and suitable for different shelter configurations**.

- Temperature control through heating and post-heating systems with electric heating elements (optional)
- Humidity control through dehumidification and humidification with external humidifier (optional)
- Fan speed modulation based on thermal load (constant  $\Delta T$ )
- Version available with dual power supply for emergencies: 230/400V network and 24/48VDC backup supply
- Epoxy powder painted structural metalwork supplied as standard
- Air filter class G3 as standard. Air Filters G4, M5, F7 (optional)
- Instant water inlet/outlet temperature reading function (optional)

### CHILLED WATER

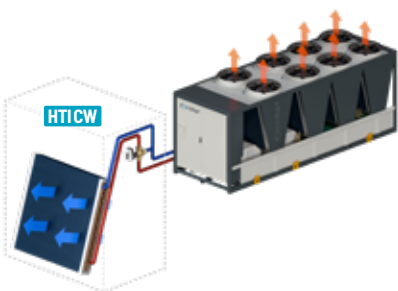

### INSTALLATION



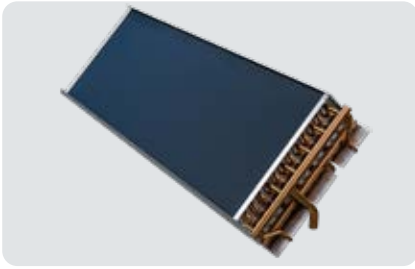

**Finned pack exchanger with hydrophilic coating.**

All models in the HTI CW range feature heat exchange coils with hydrophilic coating. This special coating - together with adequate adjustment of air through-flow speeds - **helps condensate collection during the dehumidification process, preventing any dripping on the inside and outside of the unit.**



**Ventilation EC**

EC PLUG fans, standard on the entire range, make it possible to vary the air flow according to the thermal load. Their accurate adjustment allows an efficient use of power for ventilation and **a consequent reduction of the system's PUE.** Extended range speed adjustment is carried out via Modbus protocol. The "emergency speed" function allows for fan operation **even in the event of microprocessor malfunctions.**



**Maximised Redundancy**

In case of mains power + uninterruptible power supply in direct current (DUAL), the (optional) Free-Cooling mode ensures correct internal thermal conditions, **even in the event of blackouts.** This ensures the **continuity of service of the system.**



**Simple and fast installation**

The units can be installed, as needed, on the ceiling or on the wall. Thanks to the use of EC PLUG fans, air conditioners in the HTI CW series guarantee: **optimal air distribution, efficiency, energy savings, reliability and compactness,** whatever the configuration chosen.



**Easier scheduled maintenance**

The unit has been painstakingly designed to ensure frontal access to components. This aspect, combined with the complete extractibility of filters and Free-Cooling damper (if present), **greatly facilitates routine maintenance operations.**



**Accurate regulation with multiple types of valves**

All units in the HTI CW range have as standard regulating valves fitted with 0-10V servo motor, selectable in 2-way execution, with variable or 3-way flow system. On request, pressure-independent valves or Energy Valves can also be installed. All these types of valves ensure **the utmost adjustment accuracy while maintaining the system's hydronic balance.**

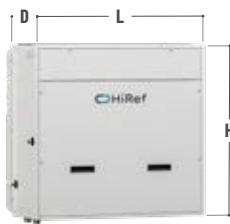

HTI CW	0073	0105	0120	0145	0310	0380	
<b>Air temperature 27°C - Relative humidity 40% / Water temperature In 7°C Out 12°C</b>							
Cooling capacity	kW	8.9	10.1	13.1	14.6	38.4	45.4
EER		52.88	51.03	52.11	49.35	33.25	36.78
SHR		0.82	0.78	0.83	0.79	0.92	0.85
<b>Air temperature 30°C - 35% / Water temperature In 10°C Out 15°C</b>							
Cooling capacity	kW	7.9	8.5	11.5	12.5	36.3	41.7
EER		47.07	43.27	45.54	42.39	31.37	33.78
SHR		0.94	0.9	0.96	0.91	1	0.95
<b>Air temperature 35°C - 30% / Water temperature In 15°C Out 20°C</b>							
Cooling capacity	kW	7.9	8.4	11.3	12.4	35.6	41.8
EER		46.89	42.89	44.76	42.02	30.84	33.82
SHR		0.98	0.96	1	0.96	1	0.99
Rated air flow	m <sup>3</sup> /h	1300		1950		7000	
Total fan absorbed power	kW	0.2		0.3		1.2	
Power supply	V/ph/Hz	230/1/50				400/3+N/50	
Lp @ nominal rpm; dist.=2m Q=2	db(A)	53	55	54	56	66	66
Dimensions [LxHxD]	mm	1050x358x936		1150x408x1026		1500x685x1096	

Also available with 60 Hz power supply. | Units can only be installed on the ceiling for sizes 0310-0381.

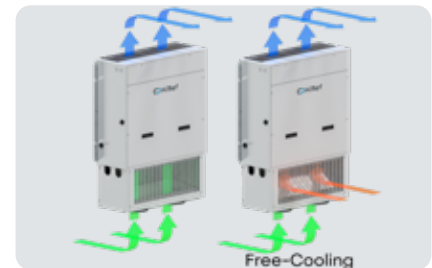

**Maximised energy saving with direct Free-Cooling**

The units can, on request, be equipped with a direct Free-Cooling module. This system, which can also be installed inside an already operational unit, reduces the work of the chiller units in generating chilled water (partial Free-Cooling), and in a state of complete Free-Cooling can be switched off. **This naturally has an important effect on the system's PUE.**



# **EVAPORATIVE AIR CONDITIONER AIR-TO-AIR**

# DataBatic

## AIR/AIR SYSTEMS FOR DATA CENTERS WITH ADIABATIC SYSTEM

10-330 kW



MULTI-PROTOCOL COMMUNICATION INTERFACE	REFRIGERANT R744 (CO <sub>2</sub> )	SCROLL COMPRESSORS	ADIABATIC COOLING
EC RADIAL FANS	MODBUS CONTROLLED FANS	INVERTER DRIVEN COMPRESSORS	FAST RESTART
ON-BOARD HUMIDIFIER	CORROSION RESISTANT MATERIAL	CROSS-FLOW HEAT RECOVERY UNIT	LOW GWP REFRIGERANT

The combination of the evaporative cooling system with the air/air cross-flow exchanger of the HDB-DataBatic range **extends indirect Free-Cooling for more hours during the year and more climate zones**. The reduction, and in some cases cessation, of mechanical operation has two benefits: **it reduces operating costs for greater annual energy efficiency** (reduced PUE) and **reduces deployment costs, thanks to the lower installed power**. HDB units can accommodate the “cooling circuit” option, and are **entirely factory assembled** in a **monobloc solution** to **facilitate installation operations**.

### Direct expansion or chilled water integration

If external climatic conditions cannot satisfy internal load requirements using only indirect Free-Cooling + Evaporative Cooling, the mechanical cooling system comes into play. There is thus the option of a cooling circuit with **BLDC modulating compressors, electronically controlled expansion valve and hydrophilically treated fin evaporator**. Alternatively, a chilled water coil can be installed, to be connected to an external chiller.

### Evaporative cooling on the air flow from the outside

HDB - DataBatic units are equipped with **Evaporative Cooling technology**, based on the use of nozzles that spray water onto the air flow coming from outside. Evaporating water cools the air due to an adiabatic effect, the air then passes the cross-flow exchanger at a temperature close to the wet bulb temperature, **extending the period of time in which it is possible to exploit the Free-Cooling effect**. Finally, the system is of the **multistep type** in respect of the air flow, in order to **optimize saturation efficiency**.

- Possibility of managing multiple units in parallel in the same system
- High efficiency through-flow heat exchanger with epoxy surface treatment for protection against corrosion (Eurovent certification)
- Management of overpressure in the air distribution plenum ( $\Delta P$  Control)
- Side and front access to all components, even when units are operational, to make maintenance easier and avoid system downtime situations
- Panelling developed and assembled in accordance with standard UNI 1886
- Air renewal kit with modulating dampers (optional)
- Ultrasonic humidifier (optional)
- Kit for applications at low outdoor air temperatures (up to  $-40^{\circ}\text{C}$ ) (optional)



$$WUE = \frac{\text{Annual Water Usage}}{\text{IT Equipment Energy}} \text{ [ l / kWh ]}$$

**Plug type fans with EC motor**

- EC type ventilation on both air flows provides:
- higher efficiency at partial loads;
  - reduced noise emissions;
  - precise tracking of thermal load variations.
- Fan consumption, in the "hot swappable" configuration, can be displayed in real time on the machine's display

**Water saving function and legionella-free system**

Pump adjustment logic, of the electronic and modulating type, makes it possible to **optimize air saturation** and at the same time Water Usage Effectiveness (WUE) and energy consumption. The particular configuration of the hydraulic circuit and the algorithms used for its management guarantee **the necessary replenishment of water in the system** to avoid high salt concentrations **and prevent water from stagnating in the collection tank**, with the risk of the spread of legionellosis.

**Indirect Air-Side Free-Cooling**

- Indirect Air-Side Free-cooling Indirect Free-Cooling, as opposed to direct:
- does not create contamination between the indoor air of the Data Center and outdoor air;
  - blocks the entry of dust and pollutants into the Data Center without the need for additional filtering;
  - It does not increase the latent load.
- The result is **a clear reduction in energy consumption for system management.**

**DESIGNED FOR INSTALLATION ON ROOF OR ON THE WALL OF THE DATA CENTER**

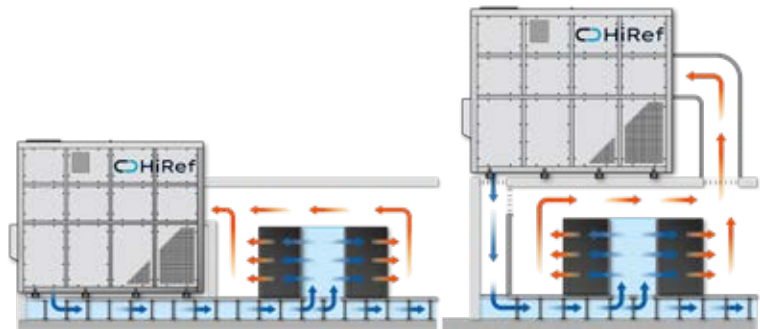

Example of use for a 1 MW Data Center (Redundancy N+1) in Amsterdam at 36°C -25%; Air temp. 24°C; Max air temp. in 26°C

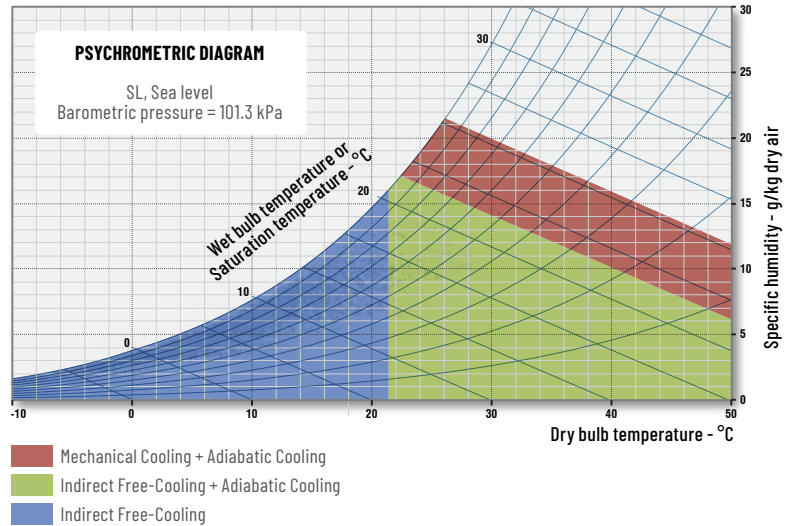

HDC DATABATIC		0060	0100	0200	0300
<b>Air temperature 36°C - Relative humidity 25% / Supply air temperature 24°C/ SHR = 1 / Outdoor air temperature 35°C - Relative humidity 30%</b>					
<b>Minimum cooling capacity</b>	kW	10	60	100	200
<b>Maximum cooling capacity</b>	kW	60	100	200	330
<b>Rated air flow</b>	m³/h	15000	27000	53000	82500
<b>Power supply</b>	V/ph/Hz	400/3+N/50			
<b>Dimensions [LxHxD]</b>	mm	2750x2650x1180	4200x2650x2250	4700x3600x2250	4700x3600x3100

Data declared with chilled water or direct expansion circuit working in top up cooling mode. | Also available with 60 Hz power supply. | Dimensions refer to the base configuration of the unit, without adiabatic system and accessories, in the version with Free Cooling and integration.



# HIGH DENSITY COOLING

# NRCD/NRCV

## DIRECT EXPANSION AIR CONDITIONERS FOR HIGH DENSITY RACKS WITH MODULATING COMPRESSORS

NRCD > 12-50 kW

NRCV > 13-37 kW



MULTI-PROTOCOL COMMUNICATION INTERFACE	EC RADIAL FANS	MODBUS CONTROLLED FANS	SCROLL COMPRESSORS
INVERTER DRIVEN COMPRESSORS	HOT-SWAPPABLE FANS	ON-BOARD HUMIDIFIER	

The rack coolers in the NRCD range are an ideal solution for the cooling of small-to-medium size Data Center racks where **precision control of hygrothermal parameters is required 24/7**. They are particularly suitable for **small installations** where a chiller cannot be installed or where water in the Data Center is not allowed. Internal design and component selection focus on the achievement of **very high energy efficiency levels to minimise running costs of the entire system**. NRCD units also have an external remote condenser, which guarantees efficiency and reliability. Depending on how rack cooling is done - by creating hot and cold aisles in the Data Center via compartmentalisation and localised cooling - the NRCD range comes in two different configurations.

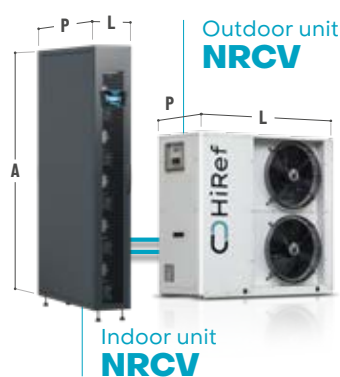
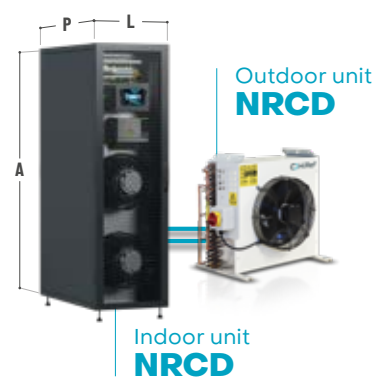
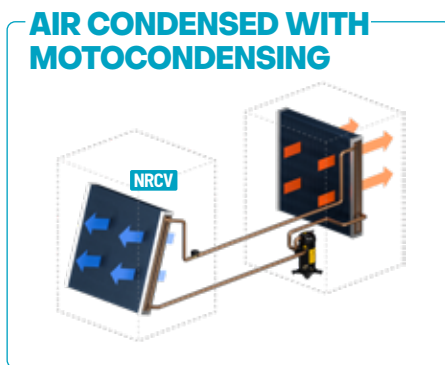

- Refrigerant R410A
- EC Fans
- Twin rotary and Scroll inverter compressors
- Electronic expansion valves (optional)
- Advanced programmable microprocessor control with LCD display
- Humidity control through dehumidification and humidification (optional)
- Air filter class G3 as standard. Air Filters G4, M5, F7 (optional)
- Double power supply with automatic switch (optional)
- Constant-flow (airflow control) or constant available overpressure ( $\Delta P$  control) ventilation modulation (optional)
- Low temperature kits for optimal operation in the case of installation in particularly cold environments (on request)



**Hot swappable fans**

In order to minimize machine shut-down, **a failed fan can be replaced without turning off the unit**, thanks to the use of the protective basket and connectors for the power and control section. Fan replacement thus becomes a routine maintenance operation.



**Safety in the server room**

All models in the NRCD range feature heat exchange coils with hydrophilic coating. This special coating - together with adequate adjustment of air through-flow speeds - **helps condensate collection during the dehumidification process, preventing any dripping on the inside and outside of the unit.**

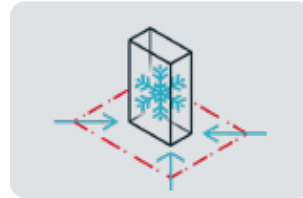

**High power density**

The internal design and the special component layout allows for an evaporating coil **with an extensive heat exchange surface area.** The unit footprint is still small, **ensuring optimal use of space in the server room.**



**Ventilation EC**

EC PLUG fans, standard throughout the range, are adjustable using different logics: flow rate, overpressure, constant  $\Delta P$  and  $\Delta T$ . Their accurate adjustment allows an efficient use of power for ventilation and a consequent **reduction of the system's PUE.** Extended range speed adjustment is carried out via Modbus protocol. The "emergency speed" function allows for fan operation **even in the event of microprocessor malfunctions.**

In-Rack or In-Row configuration.

**IN RACK:**

Configuration that generates a closed circuit between rack cooler and rack cabinet. The air can be drawn in and delivered from the right, left or both directions.

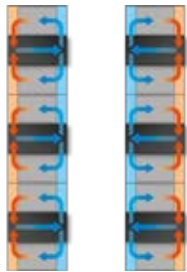

**IN ROW:**

Configuration in which cold air is released into the "cold aisle" to each rack cabinet, and hot air from the surrounding environment is drawn in by the rack cooler. The air can be delivered from the front, right and left.

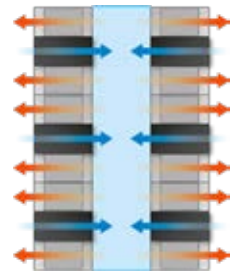

**Sliding control panel**

For 300 mm wide structures, the electrical panel is designed to take up **as little space as possible without interfering with air distribution over the whole working height of the unit.** A "sliding drawer" structure has been used, making access possible during commissioning and extraordinary maintenance operations. This configuration also prevents tangling of the wiring.

NRCD		0100	0200	0300	0260	0400	0450
<b>R410A - Indoor air 30°C - 35% / Outdoor air 35°C</b>							
Cooling capacity	kW	12.4	21.8	29.4	26.1	41.3	46.2
Total absorbed power	kW	3.4	8.2	12.4	8.1	13.1	16.1
EER		3.9	2.89	2.55	3.46	3.59	3.18
SHR		1	0.91	0.82	1	1	0.99
<b>R410A - Indoor air 35°C - 30% / Outdoor air 35°C</b>							
Cooling capacity	kW	13.1	23.6	31.6	28.6	45.5	50.1
Total absorbed power	kW	3.5	8.4	12.7	8.2	13.4	16.6
EER		4.04	3.07	2.67	3.75	3.85	3.33
SHR		1	0.95	0.85	1	1	1
Rated air flow	m <sup>3</sup> /h	2700	4000	4250	5000	9000	
Power supply	V/ph/Hz	230/1/50		400/3+N/50			
Number of circuits		1	1	1	1	1	1
Lp @ nominal rpm; dist.=2m 0=2	db(A)	64	66	67	60	73	73
Dimensions [LxHxD]	mm	300x2000x1200			600x2000x1200		

Performance data relating to units combined with standard HiRef remote condensers | Also available with 60 Hz power supply.

NRCV		0140	0240	0330
<b>R410A - Indoor air 30°C - 35% / Outdoor air 35°C</b>				
Cooling capacity	kW	13.3	24.6	34.6
Total absorbed power	kW	4.1	9.1	13.1
EER		4.06	3.17	3.1
SHR		1	1	0.88
<b>R410A - Indoor air 35°C - 30% / Outdoor air 35°C</b>				
Cooling capacity	kW	14.5	26.9	37.4
Total absorbed power	kW	4.1	9.3	13.3
EER		4.36	3.36	3.3
SHR		1	1	0.91
Rated air flow rate indoor unit	m <sup>3</sup> /h	3100	5300	
Rated air flow rate outdoor unit	m <sup>3</sup> /h	6400	9300	16300
Power supply indoor unit	V/ph/Hz	230/1/50		400/3+N/50
Power supply outdoor unit	V/ph/Hz	230/1/50	230/1/50	400/3+N/50
Number of circuits		1	1	1
Dimensions indoor unit [LxHxD]	mm	300x2000x1200		
Dimensions outdoor unit [LxHxD]	mm	1250x460x882	1565x605x1275	1965x950x1322

Total absorbed power relating to indoor unit and motocondensing unit. | Also available with 60 Hz power supply.

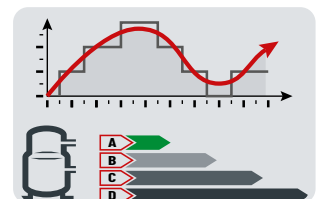

**Power modulation**

The units adapt quickly to the Data Center's cooling requests. Thanks to the inverter-controlled compressor, performance can be modulated to **up to 25% of the rated value, thus reducing consumption.** This ensures **continuous operation of the unit even at low loads**, without switching cycles on and off.

# HRCC

## CHILLED WATER AIR CONDITIONING UNITS FOR HIGH POWER DENSITY RACKS

20-57 kW



MULTI-PROTOCOL COMMUNICATION INTERFACE	EC RADIAL FANS	MODBUS CONTROLLED FANS
HOT SWAPPABLE FANS	ON-BOARD HUMIDIFIER	

HRCC units are chilled water cooler racks. They offer an ideal solution for the cooling of Data Center racks where **precision control of hygrothermal parameters is required 24/7**. They are particularly suitable for integration into chilled water systems with Free-Cooling chillers, given the possibility of making these air conditioners work even with **higher water temperatures than the usual 7/12°C or 10/15°C values**. The internal design and the choice of components are aimed at obtaining **high levels of energy efficiency and guaranteeing service continuity**, the second being a key requirement in this type of application with **high/very high power density**.

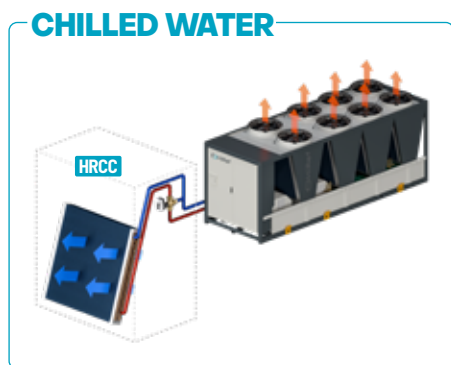

- Advanced programmable microprocessor control with LCD display
- Humidity control through dehumidification and humidification (optional)
- Fan speed modulation based on thermal load (constant  $\Delta T$ )
- Air filter class G3 as standard. Air Filters G4, M5, F7 (optional)
- Double power supply with automatic switch (optional)
- Constant-flow (airflow control) or constant available overpressure ( $\Delta P$  control) ventilation modulation (optional)
- Instant reading of water flow rate, water inlet and outlet temperatures, or supplied cooling capacity (optional)

In-Rack or In-Row configuration.

### IN RACK:

Configuration that generates a closed circuit between rack cooler and rack cabinet. The air can be drawn in and delivered from the right, left or both directions.

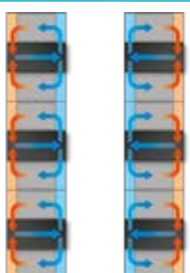

### IN ROW:

Configuration in which cold air is released into the "cold aisle" to each rack cabinet, and hot air from the surrounding environment is drawn in by the rack cooler. The air can be delivered from the front, right and left.

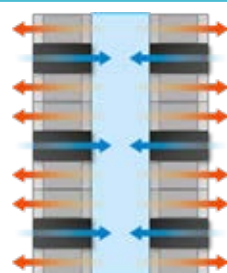



### Ventilation EC

EC PLUG fans, standard throughout the range, are adjustable using different logics: flow rate, overpressure, constant  $\Delta P$  and  $\Delta T$ . Their accurate adjustment allows an efficient use of power for ventilation and a consequent **reduction of the system's PUE**. Extended range speed adjustment is carried out via Modbus protocol. The "emergency speed" function allows for fan operation **even in the event of microprocessor malfunctions**.



### Hot swappable fans

In order to minimize machine shutdown, a **failed fan can be replaced without turning off the unit**, thanks to the use of the protective basket and connectors for the power and control section. Fan replacement thus becomes a routine maintenance operation.



### Safety in the server room

All models in the range feature heat exchange coils with hydrophilic coating. This special coating - together with adequate adjustment of air through-flow speeds - **helps condensate collection during the dehumidification process, preventing any dripping on the inside and outside of the unit**.



### Sliding control panel

For 300 mm wide structures, the electrical panel is designed to take up **as little space as possible without interfering with air distribution over the whole working height of the unit**. A "sliding drawer" structure has been used, making access possible during commissioning and extraordinary maintenance operations. This configuration also prevents tangling of the wiring.

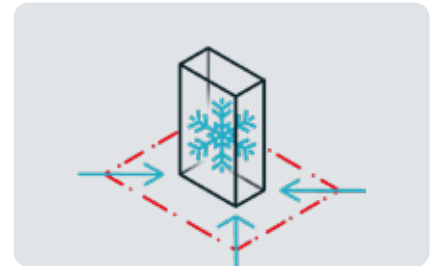

### High power density

The internal design and the special component layout allows for an evaporating coil **with an extensive heat exchange surface area**. The unit footprint is still small, **ensuring optimal use of space in the server room**.

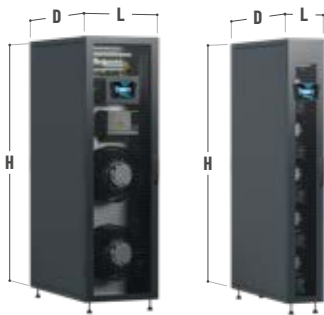

HRCC		0200	0250	0450	0510
<b>Air temperature 30°C - 35% / Water temperature In 10°C Out 15°C</b>					
Cooling capacity	kW	20.1	27.7	46.2	57
EER		43.54	38.35	31.1	37.27
SHR		1	1	1	1
<b>Air temperature 35°C - 30% / Water temperature In 15°C Out 20°C</b>					
Cooling capacity	kW	20.2	27.8	46.4	57.2
EER		43.69	38.44	31.21	37.37
SHR		1	1	1	1
Rated air flow	m <sup>3</sup> /h	4000	5300	9000	11000
Total fan absorbed power	kW	0.5	0.7	1.5	
Power supply	V/ph/Hz	230/1/50		400/3+N/50	
Lp @ nominal rpm; dist.=2m Q=2	db(A)	62	65	70	67
Dimensions [LxHxD]	mm	300x2000x1200		600x2000x1200	

Also available with 60 Hz power supply.

# MRAC CW/DX

MINI RACK COOLER  
FOR HIGH DENSITY SYSTEM

3-5 kW

 <p>MULTI-PROTOCOL COMMUNICATION INTERFACE</p>	 <p>EC RADIAL FANS</p>	 <p>INVERTER DRIVEN COMPRESSORS</p>
---	---	--



The units in the MRAC family offer an ideal solution for cooling 19" racks, which require **precise internal temperature control and 24/7 operation**. In split execution, with R410A refrigerant external condensing unit, the range extends from 3.6 to 7.9 kW. The CW version, with chilled water, reaches 4.5 kW. The MRAC unit is controlled by a **dedicated software**, developed within HiRef, allowing a LAN connection for **up to 8 units** and interfacing with an automatic door-opening system in the event of an **alarm**.

- Coil with highly efficient hydrophilic fin and aluminum frame
- A version is available for low outdoor air temperatures
- Compressor with brushless inverter technology available for 7 kW version
- Condensate drain pan made from stainless steel AISI 430
- Electrical and rapid control connections
- Completely insulated panelling
- Air filter type G3
- Refrigerant R410A

## CHILLED WATER

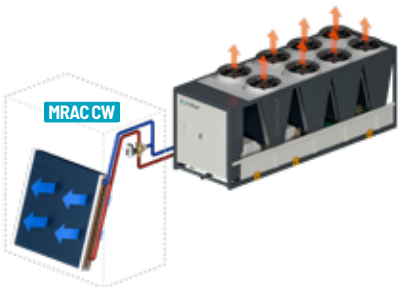

## AIR CONDENSED WITH MOTOCONDENSING

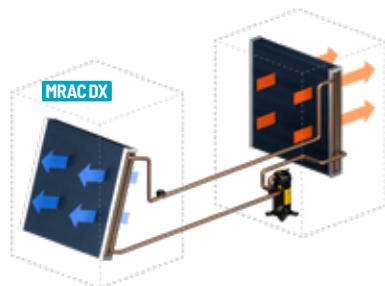

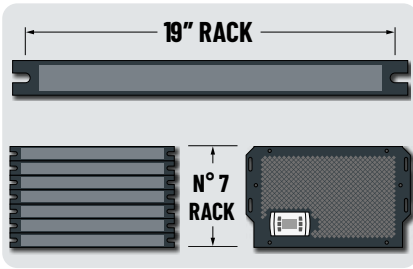

**Compactness**

MRAC has been designed to **be hidden inside the rack cabinet** and take up as little space as possible. Installable in any rack cabinet with 19" racks, it occupies the height of just 7 racks, **taking up very little space in the Data Center.**

**Maximum MRAC redundancy with the version having two external motocondensing units**

The MRAC unit with dual external motocondensing unit is available on request. This solution provides **redundancy and ensures continuity of service even in the event of failure of one of the two units.**

**Ventilation EC**

EC PLUG fans, standard on the entire range, make it possible to vary the air flow according to the thermal load. Their accurate adjustment allows an efficient use of power for ventilation and a consequent **reduction of the system's PUE.** Extended range speed adjustment is carried out via Modbus protocol. The "emergency speed" function enables the fan to move **even if the microprocessor is switched off.**

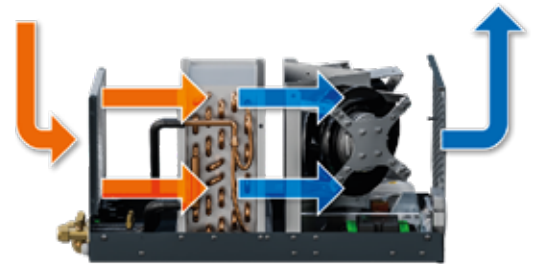

MRAC CW		0035	0070
Air temperature 30°C - 35% / Water temperature In 10°C Out 15°C			
Cooling capacity	kW	3.4	4.5
EER		17	22.5
SHR		1	1
Air temperature 35°C - 30% / Water temperature In 15°C Out 20°C			
Cooling capacity	kW	3.5	4.5
EER		17.5	22.5
SHR		1	1
Rated airflow capacity	m³/h	915	
Total fan absorbed power	kW	0.2	
Power supply	V/ph/Hz	230/1/50	
Lp @ nominal rpm; dist.=2m Q=2	db(A)	61	61
Dimensions [LxHxD]	mm	485x300x600	

Also available with 60 Hz power supply.

MRAC DX		0035	035B	0070	0070 (INVERTER)
R410A - Indoor air 30°C - 35% / Outdoor air 35°C					
Cooling capacity	kW	4	3.8	7.2	7.3
Total absorbed power	kW	1.3	1.4	2.6	2.6
EER		3.7	3.55	3.55	3.92
SHR		0.96	0.9	0.93	0.91
R410A - Indoor air 35°C - 30% / Outdoor air 35°C					
Cooling capacity	kW	4.3	4.1	7.7	7.8
Total absorbed power	kW	1.4	1.4	2.6	2.6
EER		3.98	3.75	3.75	4.17
SHR		1	0.92	0.94	0.94
Rated air flow indoor unit	m³/h	915		1330	
Rated air flow outdoor unit	m³/h		2050	3350	5100
Power supply indoor unit	V/ph/Hz	230/1/50	230/1/50	230/1/50	230/1/50
Power supply outdoor unit	V/ph/Hz	230/1/50	230/1/50	230/1/50	230/1/50
Dimensions indoor unit [LxHxD]	mm			485x300x600	
Dimension outdoor unit [LxHxD]	mm	624x541x410		1003x655x525	1305x648x495

Performance data for size 035B relating to operation with only one motocondensing unit. | Total absorbed power relating to indoor unit and motocondensing unit. | Also available with 60 Hz power supply.

# RDC

## REAR DOOR COOLING FOR HIGH DENSITY HYPERSCALE DATA CENTER

25-61 kW



**Rear Door** solutions are cooling systems designed to reduce the temperatures generated directly at the rear of the racks, where the heat produced by the servers is most intense. **Rear Door solutions can be active**, featuring fans to increase air flow, **or passive**, relying solely on natural air flow. In this way, they not only significantly lower the temperature but also **improve the overall energy efficiency of the data center.**

- Dual power supply (optional)
- Up to 61 kW of cooling capacity
- Adaptable for every rack dimension/brand
- Passive solution without fans: no noise, no additional power consumption, low maintenance
- Active solution with fans for higher dissipation capacity
- Water connection from top/bottom
- Integrated microprocessor and remote monitoring
- Reduced foot print
- Pressure-independent control valve / energy valve





**Simplified standalone or complementary solution for high-density racks**

The cooling capacity required by the rack is ensured without the need for additional precision air conditioning units. **The absence of hot return air within the IT room further contributes to improving the overall system efficiency**, eliminating the need to separate hot and cold aisles and simplifying the management and configuration of the IT environment. This solution is also **easily integrated into facilities already equipped with existing precision air conditioning systems**, allowing dedicated cooling of high power density racks and preventing the formation of hot spots.



**Up to 61 kW of cooling capacity**

Equipped with an **adaptation frame** that facilitates installation on the rear of any rack, these units represent a compact solution that **does not result in any reduction of usable space within the IT room**. The unit depth is 420 mm.



**180° door opening**

The 180° door opening ensures **full accessibility** to the internal rack components from the rear.



**EC Fans**

PLUG EC fans, supplied as standard across the entire range, are characterized by **precise control** that enables **efficient use of the electrical energy** required for ventilation, significantly contributing to the reduction of the overall system PUE.

**CHILLED WATER**

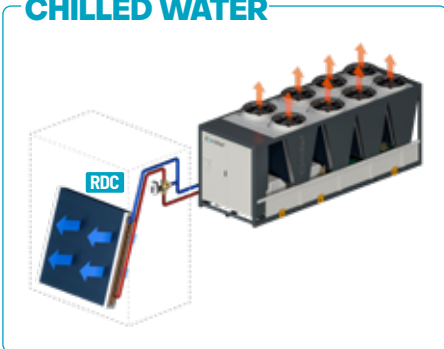

RDC	64	84	
<b>Server air outlet 35°C 30%, inlet water temperature 15°C</b>			
Cooling capacity	kW	24.9	40.7
EER		15.6	25.4
SHR		1	1
Room temperature	°C	24.3	23.3
<b>Server air outlet 40°C 25%, inlet water temperature 15°C</b>			
Cooling capacity	kW	31.1	50.7
EER		19.4	31.7
SHR		1	1
Room temperature	°C	26.2	25
<b>Server air outlet 45°C 20%, inlet water temperature 15°C</b>			
Cooling capacity	kW	37.1	60.6
EER		23.2	37.9
SHR		1	1
Room temperature	°C	28.2	26.7
Rated air flow	m <sup>3</sup> /h	6800	10500
Water flow	l/h	2000	4000
Fans power consumption	kW	1.6	1.6
Power supply	V/ph/Hz	230/1/50	
Dimensions [LxHxD]	mm	600x2000x420	800x2000x420

Also available with 60 Hz power supply.



# HYBRID ROOMS: the combined solution between air and water cooling for data centers

In recent years, several technologically advanced solutions have emerged to meet the **new cooling needs** of data centers, server rooms, and IT rooms. **Liquid cooling systems**, in particular, have become an increasingly sophisticated choice for air conditioning, both in the **direct-to-chip** versions (where only certain components like chipsets and GPUs are cooled) and **immersion cooling** (where all server components are submerged in a dielectric liquid).

It is true that liquid cooling systems provide **greater thermal efficiency** and **reduce energy consumption**, even as computing needs increase and more powerful microprocessors are used. However, these are not definitive solutions: around 10-20% of the heat is still released into the air. For this reason, **'hybrid' solutions are now being designed and developed**, incorporating perfectly coordinated **liquid and air cooling systems** for the racks.

Recent developments in IT therefore **require advanced heat management solutions**. Liquid cooling offers an effective response to this challenge, providing significant advantages over traditional air cooling systems. Its **superior efficiency in 'capturing' and dispersing heat** from critical production areas within the server (such as the CPU and GPU) not only ensures the **optimal operation of data centers** but also reduces the amount of energy needed to maintain the optimal temperature of the coolant (which is higher than that of the chilled water in air cooling systems).

**Liquid cooling is one of the emerging solutions for thermal management in data centers**, which could help address the increasing power of modern processors. The use of a coolant to absorb, transfer, and dissipate the heat generated by high-power electronic components offers **several advantages** over traditional air cooling systems:

- **greater thermal efficiency**, with more efficient heat transfer;
- **reduced energy consumption**, as the higher efficiency of liquids in transporting heat requires less energy to maintain the optimal temperature;
- **lower environmental impact**, due to a smaller thermal and energy footprint.

**However, liquid cooling cannot be the sole solution.** A portion of the heat generated by data centers (about 10-20%) is still released into the air. Therefore, conventional cooling systems will still need to be utilized, prompting a reconsideration of data center room design.

Among the new solutions are **Coolant Distribution Units (CDUs)**, which efficiently distribute the coolant while maintaining it within optimal temperature ranges to ensure the longevity of the cooling system. At the same time, HiRef is developing **Rear Door solutions**, an active or passive air conditioning system to be applied to the rear of the rack.

Additionally, in the hybrid room of the future, another key element will be the **HiNode**, a device that enables interfacing with and **monitoring all components and devices** of the cooling system.

A combined solution, therefore, must be able to harness the **synergy between air and water cooling systems** to minimize inefficiencies and ensure maximum operational continuity for data centers.





## Hybrid Solution 1



### TRF Displacement

The new chilled water air conditioners of the TRF CW series are particularly suitable for IT facilities where **temperature and air flow need to be continuously monitored**. The components of the TRF CW unit offer the most efficient solution for **Data Center cooling**, ensuring **reliability, precise control of thermo-hygrometric conditions** and the **flexibility** to adapt to different working conditions.



### NRG F Displacement

NRG F units are water-condensed perimeter mounted cabinets that are able to exploit **indirect water-based Free-Cooling**. The NRG F Series uses Dry Cooler water as both a source for free-cooling and a heat exchanger for condensing the cooling circuit. NRG F "monobloc" units inside which the **entire cooling circuit is concentrated**. Cooling is via a **plate exchanger made of stainless steel 304**.

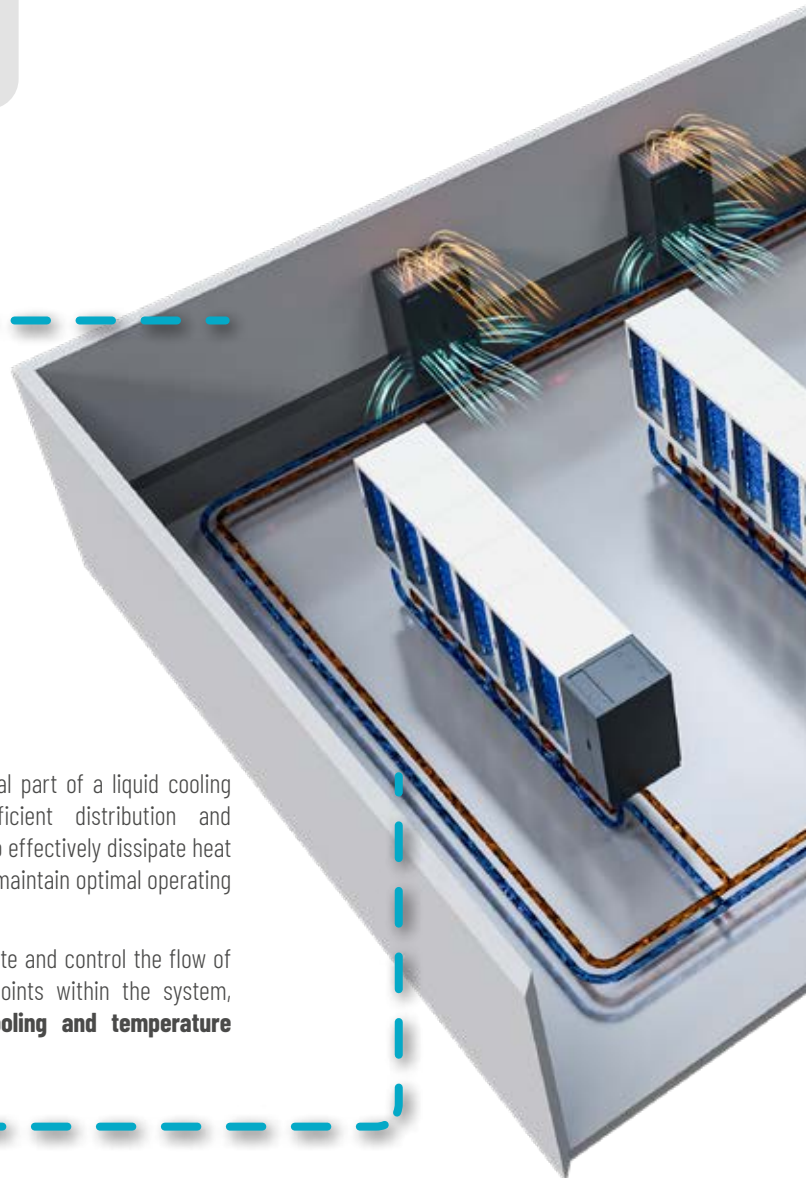

### CDU

The CDU is an essential part of a liquid cooling system, enabling efficient distribution and circulation of coolant to effectively dissipate heat from components and maintain optimal operating temperatures.

It is designed to regulate and control the flow of coolant to different points within the system, ensuring **efficient cooling and temperature management**.

meter-  
bit the **effect**  
g. The F  
cooling  
change fluid  
F units are  
**e cooling**  
**brazed**  
**steel AISI**

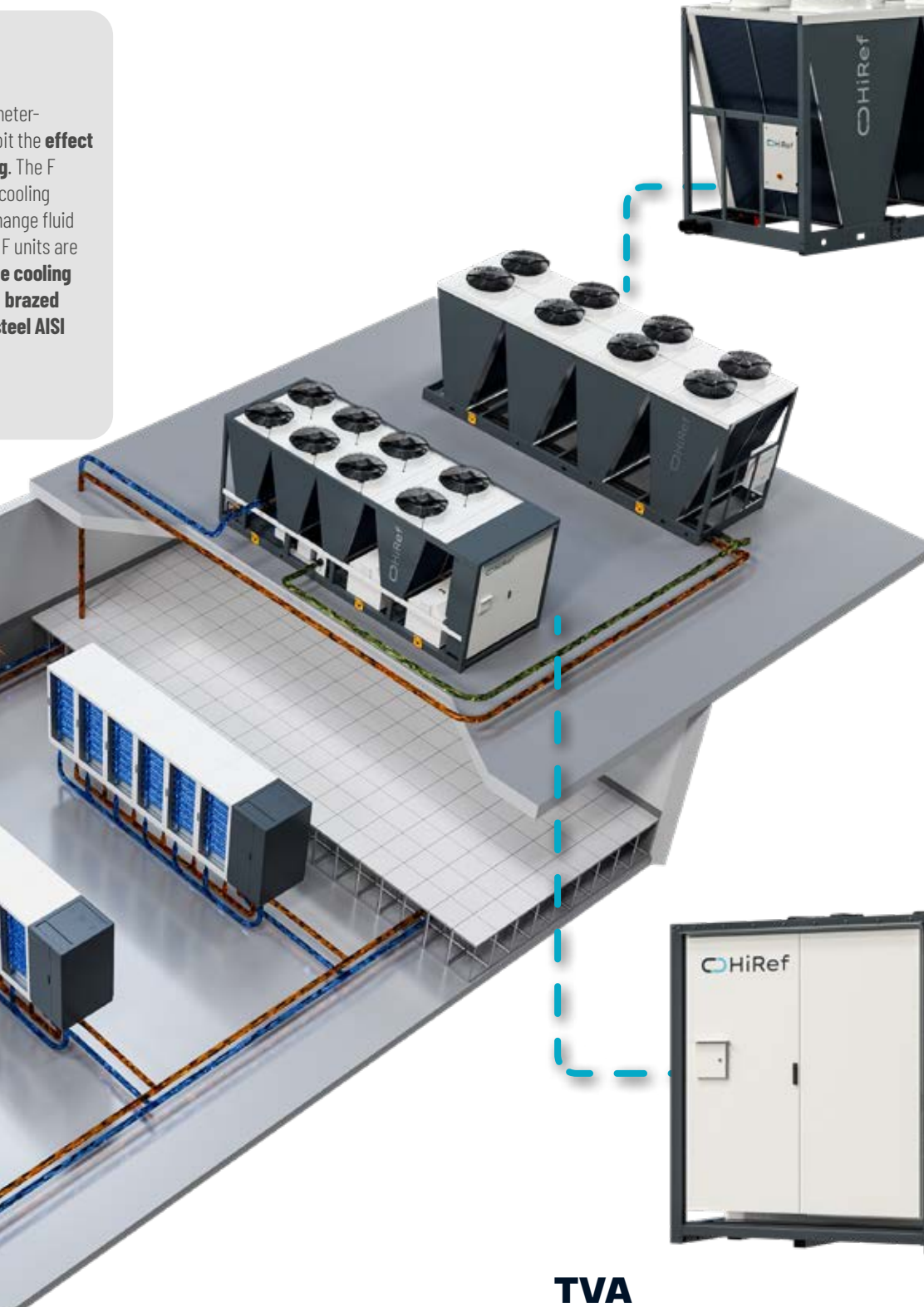

## Dry Cooler

HiRef Dry Coolers are outdoor units that can be combined with water-condensed indoor units such as cabinets in the W - F - K series. HiRef offers a **wide range** of Dry Coolers suitable for working with a **water-glycol mixture up to 60%**. They are made with frame in aluminium alloy and galvanized sheet steel that ensures **corrosion resistance, copper pipe protection and solidity**. The external panels are made of galvanized sheet metal finished with **corrosion- and UV-resistant polyester paint**.



## TVA

TVA is the new range of air cooled chillers for energy-efficient and environment-friendly processes. Low environmental impact has been achieved by using **new HFO refrigerants** with low Global Warming Potential (GWP), while **higher efficiency/footprint ratios** are reached thanks to the special V-configuration of the heat exchange coils and their sizing, **the largest among the chillers currently available on the market**. The Free-Cooling version - where heat exchange surface areas are double the market average - **ensure outstanding performance**. The high thermodynamic efficiency with low Total Equivalent Warming Impact (TEWI) is combined with a special focus on maintainability and **easy accessibility of the compressors contained in the removable HiRail module** which reduces noise emissions.

## Hybrid Solution 2



### FanWall HBCV

FanWall range is perfectly suited for hybrid applications, offering the possibility of operating with a single external dissipation system. Our chilled water FanWall HBCV series air conditioners are designed for technological environments where a **compact footprint is a requirement - without any impact on these units' cooling output capacity.** An in-depth CFD (computational fluid dynamics) analysis has allowed every last constructive detail to be designed so as **to minimise internal airflow pressure drops and, therefore, fan power consumption.** At the same time, the large surface of the finned pack exchanger **minimises the approach temperatures between inlet air and outlet water, maximising system efficiency.**

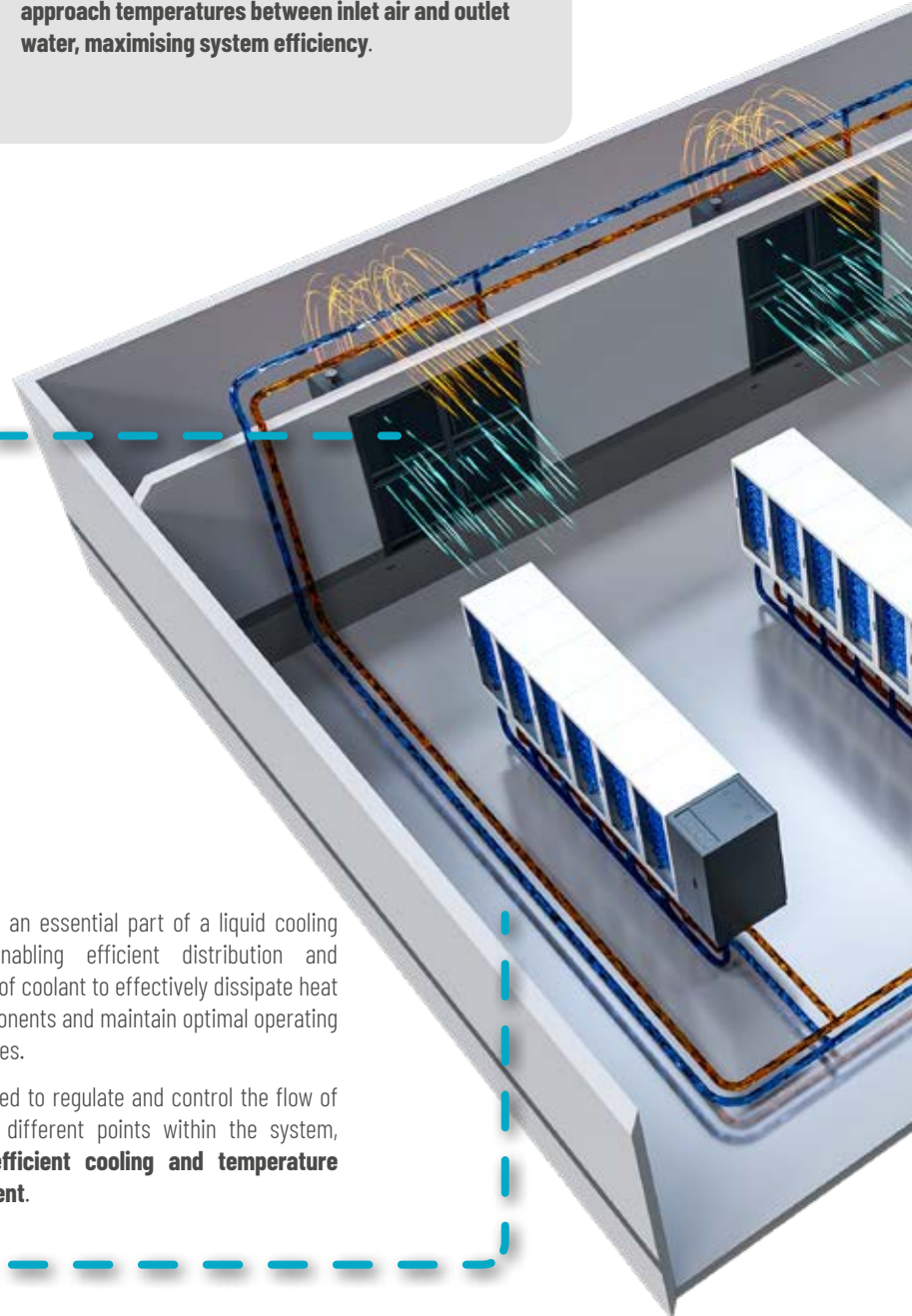

### CDU

The CDU is an essential part of a liquid cooling system, enabling efficient distribution and circulation of coolant to effectively dissipate heat from components and maintain optimal operating temperatures.

It is designed to regulate and control the flow of coolant to different points within the system, ensuring **efficient cooling and temperature management.**

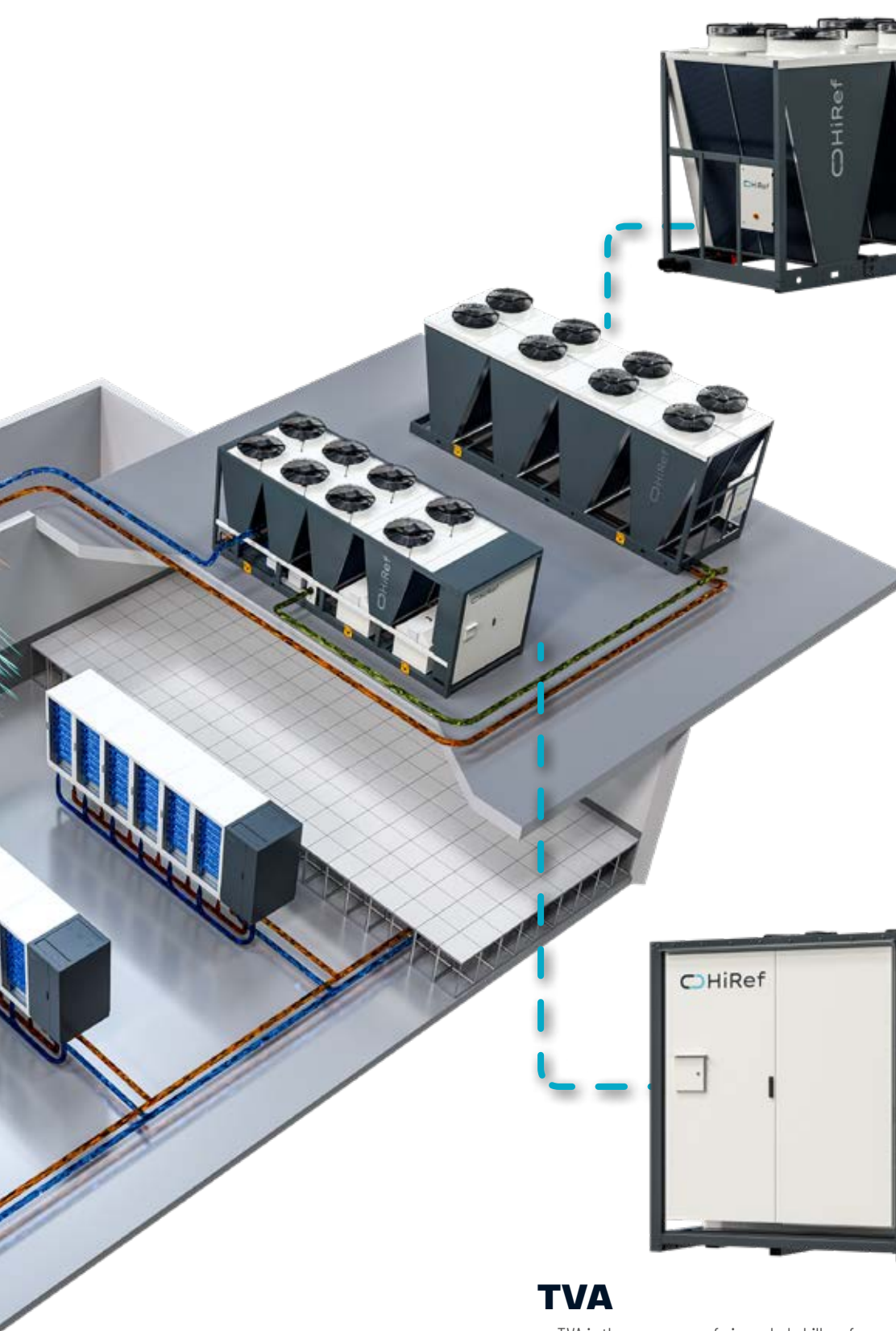

### Dry Cooler

HiRef Dry Coolers are outdoor units that can be combined with water-condensed indoor units such as cabinets in the W - F - K series. HiRef offers a **wide range** of Dry Coolers suitable for working with a **water-glycol mixture up to 60%**. They are made with frame in aluminium alloy and galvanized sheet steel that ensures **corrosion resistance, copper pipe protection and solidity**. The external panels are made of galvanized sheet metal finished with **corrosion- and UV-resistant polyester paint**.



### TVA

TVA is the new range of air cooled chillers for energy-efficient and environment-friendly processes. Low environmental impact has been achieved by using **new HFO refrigerants** with low Global Warming Potential (GWP), while **higher efficiency/footprint ratios** are reached thanks to the special V-configuration of the heat exchange coils and their sizing, **the largest among the chillers currently available on the market**. The Free-Cooling version - where heat exchange surface areas are double the market average - **ensure outstanding performance**. The high thermodynamic efficiency with low Total Equivalent Warming Impact (TEWI) is combined with a special focus on maintainability and **easy accessibility of the compressors contained in the removable HiRail** module which reduces noise emissions.

## Hybrid Solution 3



### Rear Door Cooling

The rear door is a cooling system used in data centers to dissipate the heat generated by servers **directly at the back of the rack cabinets**.

The operation involves the hot air expelled by the servers passing through the rear door, where it is cooled before being released into the environment. This significantly reduces the air temperature inside the data center, **improving energy efficiency and reducing the need for traditional cooling** at the environmental air conditioning level.

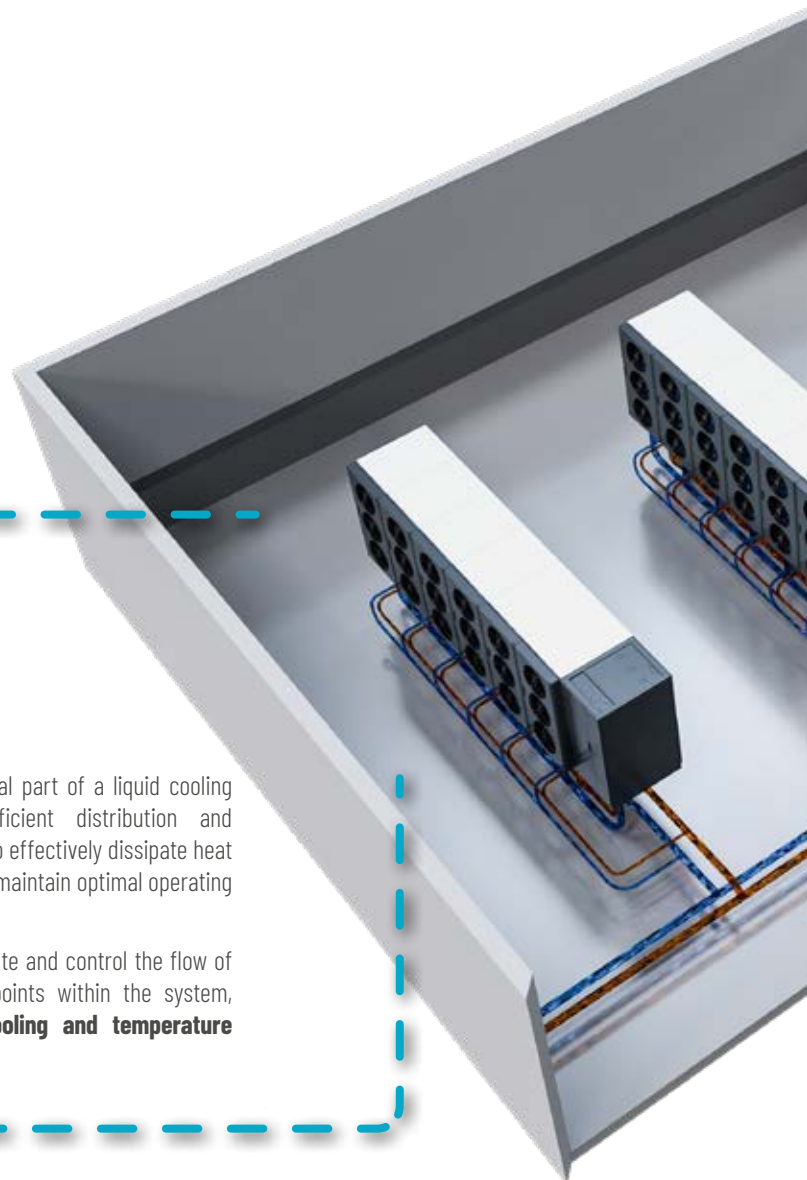

### CDU

The CDU is an essential part of a liquid cooling system, enabling efficient distribution and circulation of coolant to effectively dissipate heat from components and maintain optimal operating temperatures.

It is designed to regulate and control the flow of coolant to different points within the system, ensuring **efficient cooling and temperature management**.

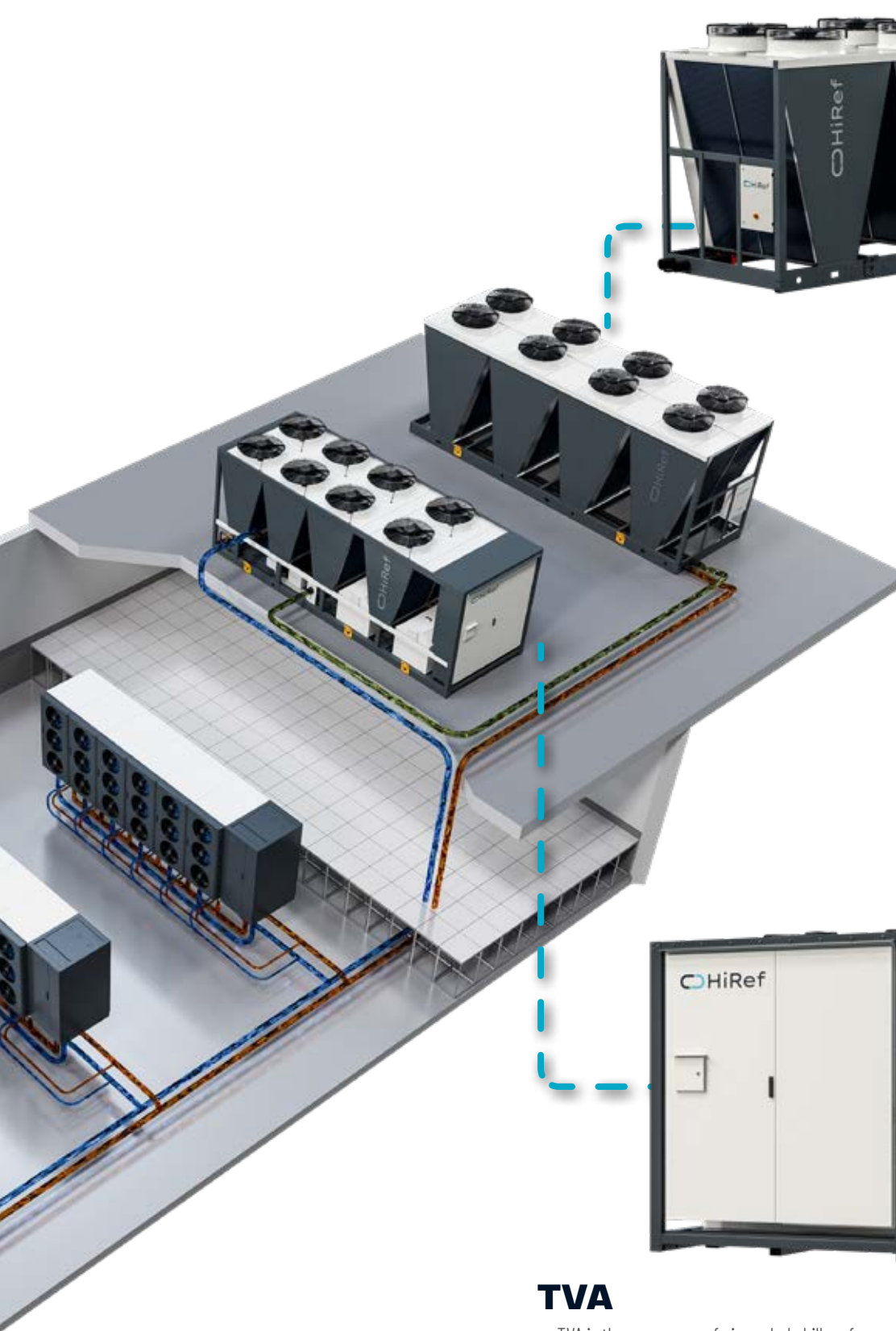

## Dry Cooler

HiRef Dry Coolers are outdoor units that can be combined with water-condensed indoor units such as cabinets in the W - F - K series. HiRef offers a **wide range** of Dry Coolers suitable for working with a **water-glycol mixture up to 60%**. They are made with frame in aluminium alloy and galvanized sheet steel that ensures **corrosion resistance, copper pipe protection and solidity**. The external panels are made of galvanized sheet metal finished with **corrosion- and UV-resistant polyester paint**.



## TVA

TVA is the new range of air cooled chillers for energy-efficient and environment-friendly processes. Low environmental impact has been achieved by using **new HFO refrigerants** with low Global Warming Potential (GWP), while **higher efficiency/footprint ratios** are reached thanks to the special V-configuration of the heat exchange coils and their sizing, **the largest among the chillers currently available on the market**. The Free-Cooling version - where heat exchange surface areas are double the market average - **ensure outstanding performance**. The high thermodynamic efficiency with low Total Equivalent Warming Impact (TEWI) is combined with a special focus on maintainability and **easy accessibility of the compressors contained in the removable HiRail module** which reduces noise emissions.









# LIQUID COOLING

# CDU

## COOLANT DISTRIBUTION UNIT FOR HIGH DENSITY HYPERSCALE DATA CENTER



 MULTI-PROTOCOL COMMUNICATION INTERFACE	 CORROSION RESISTANT MATERIAL	 PLATE HEAT EXCHANGER
 $\Delta T$ PRECISION CONTROL	 PRESSURE INDEPENDENT VALVE (PICV)	 MODULATING PUMPS

The **CDU** is a key component of a liquid cooling system, enabling the distribution and circulation of the coolant to effectively dissipate heat from components and maintain optimal operating temperatures. It is designed to regulate and control the flow of PG25 to various points within the system, **ensuring efficient cooling and optimal temperature management.**

- Pumps with integrated inverter, N+1 redundant
- High efficiency plates heat exchangers for low  $\Delta T$
- Complete separation of primary and secondary hydronic circuits
- Secondary circuit entirely made of stainless steel with air venting capability
- Large dual redundant secondary filters with configurable filtration degree (25 $\mu$ , 50 $\mu$ )
- Integrated expansion vessels on secondary side
- 15" Colour touchscreen controller
- Communication via Modbus RTU (RS485) and TCP/IP protocols
- Temperature and humidity sensors for room control



### Redundant inverter driven pumps

The CDU unit is equipped with 3 modulating pumps with integrated inverter and IE5 motor. The pump design allows to reach **high level of flexibility and redundancy**: normal mode, all 3 pumps work together in parallel with a large modulation range; in emergency mode, when one pump is on fault, two pumps can deliver 85% of the total water flow allowing the system to continue working. The IE5 motor meets **the highest efficiency requirements while reducing the pumping costs.**

### Variable connections

The connections position both on primary and secondary side can be configured on top or on bottom sides of the unit, in order **to meet the installation site requirements, also in case of retrofit installations.** The unit is provided in addition with a stainless steel basin that protects from fluid drops in case of losses.



**Filtered Data Center Side**

The CDU is equipped with filters featuring a configurable filtration rating of 25/50 µm, which remove impurities from the fluid, preventing clogging and damage to other system components. These filters can be replaced while the CDU is in operation, **without the need to shut down the system. By keeping the fluid clean, the CDU helps extend the service life of the entire cooling system.**



**Stainless steel brazed plate heat exchangers**

Stainless steel heat exchangers ensure the better solution considering efficiency, durability and compactness. This type of heat exchanger allows the **use of different type of fluids, from glycol mixtures to non conductive fluids without reducing the reliability.**



**2-way PICV valve**

The CDU unit is equipped with an integrated 2-way PICV valve on the primary circuit, allowing modulation of the cooling capacity. The Pressure Independent Control Valve (PICV) integrates flow control and hydronic balancing, **ensuring a constant flow rate regardless of system pressure and simplifying installation.**

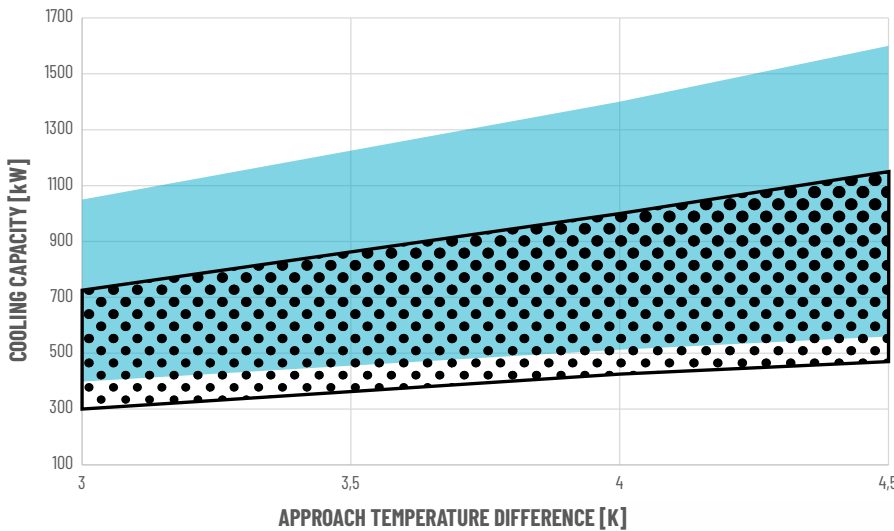

• • • • Footprint 600x1200 - Redundancy N  
 — Footprint 900x1200 - Redundancy N+N

**OPERATING CONDITIONS IN THE CHART**

- Primary: ACQUA 20°C/30°C
- Secondary: PG25 34°C/24°C



CDU		1000HB	1400HC
ATD = 4K, Primary 20°C/30°C, Secondary 24°C/34°C. Primary side fluid: water, Secondary side fluid: PG25. Available pressure at pumps: 150 kPa			
Cooling capacity	kW	1000	1400
Total absorbed power	kW	9,8	17
Primary - Heat exchanger losses	kPa	46	65
Primary - Rated flow	l/h	86000	120400
Secondary - Heat exchanger losses	kPa	54	40
Secondary - Rated flow	l/h	90300	126400
Pump redundancy	-	1	1+1
Dimensions [LxHxD]	mm	600x2000x1200	900x2000x1200





# REMOTE CONDENSER AND DRY COOLER

# HDC

## MODULAR DRY COOLER

372-1551 kW

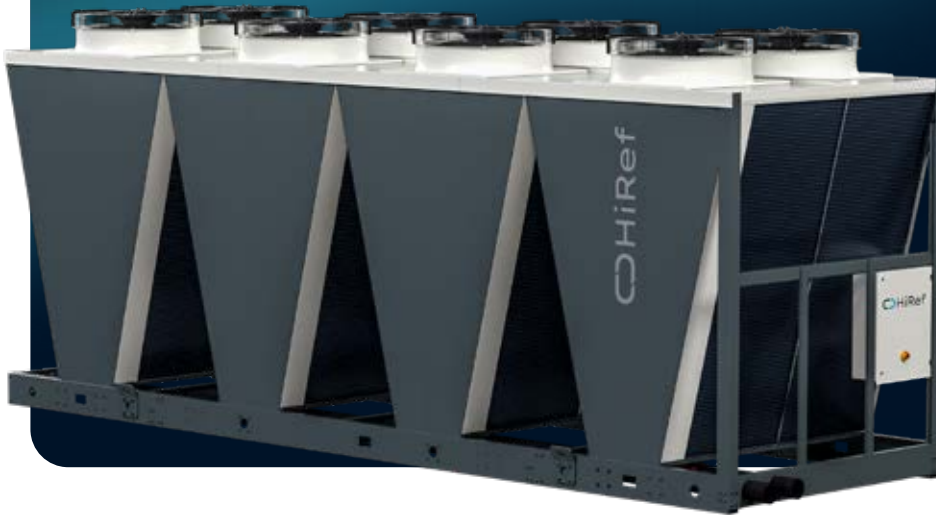

<p>MULTI-PROTOCOL COMMUNICATION INTERFACE</p>	<p>CORROSION RESISTANT MATERIAL</p>
<p>PATENTED SOLUTION</p>	<p>VARIABLE GEOMETRY COIL (FLEXY)</p>

The Dry Cooler range from HiRef has been **specifically designed for data center applications**. It is ideally suited for use with liquid cooling systems or in any situation where free cooling can be utilized. HiRef Dry Coolers are outdoor units that can be combined with water-condensed indoor units such as cabinets in the W - F - K series. HiRef offers a **wide range** of Dry Coolers suitable for working with a **water-glycol mixture up to 60%**. They are made with frame in galvanized sheet steel that ensures **corrosion resistance, copper pipe protection and solidity**. The external panels are made of galvanized sheet metal finished with **corrosion and UV-resistant polyester paint**.

- Power supply 400V three phase
- HiRef Dry Coolers are outdoor units that can be combined with indoor water-cooled condensing units, such as the W - F - K series cabinets or the XSB and XVA chillers
- Modular solution "grows with the business"
- Larger heat exchangers
- Reduced foot print
- Water circuit optimized for variable flow rates
- Regulation on board the unit with integrated ATS
- Modbus interface for connection to CMS
- EC Fans





**Finned coil**

The finned-coil heat exchangers are made with copper tubes and wavy or corrugated aluminium fins. The standard spacing between the fins is 2 mm, **offering high heat exchange efficiency without affecting the ease of routine cleaning.**

**Modular solution**

HiRef's dry coolers have been designed with the concept of connecting an increasing number of heat exchangers to the master dry cooler to accommodate the growing power demand. This expansion is possible **without the need to modify the customer-side piping**, simply by planning for the additional space required for future expansions during the design phase.



**Silent operation**

The Dry Coolers are also available in **low noise emission versions**, ideal in areas where a **high level of acoustic comfort** must be maintained.



**Customization**

The units can be customized on request to meet the customer's design needs. Among the various options:

- **special treatment for the finned-coil exchanger**, including epoxy treatment, offering good resistance to corrosive environments, or copper fins for installation in marine environments;
- **increased fin spacing** to reduce soiling and facilitate cleaning in sandy environments.



HDC		04H057E	06H057E	08H057E
<b>Air temperature 10°C / Ethylene glycol 30% / Fluid temperatures 30/20°C</b>				
<b>Cooling capacity</b>	kW	775.6	1183.4	1551.2
<b>Fluid flow</b>	l/h	72000	108000	144000
<b>Air temperature 35°C / Ethylene glycol 30% / Fluid temperatures 45/40°C</b>				
<b>Cooling capacity</b>	kW	372.4	558.6	744.8
<b>Fluid flow</b>	l/h	69200	103800	138400
<b>Lp @ nominal rpm; dist.=2m @=2</b>	db(A)	89	91	92
<b>Power supply</b>	V/ph/Hz		400/3+N/50	
<b>Dimensions [LxHxD]</b>	mm	3750x3135x2250	5625x3135x2250	7500x3135x2250

# REMOTE CONDENSERS

HiRef remote condensers are outdoor units that can be combined with indoor air-cooled units such as A – D series cabinets and NRCD rack coolers. HiRef offers a **wide range of condensers**, suitable for use with refrigerants R410A, R513A, R454B, R407C. When paired with dual-circuit units, the condensers are available with a single refrigeration circuit – ensuring **maximum system reliability and redundancy** – or with a dual refrigeration circuit, **reducing installation space and costs**. The models are built with an aluminum alloy frame and galvanized sheet metal: an ideal solution to ensure **high corrosion resistance, protection of copper pipes**, and durability. The external panels are made of **galvanized sheet metal with polyester coating resistant to corrosion and UV rays**.

- Power supply 230V single phase or 400V three phase
- Power supply from HiRef indoor unit (standard) or stand alone (on request)

## Finned coil

The finned-coil heat exchangers are made with copper tubes and, depending on the model, wavy or corrugated aluminium fins. The standard spacing between the fins is 1.8 – 2 – 2.1 mm, depending on the model, **offering high heat exchange efficiency without affecting the ease of routine cleaning**.

## Silent operation

The remote condensers are also available in **low noise emission versions**, ideal in areas where **a high level of acoustic comfort must be maintained**.

## Versatility

As an alternative to vertical installation with horizontal air flow, as standard, **horizontal installation with upward air flow is possible**, with the use of a leg kit that can be ordered separately.



## Customization

The units can be customized on request to meet the customer's design needs. Among the various options:

- **special treatment for the finned-coil exchanger**, including epoxy treatment, offering good resistance to corrosive environments, or copper fins for installation in marine environments;
- **increased fin spacing** to reduce soiling and facilitate cleaning in sandy environments;
- **special ductable condensers** for installation in closed places.

## Efficiency

Depending on the model, the units mount axial fans with diameters of 350 – 450 – 500 – 630 mm. The fans, with 4 or 6 poles, can be adjusted using a speed regulator from the indoor unit or mounted on the machine. The units are also available with high efficiency EC fans **for low operating consumption and reliable control of the condensing temperature thanks to electronic speed regulation**.

# DRY COOLER

HiRef Dry Coolers are outdoor units that can be combined with water-condensed indoor units such as cabinets in the W - F - K series. HiRef offers **a wide range** of Dry Coolers suitable for working with a **water-glycol mixture up to 60%**. They are made with frame in aluminium alloy and galvanized sheet steel that ensures **corrosion resistance, copper pipe protection and solidity**. The external panels are made of galvanized sheet metal finished with **corrosion- and UV-resistant polyester paint**.

- Power supply 230V single phase or 400V three phase
- Power supply from HiRef indoor unit (standard) or stand alone (on request)

## Finned coil

The finned-coil heat exchangers are made with copper tubes and, depending on the model, wavy or corrugated aluminium fins. The standard spacing between the fins is 2 mm, **offering high heat exchange efficiency without affecting the ease of routine cleaning**.

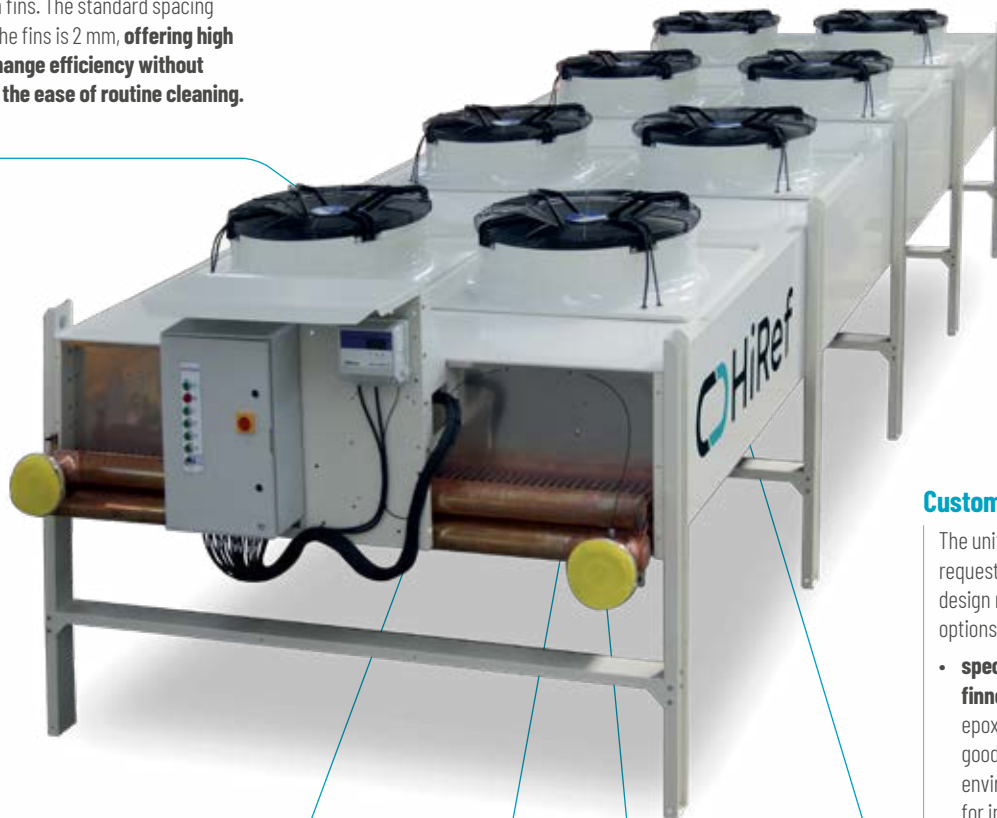

## Customization

The units can be customized on request to meet the customer's design needs. Among the various options:

- **special treatment for the finned-coil exchanger**, including epoxy treatment, offering good resistance to corrosive environments, or copper fins for installation in marine environments;
- **increased fin spacing** to reduce soiling and facilitate cleaning in sandy environments.

## Versatility

As an alternative to vertical installation with horizontal air flow, as standard, **horizontal installation with upward air flow is possible**, with the use of a leg kit that can be ordered separately.

## Silent operation

The Dry Coolers are also available in **low noise emission versions**, ideal in areas where a **high level of acoustic comfort must be maintained**.

## Efficiency

Depending on the model, the units mount axial fans with diameters of 350 - 500 - 630 - 800 mm. The fans, with 6 or 8 poles, can be adjusted using a speed regulator from the indoor unit or mounted on the machine. The units are also available with high efficiency EC fans for **low operating consumption and reliable control of the condensing temperature thanks to electronic speed regulation**.







# LIQUID CHILLERS

# TSE

## CHILLERS WITH REMOTE CONDENSER WITH SCROLL COMPRESSORS

43-433 kW



 MULTI-PROTOCOL COMMUNICATION INTERFACE	 PLATE HEAT EXCHANGER	 SCROLL COMPRESSORS
 CORROSION RESISTANT MATERIAL	 A2L READY	 LOW GWP REFRIGERANT

TSE is the HiRef range of liquid chillers with remote condenser and Scroll compressors. These units are available with different refrigerating set-ups (Efficiency Packs), numerous power ratings and two different noise emission set-ups, making them **particularly versatile for a number of system engineering applications**. Sizing, the choice of individual components and control of auxiliary units (circulation pumps, remote condenser fans) all aim to **reduce energy consumption and increase energy savings throughout the system**. The configurations available for the refrigeration circuit are:

**EFFICIENCY PACK 1:** Dual compressor on dual circuit for high system redundancy. For units from 43 to 177 kW.

**EFFICIENCY PACK 2:** Dual compressor (tandem) on single circuit for greater efficiency at partial loads. For units from 43 to 177 kW.

**EFFICIENCY PACK 4:** Four compressors (dual tandem) on dual circuit, for a redundant system that is also efficient with low loads. For units from 146 to 433 kW.

Sizes above 433 kW are always of the dual refrigerating circuit type with five or six Scroll compressors.

- Refrigerant R410A: Available on request with R454B
- Electronic expansion valve
- Optional Vic-Taulic hydraulic couplings
- Remote condenser fan management for air flow modulation
- External pump control according to constant T or constant ΔT logic
- Partial heat recovery (desuperheater) (optional)
- Oil recovery kit for refrigeration lines up to 50 m long

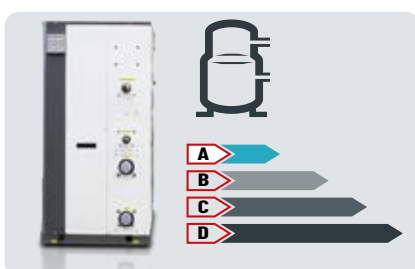

### Maximum efficiency at partial loads

The TSE range features a multi-Scroll solution also on single circuits, electronically controlled expansion valves and the option of managing the circulation pumps and remote condenser fans via onboard software: all these features help **achieve high standards of energy efficiency, particularly at partial loads**.

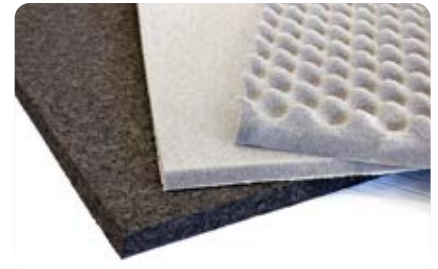

**Reduced footprint**

The carefully arranged component layout, together with compact plate heat exchangers and the Scroll compressors, gives the machine a **compact configuration and makes it adaptable to any installation area**. Sizes with **EFFICIENCY PACK 1 and 2** also have a width compatible with that of most commercially available doors, **making transport and installation easier**.

**Efficiency and reliability in line with system requirements**

The main strength of the TSE range is given by **its numerous configurations available for the refrigeration circuit**, which, depending on the size of the machine and system construction requirements (redundancy and/or efficiency at reduced load), can be available in the form of different **EFFICIENCY PACKS**. The management of the oil return through integrated software logic also helps **to increase the reliability of the compressors** - and consequently - of the unit.

**Attention to detail and to low noise requirements**

Scroll compressors, which are the main noise source in the unit, are fitted on rubber feet; these dampen vibration and therefore **attenuate the noise transmitted to the various system parts**. On request, the compressor enclosure can be lined with special sound absorbing material and the compressors can be enclosed in special insulating sheaths **to reduce airborne noise emission**.



TSE	041 CS	042 CS	051 CS	052 CS	061 CS	062 CS	071 CS	072 CS	081 CS	082 CS	091 CS	092 CS	
<b>User water values 12/7°C, condensing temperature 50°C</b>													
Cooling capacity	kW	43.1	43.1	50.5	50.3	57.9	57.9	65.2	65.1	75.3	75.4	84.5	84.3
Total absorbed power	kW	13.2	13.2	15.5	15.5	17.5	17.5	19.5	19.5	22.4	22.4	25.2	25.2
EER		3.26	3.25	3.25	3.24	3.32	3.32	3.34	3.33	3.37	3.37	3.35	3.34
Weight	kg	372	362	432	422	442	432	452	442	472	462	512	492
Sound power [Standard]	dB(A)	76	76	78	78	78	78	79	79	79	79	81	81
Sound power [Low noise]	dB(A)	72	72	74	74	74	74	75	75	75	75	77	77
Dimensions [LxHxD]	mm	1174x1930x772											
TSE	111 CS	112 CS	131 CS	132 CS	141 CS	142 CS	144 CS	161 CS	162 CS	164 CS	181 CS	182 CS	
<b>User water values 12/7°C, condensing temperature 50°C</b>													
Cooling capacity	kW	100.2	100.1	114.4	114.1	127.3	127.3	131.2	139.7	139.4	149.8	175.1	175.1
Total absorbed power	kW	29.8	29.8	34.6	34.6	37.8	37.8	39	41.2	41.2	44.8	53.1	53.1
EER		3.36	3.36	3.31	3.3	3.37	3.37	3.37	3.39	3.39	3.34	3.3	3.3
Weight	kg	563	553	573	563	633	618	723	673	653	743	713	693
Sound power [Standard]	dB(A)	84	84	85	85	85	85	82	85	85	82	90	90
Sound power [Low noise]	dB(A)	80	80	81	81	81	81	78	81	81	78	86	86
Dimensions [LxHxD]	mm	1644x1930x772						2374x1990x877	1644x1594x772		2374x1854x877	1644x1594x772	
TSE	184 CS	204 CS	214 CS	244 CS	284 CS	314 CS	344 CS	374 CS	424 CS	484 CS			
<b>User water values 12/7°C, condensing temperature 50°C</b>													
Cooling capacity	kW	169.8	185.3	199.2	228	249.6	272	303.1	338.8	384.4	433.2		
Total absorbed power	kW	50.4	55	59.7	68.8	75.5	82.2	94	105.7	118.9	132.1		
EER		3.37	3.37	3.33	3.31	3.31	3.31	3.23	3.21	3.23	3.28		
Weight	kg	853	873	923	983	1093	1253	1293	1333	1413	1520		
Sound power [Standard]	dB(A)	84	85	86	88	88	88	91	93	94	95		
Sound power [Low noise]	dB(A)	80	81	82	84	84	84	87	89	90	91		
Dimensions [LxHxD]	mm	2374x1854x877											

Also available with 60 Hz power supply

# TVD

## AIR CONDENSED CHILLERS WITH INVERTER DRIVEN SCREW COMPRESSORS

512-1586 kW



 MULTI-PROTOCOL COMMUNICATION INTERFACE	 SCREW COMPRESSORS	 SHELL AND TUBE HEAT EXCHANGER
 FAST RESTART	 AXIAL FANS	 CORROSION RESISTANT MATERIAL
 CLASS A	 INVERTER DRIVEN COMPRESSORS	 LOW GWP REFRIGERANT

TVD is the new range of air cooled chillers for energy-efficient and environment-friendly processes. Low environmental impact has been achieved by using **new HFO refrigerants** with low Global Warming Potential (GWP), while **higher efficiency/footprint ratios** are reached thanks to the special V-configuration of the heat exchange coils and their sizing, **the largest among the chillers currently available on the market**. The Free-Cooling version - where heat exchange surface areas are double the market average - **ensure outstanding performance**. In addition to high thermodynamic efficiency with a low Total Equivalent Warming Impact (TEWI), particular attention has also been given to maintainability and **easy access to the compressors**.

- Available refrigerants: R1234ze and R515B
- Electronic expansion valve
- Capacity modulation via inverter on both compressors or on a single compressor
- Monitoring and limitation of the maximum absorbed power
- Available with single or double pumping kit in timed rotation
- Glycol-Free kit available
- EC Fans
- Dual power supply (optional)
- Active filter for harmonic distortion reduction (optional)

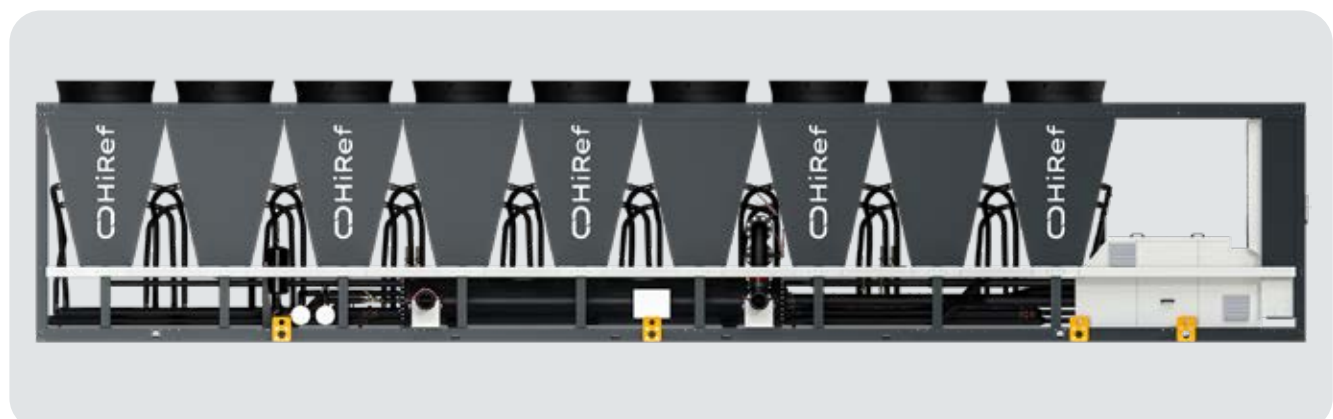



**Inverter screw compressors**

The screw compressors equipped with inverter ensure constant power modulation and high energy efficiency even at partial loads.



**Modular and efficient**

The configuration with very deep 'V' modular coils provides **an extensive heat exchange surface area and therefore excellent thermal efficiency in relation to the unit footprint.**

**New refrigerant R1234ze**

TVA air condensed chillers use **the new HFO refrigerant with low GWP** (GWPR1234ze=6 ) as part of a wider Green Technology approach. (Also available in version with R134a refrigerant and on request with R513A.)

**Harmonic distortion reduction**

Active filter for reducing voltage and current harmonic distortion THDi/v <5%.

**New concept of heat exchange**

Single pass shell and tube evaporators provide **excellent levels of thermodynamic efficiency** thanks to full heat exchange counter-flow.

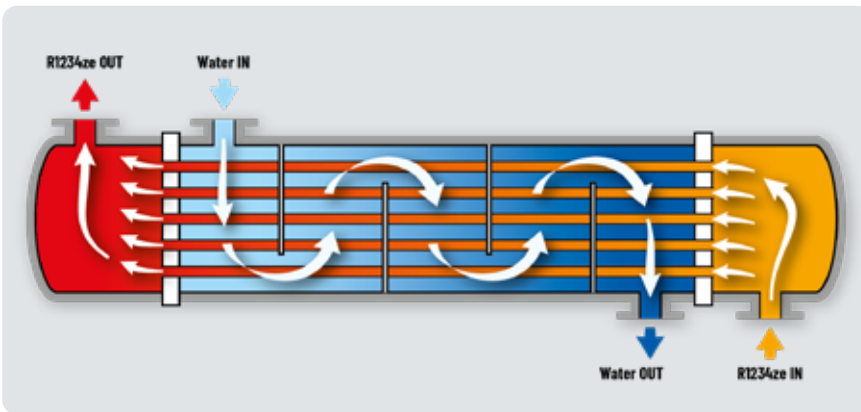

TVD	050F	074F	086F	100F	115F	130F	140F	153F	
<b>Cooling / Free Cooling: User water temperature 30/20 °C, 25% ethylene glycol, outdoor air 40 °C, 40% R.H.</b>									
Cooling capacity	kW	512	744	849	988.6	1138	1271	1382	1540
Total absorbed power	kW	146.4	217	241.7	275	305.5	359	192	426
EER		3.5	3.4	3.5	3.5	3.7	3.5	3.5	3.7
Sound power [Standard]	dB(A)	97	99	99	99	100	101	102	102
Dimensions [LxHxD]	mm	4904x2650x2255	6155x2650x2255	7405x2650x2255	8655x2650x2255	10700x2650x2255	11950x2650x2255	13500x2650x2255	
TVD	050C	074C	086C	100C	115C	130C	140C	153C	
<b>Cooling: User water temperature 30/20 °C, outdoor air 40 °C, 40% R.H.</b>									
Cooling capacity	kW	529	768	881	1022	1172	1314	1430	1586
Total absorbed power	kW	142	211	235	270	298.3	348	381	415
EER		3.72	3.6	3.7	3.7	3.9	3.7	3.7	3.8
Sound power [Standard]	dB(A)	97	99	99	99	100	101	102	102
Dimensions [LxHxD]	mm	4904x2650x2255	6155x2650x2255	7405x2650x2255	8655x2650x2255	10700x2650x2255	11950x2650x2255	13500x2650x2255	

Data declared with use of R134a refrigerant | Also available with 60 Hz power supply

# TTX

## AIR CONDENSED CHILLERS WITH OIL-FREE CENTRIFUGAL COMPRESSORS

540-2120 kW



 MULTI-PROTOCOL COMMUNICATION INTERFACE	 OIL-FREE CENTRIFUGAL COMPRESSORS	 SPRAY FLOODED SHELL AND TUBE	 FAST RESTART
 AXIAL FANS	 CORROSION RESISTANT MATERIAL	 CLASS A	 SUPER LOW NOISE
 LOW GWP REFRIGERANT			

TTX is the most efficient range of air-cooled chillers specifically sized to meet the latest trends in the Data Center sector. The use of oil-free centrifugal compressors in combination with new flooded heat exchangers (minimum approach between water and refrigerant and reduced refrigerant charge compared to traditional flooded exchangers) allows the system **to fully exploit the highest efficiency levels**, especially at partial loads. Chillers in the TTX range can be selected with **HFO R1234ze refrigerant**, characterized by a very low **environmental impact**, minimizing the overall system TEWI.

- R1234ze refrigerant
- Water connections with Vic-Taulic quick couplings
- Dual day/night noise emission set-point
- EC Fans
- Electronic expansion valve
- Capacity modulation via inverter on both compressors or on a single compressor
- Monitoring and limitation of the maximum absorbed power
- Available with single or double pumping kit in timed rotation
- Glycol-Free kit available
- Dual power supply (optional)
- Active filter for harmonic distortion reduction (optional)



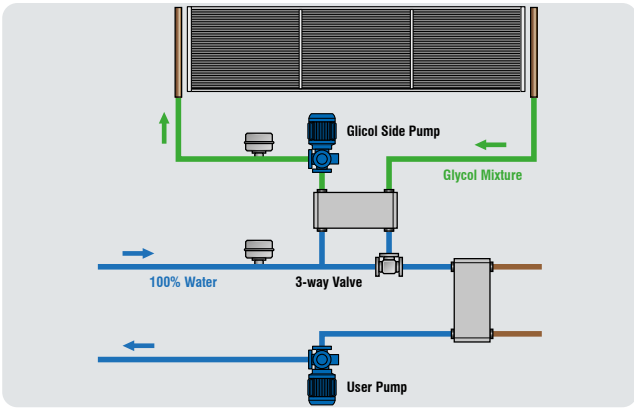

**Glycol-Free kit**

The Free-Cooling versions can be selected with the “Glycol- Free” kit (on board the unit) to confine the water-antifreeze mix inside the finned coils. This solution **maximises heat exchange efficiency at the evaporator** with the exclusive use of pure water; it also **dramatically reduces pumping costs**.

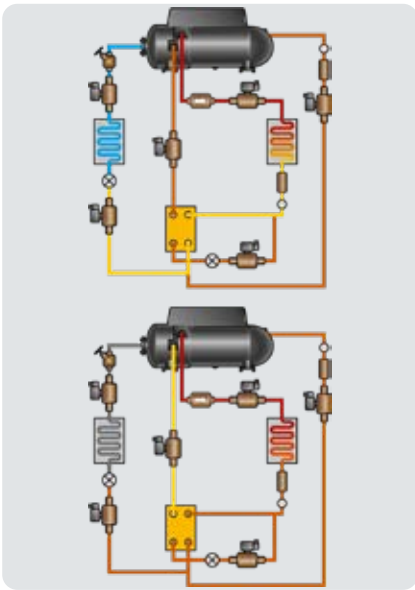

**Top-class thermodynamic performance!**

An effective combination of “oil-free” centrifugal compressor and flooded exchangers allows maximisation of thermal exchange efficiency; this is largely due to the absence of oil in the circuit and the reduced approach temperature between water and refrigerant (1K) as a result of no overheating in the evaporator. Cycle efficiency is enhanced by the centrifugal compressor, which provides **ultra-high efficiency at partial loads**, and by the economiser, which ensures **intermediate regenerative exchange in the circuit**.



**Maximum efficiency at partial loads**

Oil-free centrifugal compressors (up to 4 on a single refrigeration circuit), flooded heat exchangers, fan modulation, and variable flow management through circulation pumps: these are the main features that make the TTX range efficient at partial loads.



**Acoustic comfort**

**Two different soundproofing systems are available:** the most suitable one will depend on the importance of noise containment in the overall plant layout. Adopted technical solutions include fan speed control and compartmentalisation of compressors and pumping kits in a box internally lined with soundproofing material.



TTX		0500F	0600F	0902F	1202F	1403F	1603F	1904F	0500C	0600C	0902C	1202C	1403C	1603C	1904C	
<b>Cooling: User water temperature 30/20°C, outside air 40°C</b>																
<b>Cooling capacity</b>	kW	540	642	1038	1273	1531	1800	2066	547	649	1064	1302	1600	1856	2120	
<b>Total absorbed power</b>	kW	136	148.4	276	292	366	432	547	131	147	274	290	406	430	544	
<b>EER</b>		3.9	4.3	3.7	4.3	4.1	4.1	3.7	4.1	4.4	3.9	4.4	3.9	4.32	3.9	
<b>Dimensions [LxHxD]</b>	mm	4900 x2690 x2320	6430 x2690 x2320	7700 x2690 x2320	9160 x2690 x2320	12000 x2690 x2320	13420x2690x2320		4900 x2690 x2320	6340 x2690 x2320	7700 x2690 x2320	9160 x2690 x2320	12000 x2690 x2320	13420 x2690 x2320	13420 x2690 x2320	

Also available with 60 Hz power supply | Declared data with R1234ze refrigerant

# XTW

## WATER-CONDENSED CHILLERS WITH OIL-FREE CENTRIFUGAL COMPRESSORS

500-2400 kW



 MULTI-PROTOCOL COMMUNICATION INTERFACE	 OIL-FREE CENTRIFUGAL COMPRESSORS	 SPRAY FLOODED SHELL AND TUBE
 FAST RESTART	 CORROSION RESISTANT MATERIAL	 CLASS A
 SUPER LOW NOISE	 LOW GWP REFRIGERANT	

XTW offers the most innovative, efficient water condensed chiller solution. A meticulous choice of components and equipment layout has led to **a solution with numerous advantages as regards both energy performance and noise emissions**. The special component layout lets users maximise **the advantages provided by the oil-free centrifugal compressor** (maximum heat exchange efficiency, ultra-high efficiency at partial loads, reduced inrush current) and **the compact flooded exchangers** (minimal approach temperature between water and refrigerant, lower load compared to traditional flooded units).

- Available refrigerants: R1234ze and R515B
- Water connections with Vic-Taulic quick couplings
- Modulation and supervision managed by the software
- Low noise set-up with compressor insulation



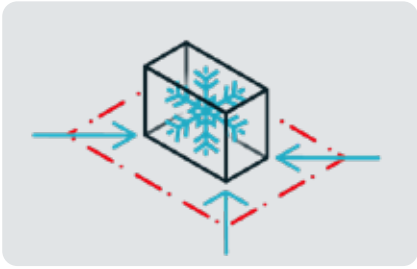

**Reduced footprint**

Careful assessment of component layout and sizing **allows the system footprint to be reduced**, freeing up more space within the facility and during handling operations.



**“Silent” layout**

The piping layout is designed and sized to ensure low noise emissions under all working conditions and **mitigate Coriolis force acceleration**. The use of high performance sound absorbing material in the **Low Noise configuration** results in a further **reduction of the compressor noise emissions**.

**Top-class thermodynamic performance!**

An effective combination of “oil-free” centrifugal compressor and flooded exchangers **allows maximisation of thermal exchange efficiency**; this is largely due to the absence of oil in the circuit and the reduced approach temperature between water and refrigerant (TK) as a result of no overheating in the evaporator. Cycle efficiency is enhanced by the centrifugal compressor, **which features ultra-high efficiency at partial loads**, and by the economiser, which **ensures intermediate regenerative exchange in the circuit**.

**Two-level evaporation**

The evaporator with spray technology and single pass on the water side **guarantees up to 5% more efficiency than traditional shell and tube versions**, thanks to the permanently countercurrent heat exchange on two separate evaporation levels - and with a **smaller refrigerant charge than a standard flooded shell and tube model**.

**24 hour operation**

The configuration with dual refrigerant circuit and dual centrifugal compressor with permanent magnets **guarantees high operational reliability**, making the XTW range particularly suitable **for installation in Data Centers or wherever high-value, continuous cycle industrial processes are carried out**.



XTW		0511	0611	1021	1221	1531	1831	2041	2441	
<b>Cooling: User water temperature 30/20°C, source water temperature 40/45°C</b>										
<b>Cooling capacity</b>	kW	500	600	1000	1200	1500	1800	2000	2400	
<b>Total power supply</b>	kW	94.9	110.8	193.8	225.7	284.7	332.4	387.6	451.4	
<b>EER</b>		5.27	5.42	5.16	5.32	5.27	5.42	5.16	5.32	
<b>Dimensions [LxHxD]</b>	mm	4670x2520x1950					5665x2520x1950			

Also available with 60 Hz power supply | Declared data with R1234ze refrigerant

# XVA

## WATER CONDENSED CHILLERS AND HEAT PUMPS WITH SCREW COMPRESSORS

445-1494 kW



 MULTI-PROTOCOL COMMUNICATION INTERFACE	 SCREW COMPRESSORS	 SHELL AND TUBE HEAT EXCHANGER	 FAST RESTART
 CORROSION RESISTANT MATERIAL	 CLASS A	 LOW GWP REFRIGERANT	

XVA is HiRef's range of water-cooled chillers with screw compressors and shell and tube heat exchangers. Use of the new R1234ze refrigerant, **with ultra-low GWP** (Global Warming Potential), and **achievement of high energy efficiency levels**, especially at partial loads, **ensures the system has a low TEWI** (Total Equivalent Warming Impact). The broad capacity range offered and the availability of different versions caters to a wide variety of needs. It's possible to choose operation in **chiller-only mode with evaporative tower or Dry Cooler** and **operation in heat pump mode** for high or low temperatures.

- Available refrigerants: R1234ze and R515B
- Available in versions: chilling only (with well water or evaporative tower), chilling only (with Dry Cooler), heating only heat pump
- Electronic expansion valve
- Monitoring and limitation of the maximum absorbed power
- Thermal insulating jackets on compressors
- Available with screw compressors driven by inverter

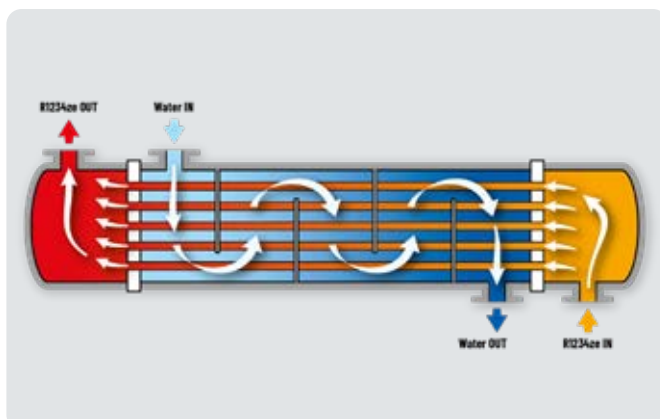

### New concept of heat exchange

Single pass shell and tube evaporators provide **excellent levels of thermodynamic efficiency** thanks to full heat exchange counter-flow.



**Power and flexibility**

Screw compressor allows **high cooling capacities** to be achieved with load modulation via the special slide valve. On request, a version with inverter either on one or on both compressors is available, **for finer adjustment of cooling capacity and obvious advantages in terms of energy efficiency.**

**Low Noise set-up**

The screw compressors, the only source of noise on the machine, can be placed in a dedicated enclosure lined with sound-absorbing material **that reduces the overall noise emission.**

**Suitable for coupling to Polymorph HiRef modules**

The XVA range offers **great versatility when combined with PLM hydronic modules**, allowing for different system configurations. Thanks to this flexibility, it can be used as: a reversible heat pump, a chiller with total recovery, a multi-purpose heat pump for 2-pipe systems, a multi-purpose heat pump for 4-pipe systems or an air conditioning system with Free-Cooling.



XVA		491D	541D	601D	681D	801D	921D	1141D	1281D	451D	551D	641D	701D	821D	911D	1061D	1221D	1291D	1431D	1501D	
<b>Cooling: User water values 12/7°C, 30/35°C source water side</b>																					
<b>Cooling capacity</b>	kW	488.5	563.7	648.5	729.4	871	953.7	1113.8	1289.1	444.6	542.3	618.2	709	811.6	903.4	1096.5	1215	1260	1419.9	1493.9	
<b>Total absorbed power</b>	kW	90.4	101.5	119.3	135.1	158.2	177.9	190.5	220.2	80.8	97.8	115.8	133.2	154.4	170.3	205.6	230.1	248.2	279.4	291.5	
<b>EER</b>		5.41	5.56	5.44	5.4	5.51	5.36	5.85	5.85	5.5	5.55	5.34	5.32	5.26	5.3	5.33	5.28	5.08	5.08	5.12	
<b>SEER</b>		7.63	7.52	7.52	7.56	7.54	7.52	7.88	7.94	7.63	7	6.79	6.93	6.94	6.94	7.03	6.99	7.23	7.52	7.55	
<b>SEPR</b>		8.15	8.01	8	8	8	8.16	8.03	8.01	8.15	8	8	8.06	8.04	8.04	8.12	8.05	8.13	8.55	8.55	
<b>Sound power [Standard]</b>	dB(A)	95	97	97	98	99	100	102	103	95	92	95	96	97	98	99	100	101	102	103	
<b>Dimensions [LxHxD]</b>	mm	4250x2050x1500				4800 x2250 x1500	5200 x2250 x1900	5200 x2250 x2050	4250x2050x1500				4800 x2250 x1500	5200x2250x1900				5400 x2250 x2050			



# **LIQUID CHILLERS AND REVERSIBLE HEAT PUMPS**

# CDA

## AIR-COOLED CHILLERS AND HEAT PUMPS WITH NATURAL REFRIGERANT R744 (CO<sub>2</sub>) AND MODULATING COMPRESSORS

75-706 kW



<p>REFRIGERANT R744 (CO<sub>2</sub>)</p>	<p>MULTI-PROTOCOL COMMUNICATION INTERFACE</p>	<p>PISTON COMPRESSORS</p>
<p>CLASS A</p>	<p>FAST RESTART</p>	<p>CORROSION RESISTANT MATERIAL</p>

CDA is the new range of water chillers designed by HiRef for applications that require **energy efficiency and environment-friendliness**. Low environmental impact is guaranteed by the use of CO<sub>2</sub> as a refrigerant fluid (R744) which is characterised by a unit GWP (Global Warming Potential) value equal to 1. High efficiency/footprint ratios are achieved thanks to the use of inverter-driven compressors and finned pack exchangers with a large exchange surface installed in a “V” configuration.

- Aisi 316L stainless steel refrigeration circuit
- Low pressure side PS: 85 bar
- EC Fans
- Available in the following versions: chiller, reversible heat pump, and Free-Cooling chiller

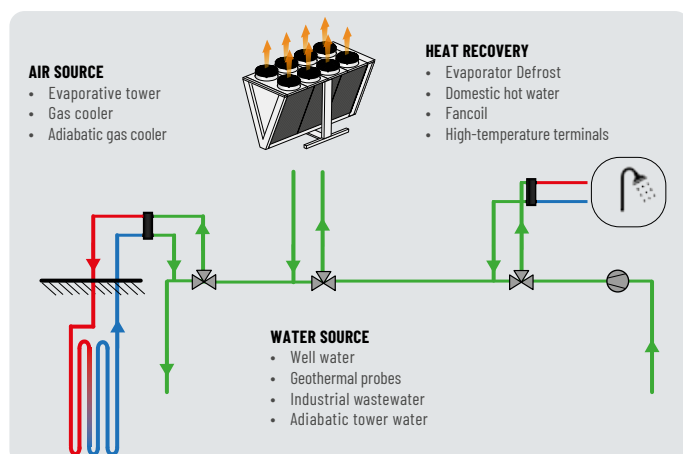

### Very high temperature and multi-source heat recovery

CO<sub>2</sub> in the transcritical system allows several exchangers to be placed in series on the dissipation side. A typical configuration includes:

- **a partial or total heat recovery exchanger** that recovers the dissipated heat and produces instantaneous hot water at very high temperatures (over 90°C), without altering the operation of the unit. A typical application is the production of instantaneous hot water;
- **an exchanger with dissipation in water using well water or geothermal probes**, to further cool the CO<sub>2</sub> and guarantee greater efficiency and cooling performance during the most critical periods of operation.

### Natural refrigerant

The refrigerant R744 is a natural gas, largely available in nature and without limitations of use. In addition, it is inert, non-toxic and, more importantly, non-flammable, all of which contributes **to reducing costs and the difficulties associated with installing the systems safely**. This refrigerant can be widely used in the field of commercial refrigeration; among other things, it offers good thermodynamic performance due to its inherently favourable chemical and physical properties.

### Modular and efficient

The configuration with very deep modular 'V' coils provides an extensive heat exchange surface area and therefore **excellent thermal efficiency levels in relation to the unit footprint**. Another special feature is the material of the coil tubes (alloy of copper and steel) which ensures mechanical **strength to high pressures (up to 130 bar) and heat transfer coefficients greater than those of stainless steel-only tubes**. By connecting in parallel each CDA unit via special kits (on request) a modular configuration can be obtained capable of meeting **high cooling capacity** requirements and guaranteeing **high redundancy**, with full system management via the on-board electronics.

### Maximum efficiency at partial loads

By choosing a single refrigeration circuit configuration with an inverter-driven compressor, by using EC electronically commutated fans (standard), and by managing variable flow through the circulation pumps (included), **maximum partial-load efficiency of the CDA range is guaranteed**.



CDA		060	091	111	121	141	201	241	303	353	384	404
<b>Cooling: User water values 12/7°C, 35°C outside air, 40% U.R.</b>												
Cooling capacity	kW	579	75.2	92.6	115.5	138.5	197.4	234.8	304.7	348.6	386.2	457.4
Total absorbed power	kW	23.1	29.3	37	48.3	52.9	83.9	98.6	126	147.8	160.6	183.1
EER		2.5	2.57	2.5	2.39	2.62	2.35	2.38	2.42	2.36	2.4	2.5
Sound power [Standard]	dB(A)	80	82	84	85	86	88	89	90	90	92	92
Sound power [Low noise]	dB(A)	77	79	81	82	83	85	86	87	87	89	89
Dimensions [LxHxD]	mm	1470x2715x2255				2940x2715x2255			4410x2715x2255		5880x2715x2255	
<b>Heating: User water values 20/60°C, outside air 7°C, 87% U.R.</b>												
Thermal power	kW	93.1	120.4	147.5	182.9	217	321.9	366	482.8	549	615.7	706.2
Total absorbed power	kW	22.8	32.4	39.1	48.3	52.9	86.9	99	130.4	148.5	167.9	183.7
COP		4.09	3.71	3.77	3.79	4.10	3.70	3.70	3.70	3.70	3.67	3.85
Sound power [Standard]	dB(A)	80	82	84	85	86	88	89	90	90	92	92
Sound power [Low noise]	dB(A)	77	79	81	82	83	85	86	87	87	89	89
Dimensions [LxHxD]	mm	1470x2715x2255				2940x2715x2255			4410x2715x2255		5880x2715x2255	
CDA-F		060	091	111	121	141	201	241	303	353	384	404
<b>Cooling: User water values 12/7°C, 35°C outside air, 40% U.R.</b>												
Cooling capacity	kW	57.9	75.2	92.6	115.5	138.5	197.4	234.8	304.7	348.6	386.2	457.4
Total absorbed power	kW	23.1	29.3	37	48.3	52.9	83.9	98.6	126	147.8	160.6	183.1
EER		2.5	2.57	2.5	2.39	2.62	2.35	2.38	2.42	2.36	2.4	2.5
Sound power [Standard]	dB(A)	80	82	84	85	86	88	89	90	90	92	92
Sound power [Low noise]	dB(A)	77	79	81	82	83	85	86	87	87	89	89
Dimensions [LxHxD]	mm	1470x2715x2255				2940x2715x2255			4410x2715x2255		5880x2715x2255	

Also available with 60 Hz power supply

# TSS

## CLASS A CHILLERS AND HEAT PUMPS AIR CONDENSED WITH SCROLL COMPRESSORS

120–265 kW



 MULTI-PROTOCOL COMMUNICATION INTERFACE	 SCROLL COMPRESSORS	 AXIAL FANS
 CORROSION RESISTANT MATERIAL	 A2L READY	 LOW GWP REFRIGERANT
 CLASS A	 SHELL AND TUBE HEAT EXCHANGER	

The new TSS range chillers and heat pumps are air/water units in energy class A for both cooling and heating, available for use with R410A refrigerant or, in the "A2L" version, with low environmental impact R454B refrigerant. The TSS range is designed **to manage the conditioning of industrial plants and thermal loads in technological applications where 24/7 system reliability is required**. The TSS range uses latest-generation Scroll compressors, shell and tube water heat exchangers optimised for use with **high pressure refrigerants** (R410A/R454B) and axial fans suitable for outdoor installation.

- 3 different soundproofing setups available: Standard, Low Noise and Super Low Noise
- High power density units in both chiller and heat pump modes
- Electronic expansion valve
- Optional EC fans
- Easy accessibility thanks to the optimisation of the internal space

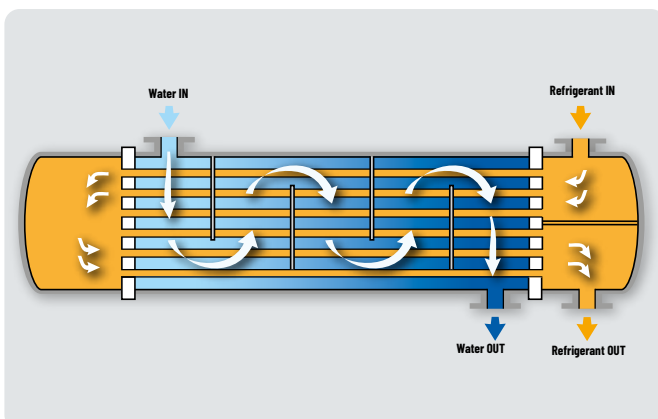

### Reliability: shell and tube

The use of shell and tube heat exchangers with exchange water flow on the shell side implies **a lower risk of blocking the flow** due to exchanger clogging compared to units with plate heat exchangers. This is thanks to **the larger throughsections**, the exchanged power being the same. Additionally, the dual-pass heat exchanger **ensures high heat exchange efficiency** both in "chiller" and in "heat pump" modes, with lower consumption figures for the user.



**Acoustic comfort**

It is possible to choose between **three different soundproofing configurations**. The solutions include fan speed management, the use of anti-vibration components on the refrigeration circuit, and the placement of the compressors in a box internally lined with sound-absorbing material.



**Maximised energy efficiency**

The units of the TSS range belong to the **energy efficiency class A**, both in the chilling only version and in the heat pump version. This is thanks to a careful selection of internal components, which also includes the adoption of **innovative high efficiency Scroll compressors with direct start, permanent magnet motor technology**. The high modulation range guaranteed by the multi-Scroll technology allows cooling/heating requirements **to be met at any time, minimising energy waste and increasing seasonal efficiency**.



TSS		114CS	124CS	144CS	164CS	194CS	214CS	244CS
<b>Cooling: User water values 12/7°C, 35°C outside air, 40% U.R.</b>								
Cooling capacity	kW	120.3	130.2	152.4	164.9	190.2	225.7	251.4
Total absorbed power	kW	34	36.2	43.6	47.5	56	71.1	80
EER		3.54	3.59	3.5	3.47	3.4	3.17	3.14
SEER		4.95	4.83	4.86	4.98	4.97	4.9	4.78
SEPR		5.66	5.7	5.7	5.82	5.86	5.7	5.74
<b>Heating: User water values 40/45°C, 7°C outside air, 89% U.R.</b>								
Thermal power	kW	123.9	130.8	149.9	163.1	186.9	227.5	265.2
Total absorbed power	kW	34.1	36.2	42.5	46.8	53.4	65.1	75.4
COP		3.63	3.61	3.53	3.49	3.5	3.49	3.52
SCOP		3.95	3.85	3.86	3.93	4.05	4.18	4.24
Sound power [Standard]	dB(A)	83	84	86	86	87	88	89
Sound power [Low noise]	dB(A)	80	81	83	83	84	85	86
Sound power [Super Low noise]	dB(A)	78	80	82	82	84	84	85
Dimensions [LxHxD]	mm	3540x1735x1183		3540x1846x1653		3540x2330x1653		4206x2330x1653





Also available with 60 Hz power supply | Data declared with use of R410A refrigerant

# TAS

## AIR CONDENSED CHILLERS AND HEAT PUMPS WITH SCROLL COMPRESSORS

60-261 kW



 MULTI-PROTOCOL COMMUNICATION INTERFACE	 SCROLL COMPRESSORS	 AXIAL FANS
 CORROSION RESISTANT MATERIAL	 A2L READY	 LOW GWP REFRIGERANT
 PLATE HEAT EXCHANGER		 CLASS A

TAS is the range of air-condensed liquid chillers and heat pumps with Scroll compressors. Three different versions (chiller, Free-Cooling chiller and reversible heat pump) and the several available power output rates make these units **highly versatile and suited to a wide range of system set-ups**. The sizing and selection of individual components have focused on containing energy consumption, aiming to optimise energy savings not just for individual chillers but for the entire system. The unit is suitable for being installed in environments where **noise abatement is fundamentally important**; three different soundproofing set-ups are available. The configurations available for the refrigeration circuit are:

**EFFICIENCY PACK 1:** Dual compressor dual circuit unit for higher redundancy systems.

**EFFICIENCY PACK 2:** Dual compressor (tandem) on single circuit for greater efficiency at partial loads.

**EFFICIENCY PACK 4:** Four compressors (dual tandem) on dual circuit, for a redundant system that is efficient with low loads.

- 3 different soundproofing setups available: Standard, Low Noise and Super Low Noise
- Electronic expansion valve
- Optional EC fans
- Easy accessibility thanks to the optimisation of the internal space
- Available with variable flow pumping kit



**Plate heat exchangers**

The TAS range uses brazewelded plate exchangers with asymmetrical channels, suitable for the use of high and medium pressure refrigerant gases. The configuration with asymmetrical channels allows **high exchange efficiencies** to be reached while maintaining pressure drops low on the water side - **reducing pumping costs** at both full and partial load.



**Acoustic comfort**

It is possible to choose between **three different soundproofing configurations**. The solutions include fan speed management, the use of anti-vibration components on the refrigeration circuit, and the placement of the compressors in a box internally lined with sound-absorbing material.



**All accessories on-board the machine**

The special component layout, together with compact plate heat exchangers and Scroll compressors, allows users on the one hand to make **the most of large sized condensing sections** and on the other hand, to have sufficient Free-Cooling internal space available for fitting **a wide range of accessories and hydraulic options**. The hydraulic circuit may include a dual shut-off pump, flow switch, tank, expansion tank and safety valve.



**Maximum efficiency at partial loads**

The adoption of the multi-Scroll solution, the use of electronically controlled expansion valves, selection of plate heat exchangers, fan modulation and variable flow rate controlled with circulation pumps are all key features that make the **TAS range particularly efficient at partial loads**.

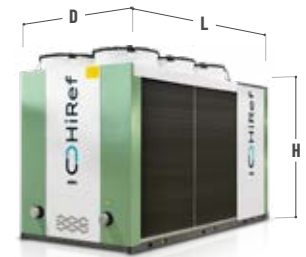

TAS		061FS	071FS	081FS	101FS	114FS	124FS	144FS	164FS	194FS	214FS	244FS
<b>User water temperature 12/7°C 20% ethylene glycol, outside air 35°C, 40% R.H.</b>												
Cooling capacity	kW	60.4	74.3	87.1	100.8	116.4	124.5	146.8	159.3	184.6	218.6	246.1
Total absorbed power	kW	17	21.5	25.9	30	34.1	36.6	44.3	48.3	56.7	72.1	81.3
EER		3.55	3.45	3.36	3.36	3.42	3.4	3.31	3.3	3.26	3.03	3.03
Full free-cooling temperature	°C	-1.5	-3.2	-5.3	-4.9	-6.5	-4.8	-6.5	-8.1	-5.8	-8.2	-6.5
<b>Cooling: User water values 12/7°C, 35°C outside air, 40% U.R.</b>												
Cooling capacity	kW	61.5	75.5	88.5	102.8	118.2	127	149.6	162.5	187.7	222.6	260.4
Total absorbed power	kW	16.9	21.4	25.6	29.6	33.8	35.9	43.3	47.2	55.9	71	80
EER		3.63	3.53	3.45	3.47	3.5	3.54	3.46	3.44	3.36	3.14	3.13
SEER		4.68	4.82	4.94	4.71	4.87	4.76	4.79	4.91	4.9	4.81	4.76
SEPR		5.33	5.49	5.73	5.45	5.59	5.61	5.65	5.76	5.77	5.61	5.69
<b>Heating: User water values 40/45°C, 7°C outside air, 89% U.R.</b>												
Thermal power	kW	60.3	74.2	85.5	100.7	121.3	127.6	147	159.6	183.2	223.4	260.5
Total absorbed power	kW	18.8	22.7	26.6	31.3	36.4	39.6	45.2	49.8	57.2	69.8	81.5
COP		3.21	3.27	3.21	3.22	3.33	3.23	3.25	3.21	3.2	3.2	3.2
SCOP		3.45	3.83	3.81	3.74	3.7	3.59	3.61	3.67	3.77	3.9	3.93
Sound power [Standard]	dB(A)	81	83	83	86	83	84	86	86	87	88	89
Sound power [Low noise]	dB(A)	78	80	80	83	80	81	83	83	84	85	86
Sound power [Super Low noise]	dB(A)	76	78	78	81	78	80	82	82	84	84	85
Dimensions [LxHxD]	mm	2792x1735x1183			3340 x1735 x1183	3540 x1735 x1183	3540x1846x1653			3540x2330x1653		4206 x2330 x1653

Also available with 60 Hz power supply | Features referred to the standars set-up. If not available, these features are referred to the Low Noise or Super Low Noise set-ups | Data declared with use of R410A refrigerant

# MHA

## AIR CONDENSED CHILLERS AND HEAT PUMPS WITH SCROLL BLDC INVERTER COMPRESSORS

30-288 kW



MULTI-PROTOCOL COMMUNICATION INTERFACE	SCROLL COMPRESSORS	INVERTER DRIVEN COMPRESSORS
AXIAL FANS	CORROSION RESISTANT MATERIAL	A2L READY
LOW GWP REFRIGERANT	PLATE HEAT EXCHANGER	

MHA is the HiRef range of air condensed liquid chillers and heat pumps that uses a combination of Scroll ON/OFF compressors and modulating BLDC (Brushless DC-inverter) compressors. **Thanks to timely control of the supplied refrigerating power, based on the achievement of maximum system delivery or energy efficiency, the running costs of the system are minimised.** The excellent configurability of the range in terms of refrigerating circuit, noise levels and available power ratings, together with the numerous accessories and options, make MHA chillers **highly versatile and suitable for a wide range of system applications.**

- Available refrigerants: R410A and R454B
- Electronic expansion valve
- Available in version: Liquid chiller, Free-Cooling chiller and reversible heat pump
- Variable flow management up to 25% of the nominal flow rate
- Quick water connections
- Optional electronic flow switch

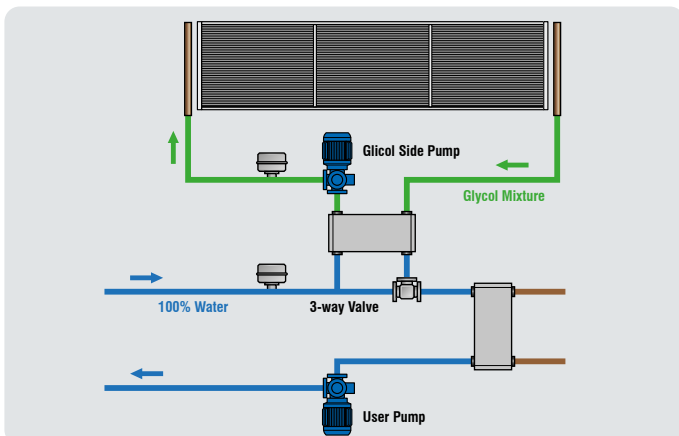

### Glycol-Free kit

The Free-Cooling versions can be selected with the **"Glycol-Free" kit** (on board the unit) to confine the water-antifreeze mix inside the finned coils. This solution **maximises heat exchange efficiency** at the evaporator with the exclusive use of pure water; it also **dramatically reduces pumping costs.**



**Attention to detail and to low noise requirements**

Depending on how important noise containment is in the overall plant layout, a standard version or a **Low Noise version** can be chosen. Adopted technical solutions include fan speed control, the use of anti-vibration devices on the refrigerating circuit, compartmentalisation of compressors and pumping kits in a box internally lined with soundproofing material (**the new HI-BOX by HiRef**).



**Advantages of modulation**

DC-inverter compressors are frequency modulated: from an electrical viewpoint, **this significantly reduces inrush current**.

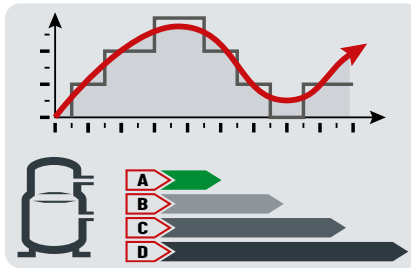

**Dual management of the delivered power**

The control software integrated on the MHA range allows management of the cooling capacity, delivered by the Scroll ON/OFF compressors combined with BLDC modulating compressors, according to a dual logic:

- **Maximum power:** the compressors are driven by the inverters at maximum frequency to quickly reach set-point conditions.
- **Maximum efficiency:** the software calculates the point of highest machine efficiency to minimise running costs. This function is particularly effective in the Free-Cooling versions.

**Maximum efficiency at partial loads**

The high precision of the hot-wire flow switch (up to 1/10 of the nominal flow rate), combined with pump modulation via the control software, **allows an ideal combination of machine delivery and water flow rate in the primary circuit. This optimises the water flow** required at each operating point and **reduces the power absorbed by the hydraulic module**, preventing the risk of ice formation in the evaporator.



**Efficiency and reliability in line with system requirements**

Users can select, according to unit size and specific plant engineering requirements, refrigerating circuits with different set-ups:

- EFFICIENCY PACK 1:** Dual compressor on dual circuit for high system redundancy.
- EFFICIENCY PACK 2:** Dual compressor (tandem) on single circuit for greater efficiency at partial loads.
- EFFICIENCY PACK 3:** Three compressors (trio) on single circuit for higher efficiency at partial loads.
- EFFICIENCY PACK 4:** Four compressors (dual tandem) on dual circuit, for a redundant system that is also efficient with low loads.



MHA	030	035	061	062	081	082	101	102	104	121	122	124	141	142	144	171	172	174	204	244	294	
<b>Utility water temperature 12/7°C, ethylene glycol 20%</b>																						
<b>Full free-cooling temperature</b>	°C	1.6	-1.1	2.2	-	0.6	-	-0.3	-	-0.8	0.6	-	0.5	1.2	-	0.6	0.4	-	-0.4	-0.1	0.1	-1.2
<b>Cooling: User water values 12/7°C, 35°C outside air, 40% U.R.</b>																						
<b>Cooling capacity</b>	kW	30.2	40.3	57.8	57.7	75.7	76.4	98.2	98.9	102.4	124.9	127.3	126.6	146.1	147.4	155.7	156.3	156.7	170.4	200.9	252.8	278.6
<b>Total absorbed power</b>	kW	11.3	14.9	18.9	18.8	24.4	24.4	34.2	34.1	37.5	44	43.2	43.4	48.6	48.4	52.3	52.3	52.2	58.7	72.7	86.9	99.4
<b>EER</b>		2.68	2.7	3.07	3.07	3.1	3.13	2.87	2.9	2.73	2.84	2.95	2.91	3.01	3.04	2.98	2.99	3	2.9	2.76	2.91	2.8
<b>SEER</b>		4.5	4.57	4.39	5.17	4.43	5.23	4.18	4.88	4.48	4.28	5.19	4.71	4.27	5.03	4.5	4.19	4.95	4.44	4.55	4.68	4.62
<b>SEPR</b>		5.08	5	6.14	6.08	6.31	6.39	5.62	5.58	5.31	5.7	5.79	5.61	5.9	5.97	5.27	5.75	5.86	5.3	5.35	5.69	5.69
<b>Weight</b>	kg	418	424	600	600	789	789	789	789	789	1085	1085	1085	1390	1390	1390	1430	1430	1470	1620	1943	1985
<b>Heating: User water values 40/45°C, 7°C outside air, 89% U.R.</b>																						
<b>Thermal power</b>	kW	31.7	42.2	-	57.5	-	75.9	-	100.8	106.8	-	133.6	133.5	-	149.8	159	-	160.5	178.1	210.1	257	287.6
<b>Total absorbed power</b>	kW	11.7	15.7	-	19.9	-	26	-	35	38.1	-	45.1	45.7	-	51.8	55.5	-	55.6	61.4	74	89.4	100.4
<b>COP</b>		2.7	2.69	-	2.88	-	2.92	-	2.88	2.8	-	2.96	2.92	-	2.89	2.86	-	2.89	2.9	2.84	2.88	2.86
<b>SCOP</b>		3.28	3.32	-	3.2	-	3.21	-	3.34	3.32	-	3.36	3.22	-	3.22	3.21	-	3.2	3.2	3.36	3.27	3.31
<b>Weight</b>	kg	423	430	-	600	-	789	-	789	789	-	1085	1085	-	1390	1390	-	1430	1495	1655	1980	2025
<b>Sound power [Standard]</b>	dB(A)	87	92	87	87	88	88	90	90	90	94	94	88	94	94	90	94	94	90	94	94	94
<b>Sound power [Low noise]</b>	dB(A)	85	90	83	83	86	84	86	86	86	90	90	84	90	90	86	90	90	86	90	90	90
<b>Dimensions [LxHxD]</b>	mm		1661 x1468 x914	2440 x1735 x1185		2972x1735x1185				3540x1735x1185					3540x1847x1653				3538 x2247 x1653	4206 x2247 x1653		

Also available with 60 Hz power supply

# TPS

## AIR CONDENSED CHILLERS AND HEAT PUMPS WITH SCROLL COMPRESSORS

43-445 kW



 MULTI-PROTOCOL COMMUNICATION INTERFACE	 SCROLL COMPRESSORS	 AXIAL FANS	 CORROSION RESISTANT MATERIAL
 A2L READY	 LOW GWP REFRIGERANT	 PLATE HEAT EXCHANGER	

TPS is the range of air-condensed liquid chillers and heat pumps with Scroll compressors. Three different versions (chiller, Free-Cooling chiller and reversible heat pump) and the several available power output rates make these units **highly versatile and suited to a wide range of system set-ups**. The sizing and selection of individual components have focused **on containing energy consumption, aiming to optimise energy savings not just for individual chillers but for the entire system**. The unit is available with **three soundproofing set-ups**. The configurations available for the refrigeration circuit are:

**EFFICIENCY PACK 1:** Dual compressor dual circuit unit for higher redundancy systems.

**EFFICIENCY PACK 2:** Dual compressor (tandem) on single circuit for greater efficiency at partial loads.

**EFFICIENCY PACK 4:** Four compressors (dual tandem) on dual circuit, for a redundant system that is efficient with low loads.

- 3 different soundproofing setups available: Standard, Low Noise and Super Low Noise
- Optional EC fans
- Electronic expansion valve
- Easy accessibility thanks to the optimisation of the internal space
- Available with variable flow pumping kit

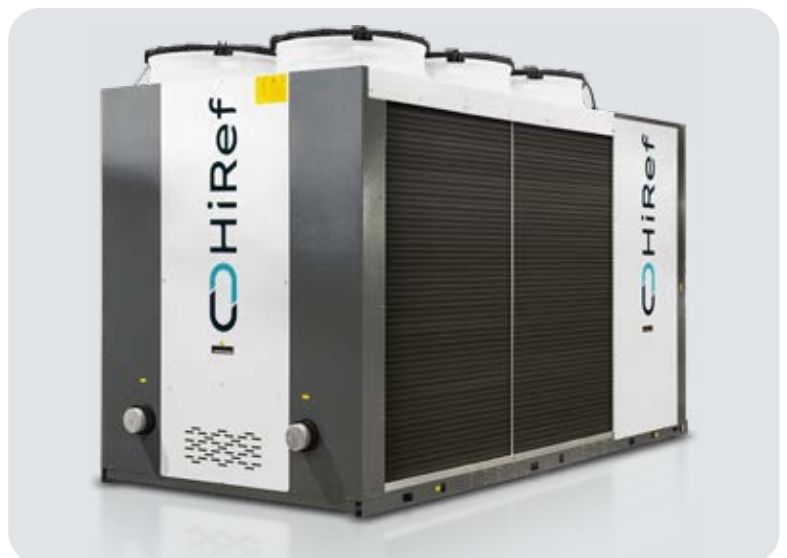



**Acoustic comfort**

**Three different soundproofing set-ups are available:** the most suitable one will depend on the importance of noise containment in the overall plant layout. Adopted technical solutions include fan speed control, the use of anti-vibration devices on the refrigerating circuit, compartmentalisation of compressors and pumping kits in a box internally lined with soundproofing material.



**All accessories on-board the machine**

The special component layout, together with compact plate heat exchangers and Scroll compressors, allows users on the one hand to make **the most of large sized condensing sections** and on the other hand, to have sufficient Free-Cooling internal space available for fitting **a wide range of accessories and hydraulic options**. The hydraulic circuit may include a dual shut-off pump, flow switch, tank, expansion tank and safety valve.



**Maximum efficiency at partial loads**

The adoption of the multi-Scroll solution, the use of electronically controlled expansion valves, selection of plate heat exchangers, fan modulation and variable flow rate controlled with circulation pumps are all key features that make **the TPS range particularly efficient at partial loads**.



TPS		042	052	062	072	082	092	102	122	124	142	144	162	164	
<b>Cooling: User water values 12/7°C, 35°C outside air, 40% U.R.</b>															
Cooling capacity	kW	43.2	54.4	63.1	70.9	78.5	94.4	105.6	122.4	125.3	133.7	141.4	160.5	156.2	
Total absorbed power	kW	13.1	18.3	20.7	24.3	28.1	32.6	38.5	40.8	42.1	43.9	48.3	59.2	55.9	
EER		3.31	2.98	3.05	2.91	2.79	2.9	2.74	3	2.98	3.04	2.93	2.71	2.79	
SEER		4.98	4.9	4.63	4.58	4.52	4.35	4.39	4.54	4.53	4.71	4.61	4.34	4.54	
SEPR		5.69	5.72	5.3	5.38	5.38	5.31	5.22	5.35	5.32	5.41	5.38	5.13	5.38	
Weight	kg	525	525	540	570	650	730	730	1010	1050	1055	1070	1085	1220	
<b>Heating: User water values 40/45°C, 7°C outside air, 89% U.R.</b>															
Thermal power	kW	50.7	57.1	64.2	72.6	80.8	96	108.7	124	126.9	142.4	151.8	175.8	169.6	
Total absorbed power	kW	16.8	19.1	22.3	25.1	28.3	33.8	38.6	42.8	44	46.9	51.2	58.7	56.8	
COP		3.02	2.99	2.87	2.89	2.86	2.85	2.82	2.9	2.89	3.03	2.97	3	2.99	
SCOP		3.99	3.99	3.66	3.73	3.71	3.58	3.66	3.68	3.54	3.69	3.58	3.68	3.68	
Weight	kg	545	545	585	585	675	755	760	1050	1090	1100	1120	1155	1270	
Sound power [Standard]	dB(A)	72	73	79	80	82	85	86	86	82	86	83	87	85	
Dimensions [LxHxD]	mm	2090x1740x1180					2640x1740x1180			x1740 x1180	x1740 x1180	x1740 x1180	x1740 x1180	x1740 x1180	x1740 x1180
TPS		174	192	194	212	214	242	244	272	274	294	324	364	394	
<b>Cooling: User water values 12/7°C, 35°C outside air, 40% U.R.</b>															
Cooling capacity	kW	166.2	189.1	188.4	207.6	211.2	230.1	232	267.2	266	293.2	317.5	352	397.6	
Total absorbed power	kW	54.2	65.4	65.4	73.9	77.5	82.8	85.2	90.3	89.5	104.9	120.5	136.9	153.8	
EER		3.06	2.89	2.88	2.81	2.72	2.78	2.72	2.96	2.97	2.79	2.63	2.57	2.59	
SEER		4.62	4.31	4.28	4.37	4.32	4.27	4.31	4.61	4.6	4.25	4.23	4.15	4.28	
SEPR		5.43	5.18	5.32	5.13	5.19	5.32	5.4	5.42	5.51	5.29	5.1	5.21	5.22	
Weight	kg	1440	1430	1460	1430	1470	1620	1620	1943	1943	1975	2010	2060	3090	
<b>Heating: User water values 40/45°C, 7°C outside air, 89% U.R.</b>															
Thermal power	kW	172.8	199.6	199.3	220.4	226.2	243.7	247.4	275.7	278	311	342.1	395.8	444.7	
Total absorbed power	kW	59	68.9	69.5	75.4	79.1	82.8	85.5	91.4	93	105.7	118.5	132.7	147.5	
COP		2.93	2.9	2.87	2.92	2.86	2.94	2.89	3.02	2.99	2.94	2.89	2.98	3.01	
SCOP		3.32	3.49	3.41	3.55	3.49	3.66	3.62	3.66	3.54	3.5	3.54	3.62	3.56	
Weight	kg	1495	1485	1515	1485	1530	1690	1690	2015	2015	2050	2101	2191	3190	
Sound power [Standard]	dB(A)	86	92	87	92	89	94	89	89	94	93	95	94	97	
Dimensions [LxHxD]	mm	3540x1847x1653					3540x2247x1653			4200x2330x1653			4296 x2330 x1653	5350 x2330 x1653	

Also available with 60 Hz power supply | Calculated with 20% glycol. The Free-Cooling versions always feature a refrigeration configuration consisting of one compressor per circuit or dual tandem on two circuits | Features referred to the standard set-up. If not available, they refer to the Low Noise or Quiet set-up | Data declared with use of R410A refrigerant

# TSL

## CLASS A CHILLERS AND HEAT PUMPS AIR CONDENSED WITH SCROLL COMPRESSORS

277-1004 kW



MULTI-PROTOCOL COMMUNICATION INTERFACE	CORROSION RESISTANT MATERIAL	CLASS A
LOW GWP REFRIGERANT	SCROLL COMPRESSORS	SHELL AND TUBE HEAT EXCHANGER

The TSL range chillers and heat pumps are air/water units in energy class A for both cooling and heating, available for use with R410A refrigerant or, in the "A2L" version, with low environmental impact R454B refrigerant. The TSL range is designed to manage the **conditioning of industrial plants and thermal loads in technological applications, where 24/7 reliability in all working conditions, one of the assets of these units, is a critically important requirement.** The TSL range uses latest generation Scroll compressors, shell and tube water heat exchangers optimised for use with high pressure refrigerants (R410A/R454B) and axial fans suitable for outdoor installation.

- 3 different soundproofing setups available: Standard, Low Noise and Super Low Noise
- High power density units in both chiller and heat pump modes
- Optional EC fans
- Electronic expansion valve
- Easy accessibility thanks to the optimisation of the internal space

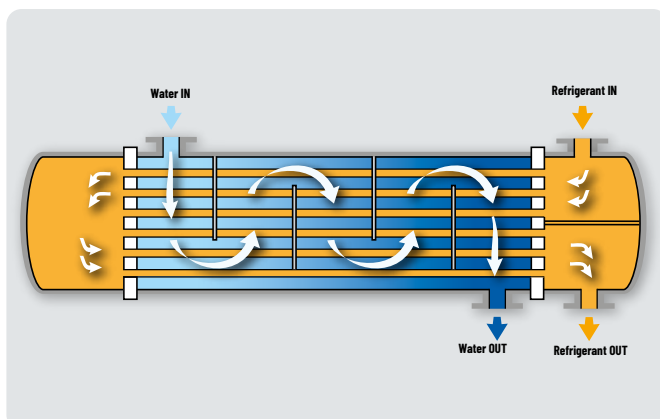

### Reliability: shell and tube

The use of shell and tube heat exchangers with exchange water flow on the shell side implies a **lower risk of blocking the flow** due to exchanger clogging compared to units with plate heat exchangers. This is thanks to the **larger throughsections**, the exchanged power being the same. Additionally, the dual-pass heat exchanger **ensures high heat exchange efficiency** both in "chiller" and in "heat pump" modes, **with lower consumption figures for the user.**



**Easy maintenance**

To carry out maintenance of the condensing coil manifolds and refrigeration circuit components, which are located behind the electrical panel, the TSL range is supplied as standard with the Hi-Rail sliding guide. This allows **the control panel to be easily removed**, resulting in **extra space for unscheduled maintenance**, without impacting the footprint required for normal operation of the unit.

**Maximised energy efficiency**

The units of the TSL range belong to the energy **efficiency class A**, both in the chilling only version and in the heat pump version. This is thanks to a careful selection of internal components, which also includes the adoption **of innovative high efficiency Scroll compressors with direct start, permanent magnet motor technology**. The high modulation range guaranteed by the multi-Scroll technology allows cooling/heating requirements to be met at any time, **minimising energy waste and increasing seasonal efficiency**.



TSL	294FS	324FS	374FS	404FS	454FS	496FS	556FS	596FS	636FS	676FS	748FS	808FS	868FS	900FS	
<b>User water temperature 12/7°C 20% ethylene glycol, outside air 35°C, 40% R.H.</b>															
Cooling capacity	kW	276.9	319.4	354.2	383.2	422.9	478.9	545.6	585.7	608.1	648.6	725.3	791.8	848.6	910.9
Total absorbed power	kW	89.7	105.8	118.3	129.2	150.4	155.8	179.4	195.8	205.4	221.1	235.4	258.1	270.8	299.7
EER		3.09	3.02	2.99	2.97	2.81	3.07	3.04	2.99	2.96	2.93	3.08	3.07	3.13	3.04

<b>Utility water temperature 12/7°C, ethylene glycol 20%</b>																	
Full free-cooling temperature	°C	-8.7	-10.4	-6.4	-7.3	-8.6	-6.2	-8.1	-9.2	-6.7	-7.7	-6.8	-8.1	-7.1	-8		
Sound power [Standard]	dB(A)	89	90	90	90	92	91	92	91	93	93	93	93	94	94		
Sound power [Low noise]	dB(A)	86	87	87	87	89	87	89	88	90	90	90	90	91	91		
Sound power [Super Low noise]	dB(A)	83	85	85	85	86	85	87	86	87	88	88	87	88	89		
Dimensions [LxHxD]	mm	3865x2652x2256			4865x2652x2256			5860x2652x2256			6860x2652x2256			7865x2652x2256		8865x2652x2256	

TSL	294CS	324CS	374CS	404CS	454CS	496CS	556CS	596CS	636CS	676CS	748CS	808CS	868CS	900CS			
<b>Cooling: User water values 12/7°C, 35°C outside air, 40% U.R.</b>																	
Cooling capacity	kW	281.5	326.1	364.2	396.6	436.1	485.9	549.9	598.9	617.1	658.3	734.3	794.1	861.2	923.2		
Total absorbed power	kW	88.7	104.2	117	127.6	148.6	153.7	176.9	193	202.7	218	232.5	254.7	267.6	295.7		
EER		3.18	3.13	3.11	3.11	2.93	3.16	3.11	3.1	3.04	3.02	3.16	3.12	3.22	3.12		
SEER		4.9	4.99	4.82	4.87	5.03	5.02	5.09	5.18	5.06	5.14	4.77	4.81	4.88	4.84		
SEPR		5.46	5.62	5.38	5.49	5.74	5.56	5.64	5.79	5.67	5.75	5.53	5.58	5.65	5.71		
Sound power [Standard]	dB(A)	89	90	90	90	92	91	92	91	93	93	93	93	94	94		
Sound power [Low noise]	dB(A)	86	87	87	87	89	87	89	88	90	90	90	90	91	91		
Sound power [Super Low noise]	dB(A)	83	85	85	85	86	85	87	86	87	88	88	87	88	89		
Dimensions [LxHxD]	mm	3520x2652x2256			4520x2652x2256			5520x2652x2256			6520x2652x2256			7520x2652x2256		8520x2652x2256	

TSL	294HS	324HS	374HS	404HS	454HS	496HS	556HS	596HS	636HS	676HS	748HS	808HS	868HS	900HS		
<b>Heating: User water values 40/45°C, 7°C outside air, 89% U.R.</b>																
Thermal power	kW	291.9	337	390.9	412.9	448.8	504.5	566	603.9	656.7	683.9	776.9	841	883.1	1003.8	
Total absorbed power	kW	89.1	102.3	119.2	126	143.4	153.6	173.3	184.1	200.6	213.5	231.3	250.5	267.9	295.1	
SEER		-	-	-	-	-	-	-	5.19	5.1	5.2	4.63	4.69	4.73	4.63	
COP		3.27	3.29	3.28	3.28	3.13	3.28	3.27	3.28	3.27	3.2	3.36	3.36	3.3	3.4	
SCOP		4.01	4.17	4.1	4.1	4.24	3.82	3.99	-	-	-	-	-	-	-	
Sound power [Standard]	dB(A)	89	90	90	90	92	91	92	91	93	93	93	93	94	95	
Sound power [Low noise]	dB(A)	86	87	87	87	89	87	88	87	89	89	90	89	90	91	
Sound power [Super Low noise]	dB(A)	85	85	85	87	85	86	85	87	87	88	87	88	89	89	
Dimensions [LxHxD]	mm	3520x2652x2256			4520x2652x2256			5520x2652x2256			6520x2652x2256			9085x2652x2256		11085x2652x2256







20% Ethylene glycol | Also available with 60 Hz power supply | Data declared with use of R410A refrigerant

# TAL

## CLASS A CHILLERS AND HEAT PUMPS AIR CONDENSED WITH SCROLL COMPRESSORS

283-1166 kW



 MULTI-PROTOCOL COMMUNICATION INTERFACE	 SCROLL COMPRESSORS	 AXIAL FANS
 CORROSION RESISTANT MATERIAL	 A2L READY	 LOW GWP REFRIGERANT
 PLATE HEAT EXCHANGER		 CLASS A

The TAL range chillers and heat pumps are air/water units in energy class A for both cooling and heating, available for use with R410A refrigerant or, in the "A2L" version, with low environmental impact R454B refrigerant. The TAL range is designed to manage the **conditioning of industrial plants and thermal loads in technological applications, where 24/7 reliability in all working conditions, one of the assets of these units, is a critically important requirement.** The TAL range uses latest generation Scroll compressors, braze-welded plate exchangers optimised for use with high pressure refrigerants (R410A/R454B) and axial fans suitable for outdoor installation.

- 3 different soundproofing setups available: Standard, Low Noise and Super Low Noise
- High power density units in both chiller and heat pump modes
- Optional EC fans
- Electronic expansion valve
- Easy accessibility thanks to the optimisation of the internal space





**Easy maintenance**

To carry out maintenance of the condensing coil manifolds and refrigeration circuit components, which are located behind the electrical panel, the TAL range is supplied as standard with the Hi-Rail sliding guide. This allows **the control panel to be easily removed**, resulting in extra space for unscheduled maintenance, **without impacting the footprint required for normal operation of the unit.**



**Plate heat exchangers**

The TAL range uses braze-welded plate exchangers with asymmetrical channels, suitable for the use of high and medium pressure refrigerant gases. The configuration with asymmetrical channels **allows high exchange efficiencies to be reached while maintaining pressure drops low** on the water side, **therefore reducing pumping costs** at both full and partial load.

**Maximised energy efficiency**

The units of the TAL range fall within the **energy efficiency class A**, in both the chilling only version and the heat pump version. This is thanks to a careful selection of internal components, which also includes the adoption of **innovative high efficiency Scroll compressors with direct start, permanent magnet motor technology.** The high modulation range guaranteed by the multi-Scroll technology allows cooling/heating requirements to be met at any time, **minimising energy waste and increasing seasonal efficiency.**

TAL		294FS	324FS	374FS	404FS	454FS	496FS	556FS	596FS	636FS	676FS	748FS	808FS	868FS	900FS	1072FS
<b>User water temperature 12/7°C 20% ethylene glycol, outside air 35°C, 40% R.H.</b>																
Cooling capacity	kW	283.2	316.9	366.2	392.9	433.7	476.3	532.1	580.3	621.3	642.9	738.9	781.8	831.4	900.4	1064.6
Total absorbed power	kW	87.3	102.9	115.1	126	147.4	152.7	176.6	193.6	201.1	216.6	229.7	251.8	264.5	293.2	352.7
EER		3.24	3.08	3.18	3.12	2.94	3.12	3.01	3	3.09	2.97	3.22	3.11	3.14	3.07	3.02

TAL		294CS	324CS	374CS	404CS	454CS	496CS	556CS	596CS	636CS	676CS	748CS	808CS	868CS	900CS	1072CS	
<b>Utility water temperature 12/7°C, ethylene glycol 20%</b>																	
Full free-cooling temperature	°C	-8.9	-8.4	-4.6	-5.4	-7	-4.4	-6.1	-7.6	-5.3	-5.8	-5.3	-6.2	-4.6	-6.1	-6.1	
Sound power [Standard]	dB(A)	89	90	90	90	92	91	92	91	93	93	93	93	94	94	95	
Sound power [Low noise]	dB(A)	86	87	87	87	89	87	89	88	90	90	90	90	91	91	92	
Sound power [Super Low noise]	dB(A)	83	85	85	85	86	85	87	86	87	88	88	87	88	89	90	
Dimensions [LxHxD]	mm	3865x2652x2256			4865x2652x2256			5860x2652x2256			6860x2652x2256		7865x2652x2256		8865x2652x2256		11270 x2652 x2256

TAL		294CS	324CS	374CS	404CS	454CS	496CS	556CS	596CS	636CS	676CS	748CS	808CS	868CS	900CS	1072CS	
<b>Cooling: User water values 12/7°C, 35°C outside air, 40% U.R.</b>																	
Cooling capacity	kW	286.1	319.8	370.1	397.8	450	482.7	539.7	588.7	629.9	662.1	746.6	791.3	841.2	911.8	1079.7	
Total absorbed power	kW	86.2	101.9	114	124.4	145.3	150.3	173.7	190.5	198	213.2	226.8	248.1	261.1	289.2	347.2	
EER		3.32	3.14	3.25	3.2	3.1	3.21	3.11	3.09	3.18	3.1	3.29	3.19	3.22	3.15	3.11	
SEER		5.18	4.96	5.08	5.05	4.96	5.25	5.22	5.32	5.3	5.18	5.08	5.01	4.97	4.98	5.12	
SEPR		5.67	5.65	5.61	5.62	5.6	5.68	5.69	5.78	5.7	5.61	5.75	5.7	5.62	5.76	5.72	
Sound power [Standard]	dB(A)	89	90	90	90	92	91	92	91	93	93	93	93	94	94	95	
Sound power [Low noise]	dB(A)	86	87	87	87	89	87	89	88	90	90	90	90	91	91	92	
Sound power [Super Low noise]	dB(A)	83	85	85	85	86	85	87	86	87	88	88	87	88	89	90	
Dimensions [LxHxD]	mm	3520x2652x2256			4520x2652x2256			5520x2652x2256			6520x2652x2256		7520x2652x2256		8520x2652x2256		11085 x2652 x2256

TAL		294HS	324HS	374HS	404HS	454HS	496HS	556HS	596HS	636HS	676HS	748HS	808HS	868HS	900HS	1072HS
<b>Heating: User water values 40/45°C, 7°C outside air, 89% U.R.</b>																
Thermal power	kW	292.2	334.3	395.6	421.7	474.9	513.9	573.4	625.2	674.4	706.6	789.6	829.5	884.4	960.3	1165.9
Total absorbed power	kW	90.6	104.1	119.6	128.2	146.5	159.8	178.5	194.5	209.5	219.5	236.4	256.3	274.5	298.2	362.4
SEER		-	-	-	-	-	-	-	5.31	5.19	5.25	4.99	4.94	4.84	4.98	5.16
COP		3.22	3.21	3.31	3.29	3.24	3.22	3.21	3.21	3.22	3.22	3.26	3.24	3.22	3.22	3.22
SCOP		4.16	4.27	4.12	4.13	4.21	3.98	4.11	-	-	-	-	-	-	-	-
Sound power [Standard]	dB(A)	89	90	90	90	92	91	92	91	93	93	93	93	94	95	96
Sound power [Low noise]	dB(A)	86	87	87	87	89	87	88	87	89	89	90	89	90	91	92
Sound power [Super Low noise]	dB(A)	85	85	85	87	85	86	85	87	87	88	87	88	89	89	90
Dimensions [LxHxD]	mm	3520x2652x2256			4520x2652x2256			5520x2652x2256			6520x2652x2256		9085x2652x2256		11085 x2652 x2256	12930 x2652 x2256

20% Ethylene glycol | Also available with 60 Hz power supply | Data declared with use of R410A refrigerant

# TPL

## AIR CONDENSED CHILLERS AND HEAT PUMPS WITH SCROLL COMPRESSORS

365-1199 kW



 MULTI-PROTOCOL COMMUNICATION INTERFACE	 SCROLL COMPRESSORS	 AXIAL FANS	 CORROSION RESISTANT MATERIAL
 A2L READY	 LOW GWP REFRIGERANT	 PLATE HEAT EXCHANGER	

The TPL range chillers and heat pumps are high power density air/water units available for use with R410A refrigerant or, in the "A2L" version, with low environmental impact R454B refrigerant. The TPL range is designed to manage **the conditioning of industrial plants and thermal loads in technological applications, where 24/7 reliability in all working conditions, one of the assets of these units, is a critically important requirement.** The TPL range uses latest generation Scroll compressors, braze-welded plate exchangers optimised for use with high pressure refrigerants (R410A/R454B) and axial fans suitable for outdoor installation.

- 3 different soundproofing setups available: Standard, Low Noise and Super Low Noise
- High power density units in both chiller and heat pump modes
- Optional EC fans
- Electronic expansion valve
- Easy accessibility thanks to the optimisation of the internal space





### Plate heat exchangers

The TPL range uses braze-welded plate exchangers with asymmetrical channels, suitable for the use of high and medium pressure refrigerant gases. The configuration with asymmetrical channels allows **high exchange efficiencies to be reached while maintaining pressure drops low** on the water side - **reducing pumping costs** at both full and partial load.

### Maximum efficiency at partial loads

The adoption of the multi-Scroll solution, the use of electronically controlled expansion valves, selection of plate heat exchangers, fan modulation and variable flow rate controlled with circulation pumps are all key features that make the **TPL range particularly efficient at partial loads**.



TPL	374F	414F	456F	486F	536F	616F	658F	748F	818F	900F	942F	1072F	
<b>User water temperature 12/7°C 20% ethylene glycol, outside air 35°C, 40% R.H.</b>													
Cooling capacity	kW	365.3	421	451.4	507.5	556.6	613.7	683.1	752.4	824.9	940.1	1042.4	1097.7
Total absorbed power	kW	132.7	146.5	163.1	190.6	193.4	224.7	253.7	264.7	309.1	327.1	371.3	404.3
COP		2.75	2.87	2.77	2.66	2.88	2.73	2.69	2.84	2.67	2.87	2.81	2.72

TPL	374C	414C	456C	486C	536C	616C	658C	748C	818C	900C	942C	1072C	
<b>Utility water temperature 12/7°C, ethylene glycol 20%</b>													
Full free-cooling temperature	°C	-10.3	-6.6	-7.8	-9.8	-6.8	-8.3	-10.3	-8.5	-10.1	-9.4	-11.3	-9.4
Sound power [Standard]	dB(A)	90	92	91	92	91	93	93	93	95	93	95	94
Sound power [Low noise]	dB(A)	87	89	89	90	89	91	91	90	92	91	93	92
Sound power [Super Low noise]	dB(A)	86	87	87	88	88	89	89	89	90	89	90	90
Dimensions [LxHxD]	mm	3415 x2652 x2256	4415x2652x2256			5415 x2652 x2256	5415x2650x2256		6415x2650x2256		7415x2650x2256		8415 x2650 x2256

TPL	374C	414C	456C	486C	536C	616C	658C	748C	818C	900C	942C	1072C	
<b>Cooling: User water values 12/7°C, 35°C outside air, 40% U.R.</b>													
Cooling capacity	kW	369.7	426	457.6	515.3	565.2	622	694.9	764.2	837.9	957.7	1062	1112.9
Total absorbed power	kW	131.2	144.9	161.1	187.9	190.2	221.1	249.8	261	305	320.9	364.8	398.5
EER		2.82	2.94	2.84	2.74	2.97	2.81	2.78	2.93	2.75	2.98	2.91	2.79
SEER		4.81	4.87	4.95	4.96	5.14	5.02	4.71	4.85	4.71	4.96	5.09	5.05
SEPR		5.66	5.69	5.75	5.67	5.87	5.7	5.71	5.9	5.73	6.01	5.95	6
Sound power [Standard]	dB(A)	90	92	91	92	91	93	93	93	95	93	95	94
Sound power [Low noise]	dB(A)	87	89	89	90	89	91	91	90	92	91	93	92
Sound power [Super Low noise]	dB(A)	86	87	87	88	88	89	89	89	90	89	90	90
Dimensions [LxHxD]	mm	3065 x2652 x2256	4065x2652x2256			5065 x2652 x2256	5065 x2650 x2256	5060 x2650 x2256	6060x2650x2256		7060x2650x2256		8060 x2650 x2256

TPL	374H	414H	456H	486H	536H	616H	658H	748H	818H	900H	942H	1072H	
<b>Heating: User water values 40/45°C, 7°C outside air, 89% U.R.</b>													
Thermal power	kW	391.8	476.4	511.6	578.4	601	679.4	734.6	769.2	855.8	997.6	1114.5	1199.3
Total absorbed power	kW	130.8	150.6	161.7	181.8	199.6	226.1	236	254.3	286.2	322.5	358.4	394.1
SEER		-	-	-	-	5.14	5.02	4.71	4.81	4.67	4.71	4.85	5.13
COP		3	3.16	3.16	3.18	3.01	3	3.11	3.02	2.99	3.09	3.11	3.04
SCOP		4.03	4.06	3.98	4.05	-	-	-	-	-	-	-	-
Sound power [Standard]	dB(A)	90	92	91	92	91	93	93	93	95	94	95	94
Sound power [Low noise]	dB(A)	87	89	89	90	89	91	91	90	92	91	93	92
Sound power [Super Low noise]	dB(A)	86	87	87	88	88	89	89	89	90	90	91	91
Dimensions [LxHxD]	mm	3065 x2652 x2256	4065x2652x2256			5065 x2652 x2256	5065 x2650 x2256	5060 x2650 x2256	6635x2650x2256		8635x2650x2256		10635 x2650 x2256

20% Ethylene glycol | Also available with 60 Hz power supply | Data declared with use of R410A refrigerant



# HIGH TEMPERATURE HEAT PUMPS

# KVW

## HIGH TEMPERATURE HEAT PUMPS WITH TWO-STAGE COMPRESSORS

324-2208 kW



 MULTI-PROTOCOL COMMUNICATION INTERFACE	 SCREW COMPRESSORS	 CORROSION RESISTANT MATERIAL
 CLASS A	 LOW GWP REFRIGERANT	 SPRAY FLOODED SHELL AND TUBE

KVW is HiRef's range of water-condensed high-temperature heat pumps with **two-stage screw compressors, spray flooded shell and tube evaporator and shell and tube condenser**. The units are available with traditional refrigerant R515B or R1234ze, with a **very low GWP** (Global Warming Potential) value. The range covers the thermal power range from 400 to 2000kW\* and reaches COP values of 2.2 producing water at +90°C (with R1234ze) from a source at -2°C. The **KVW extra high temperature heat pump series is ideally suitable for low-medium temperature heat recovery to produce hot water for district heating networks or industrial processes.**

- Available refrigerants: R1234ze and R515B
- Available in version: heating only heat pumps for high temperatures and chiller with total high temperature recovery.
- Monitoring and limitation of the maximum absorbed power
- Standard supply with inverter-driven screw compressors (included), in enclosed version, allowing power modulation from 25% to 100%.
- Thermal insulating hoods on compressors for high-temperature heat pump versions (optional)
- Modulation and supervision managed by the software
- Available in a single-circuit version with a single compressor and a dual-circuit version with two compressors

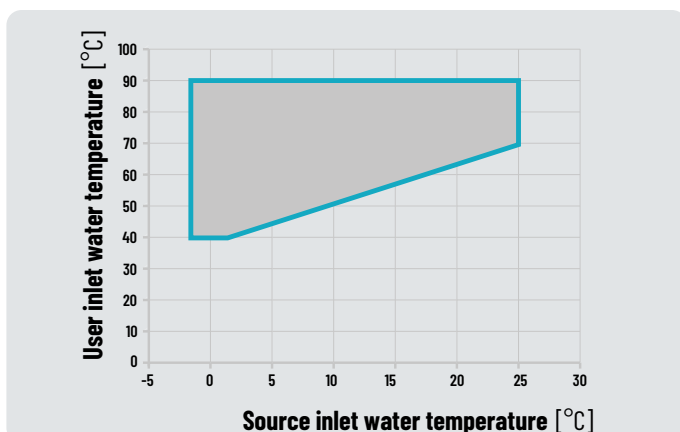



**Power and flexibility**

Screw compressor allows achievement of **high cooling capacities** with load modulation via the special slide valve, **with obvious advantages in terms of energy efficiency.**



**Two-level evaporation**

The unit is equipped with a flooded evaporator with spray technology and double water-side passage. With this technology, **the refrigerant charge is reduced by 30% compared to a standard flooded bundle.**



**Standard touch screen display**

The KVV series comes with a **touch screen display and customized software and screens as standard.** On request, total web monitoring can be integrated through an Ethernet card

**Production of hot water up to 90°C**

The units of the KVV range **can produce water at a temperature of 90°C even from a very cold source.** Thanks to this feature, the heat pumps can be integrated into the **district heating circuits** even in replacement of traditional heat generators.

**Economiser, power and flexibility**

The integration of the refrigeration circuit with the economiser allows **the heat output of the heat pump and also the efficiency (COP) to be increased.**

**Optimised installation space**

The unit is available in both standard and 'mirrored' layout versions. When ordered together, the two versions **can be placed adjacent to each other on the long side** in order to occupy **as little space as possible in the heating plant and facilitate maintenance operations.**

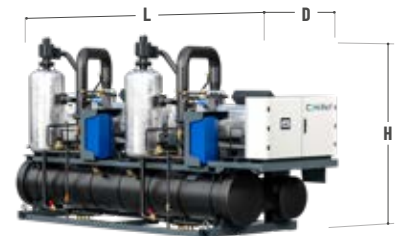

KVV		300K	500K	1001K	2001K
<b>User water temperature 65/85°C, Source water temperature 4/1°C 20% ethylene glycol</b>					
<b>Thermal power</b>	kW	324	535	1104	2208
<b>Total absorbed power</b>	kW	135.2	227.6	460	920
<b>Sound power [Standard]</b>	dB(A)	95	96	99	102
<b>Dimensions [LxHxD]</b>	mm	3233X2651X1800	3815X2651X1800	5180X2574X1800	5180X2574X3600

The 2000kW unit is composed of two 1000kW modules built in a symmetrical configuration

# XVA K

## HEATING-ONLY WATER CONDENSED HEAT PUMPS WITH INVERTER DRIVEN SCREW COMPRESSORS

408-1679 kW



 MULTI-PROTOCOL COMMUNICATION INTERFACE	 SCREW COMPRESSORS	 SHELL AND TUBE HEAT EXCHANGER	 FAST RESTART
 CORROSION RESISTANT MATERIAL	 CLASS A	 LOW GWP REFRIGERANT	

XVA K is HiRef's range of water-cooled chillers with screw compressors and shell and tube heat exchangers. Use of the new R1234ze refrigerant, **with ultra-low GWP** (Global Warming Potential), and **achievement of high energy efficiency levels**, especially at partial loads, **ensures the system has a low TEWI** (Total Equivalent Warming Impact). Using the R1234ze refrigerant, water temperatures of up to 90°C can be achieved; upon request, the R1233zd refrigerant can be selected, allowing temperatures to reach up to 120°C. The broad capacity range offered and the availability of different versions caters to a wide variety of needs.

- Available refrigerants: R1234ze and R515B
- Available versions: heating only heat pump and heating only heat pump for high temperatures
- Electronic expansion valve
- Monitoring and limitation of the maximum absorbed power
- Available with screw compressors driven by inverter as standard
- Thermal insulating jackets on compressors

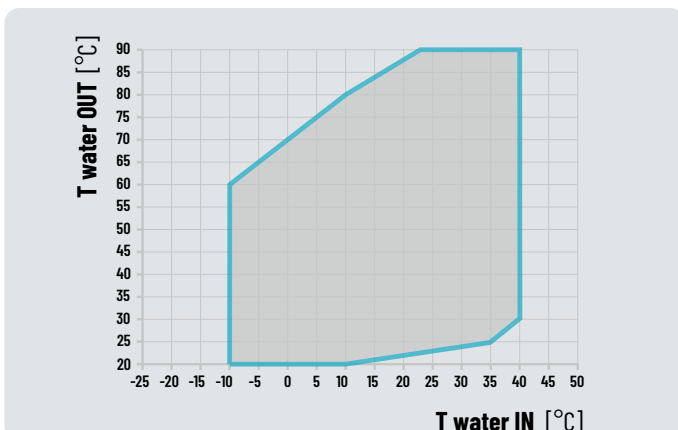

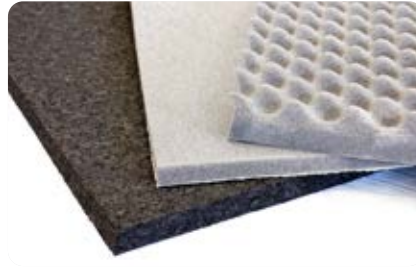

**Power and flexibility**

Screw compressor allows **high thermal power** to be achieved with load modulation via the special slide valve. A version with inverter either on one or on both compressors is available, **for finer adjustment of cooling capacity and obvious advantages in terms of energy efficiency.**

**Low Noise set-up**

The screw compressors, the only source of noise on the machine, can be placed in a dedicated enclosure lined with sound-absorbing material **that reduces the overall noise emission.**

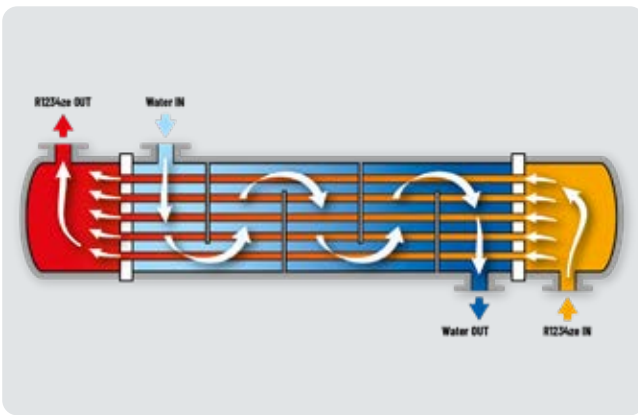

**New concept of heat exchange**

Single pass shell and tube evaporators provide **excellent levels of thermodynamic efficiency** thanks to full heat exchange counter-flow.



XVA K	039YK	043IK	044YK	049IK	051YK	057IK	060YK	060IK	066YK	066IK	075YK	075IK	086YK	086IK	106YK	117IK	126YK	138IK	147YK	147IK	172YK	172IK	
<b>Heating: User water temperature 80/90°C, Source water temperature 45/40°C</b>																							
<b>Thermal power</b>	kW	408.2	425.5	456	475.1	528.8	551.3	592.7	592.7	649.9	649.9	735.4	735.4	848	848	1080	1125.6	1284.4	1339.2	1442.5	1442.5	1679	1679
<b>Total absorbed power</b>	kW	135.9	142.8	151.0	160.5	176.3	186.9	191.8	193.7	217.4	219.6	248.1	250.6	284.1	286.5	349.5	370.3	401.4	425.1	442.5	446.6	496.7	501.2
<b>COP</b>		3.04	5.10	3.02	2.96	3.00	2.95	3.09	3.06	2.99	2.96	2.96	2.93	2.98	2.96	3.09	3.04	3.20	3.15	3.26	3.23	3.38	3.35
<b>SCOP</b>		4.94	5.10	5.04	5.12	4.99	5.15	5.10	5.21	5.11	5.22	5.09	5.20	5.17	5.26	5.06	5.21	5.16	5.31	5.22	5.36	5.35	5.47
<b>Sound power [Standard]</b>	dB(A)	91	92	91	92	91	92	91	91	95	95	95	95	96	96	96	97	97	98	97	97	98	98
<b>Dimensions [LxHxD]</b>	mm	3937x1507x2000				4700x1507x2000				4700x1650x2200				5198x1817x2450				5288 x1817 x2450					



# HYDRAULIC MODULES

# PLM

## POLYMORPH HYDRONIC MODULES FOR WATER/WATER CHILLERS SYSTEMS



HiRef Polymorph modules provide a **solution that “converts” a water-condensed chiller into a more advanced system**. The water management system is the “master” element of the heating system. Thanks to **a hydronic circuit specially designed for the application, and built-in software to control the different operating modes**, any water-to-water chiller (even of a different brand) can also be used as: a reversible heat pump, a chiller with total recovery, a multipurpose heat pump for 2-pipe systems, a multipurpose heat pump for 4-pipe systems or an air conditioning system with Free-Cooling.

- The PLM module, unlike traditional pumping modules, acts as the “master” unit managing the system, which can be made up of one or more chillers in parallel
- Built-in software for managing the different modes and interfacing with the chiller
- Compatibility with any chiller, even if already present in the system
- Vic-Taulic type quick water couplings
- Suitable for any chiller size
- Also available in Low-Noise silenced set-up with internal compartment lined with sound-absorbing material
- Standard high efficiency pumps



**PLM - H**  
POLYMORPH

**Reversible heat pump**

The Polymorph PLM-H module allows a **reversible heat pump to be obtained** for the production of chilled water or hot water when connected to a chilling-only water-water chiller.

**PLM - R**  
POLYMORPH

**Chiller with total recovery**

The Polymorph PLM-R module, in combination with a water-water chiller, **recovers 100% of the condensation heat** avoiding dissipation to the outside heat source and making heat available for different purposes.

**PLM - M**  
POLYMORPH

**2T multi-purpose heat pump**

The Polymorph PLM-M module is able to turn a water-condensed chilling-only chiller into a **multipurpose heat pump (with total condensation heat recovery)** suitable for installation in a "two-pipe" system. Its possible functions are:

- production of chilled water only;
- hot water production only set-point #1 (e.g. heating);
- hot water production only set-point #2 (e.g. DHW);
- production of chilled water and hot water at the same time set-point #2.

**PLM - P**  
POLYMORPH

**4T multi-purpose heat pump**

The Polymorph PLM-P module is suitable for **all so-called "four-pipe" systems** where hot and cold water must be produced at the same time. The water/water chiller combined with the PLM-P allows the following functions:

- production of chilled water only;
- production of hot water only;
- production of chilled water and hot water at the same time.

**PLM - F**  
POLYMORPH

**Free-Cooling system**

A Dry Cooler water-condensed water chiller can be combined with a Polymorph PLM-F module to convert the system **into a Free-Cooling system**. Outdoor air, if sufficiently cold, is used as a source of cooling capacity **allowing considerable savings of electricity**. Below the TFT (Total Free-Cooling Temperature) the compressors are switched off and the cooling demand is completely **covered with the only consumption being from auxiliaries** (fans and circulators).

PLM	FRAME 1	FRAME 2	FRAME 3	FRAME 4	
<b>FRAME 1</b>					
<b>Dimensions [LxHxD]</b>	mm	1174x1590x772	1644x1590x772	2374x1850x877	3130x1850x877

Also available with 60 Hz power supply





# SUPERVISION

INDUSTRIALE

# HiNode

ADVANCED TECHNOLOGY  
AND FLEXIBILITY TO MANAGE  
AIR CONDITIONING AND PROCESS COOLING



**HiNode 2.0** is a complete system for the management and supervision of air conditioning and process cooling plants, capable of interfacing with all units and devices in an installation to make operation more efficient.

Advanced and flexible in use, **HiNode 2.0** can monitor system performance and optimally manage fault resolution, ensuring maximum service continuity for the user. The system sizing is modular and can be defined each time according to the number of devices to be controlled.



## The heart of the device

Equipped with digital and analogue inputs and outputs to control the devices present (pumps, valves, etc.) and to acquire and record temperature, pressure, etc. values.

At the heart of **HiNode 2.0** is a programmable microprocessor **compatible with all major serial and Ethernet communication protocols**. Operating data can be accessed locally, via the LCD display or touch screen, or remotely, via the clear and intuitive web interface. The system can also be configured to send data to a third-party cloud service via MQTT protocol.



## Communication protocols

**HiNode 2.0** supports the following communication protocols: Modbus RTU or TCP/IP, BACnet MS-TP or IP, SNMP v1-v2c-v3, MQTT, and Redfish.

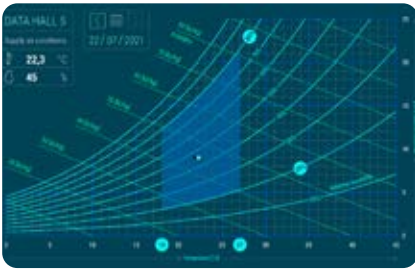

**Information management**

The system lets you verify the main operating variables for the managed units, displaying trends over time in graph form and recording them together with the event history. The data can also be exported in different formats and sent automatically by e-mail.



**User flexibility**

The software allows you to perform numerous basic functions and can be integrated with customised management logics, adapting itself to each type of plant. With HiNode 2.0 it is possible to achieve high energy efficiency and greater savings in operating costs. HiNode 2.0 software was designed and developed by the HiRef Controls team. It allows several basic operations to be performed and can be integrated with many customised functions according to the type of system to be managed.



**Operation logic**

The HiNode 2.0 software is designed and developed by HiRef and enables efficient management of the distribution of heat loads between installed units, even if they are of different ranges.

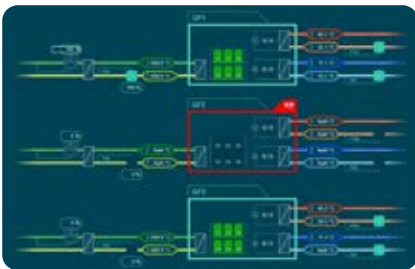

**On/off and modulating valve management**

Management of mixed climate zones. Control of groundwater rejection temperature.



**Controlled devices and functions: on/off and modulating distribution pump management**

Time rotation, constant or variable flow control, control with  $\Delta T$  or constant pressure. Flow balancing between primary and secondary circuits.



**Energy metering**

Measurement of thermal energy and electrical energy. With the possibility of using MID-certified devices (Measuring Instruments Directive 2014/32/EU).

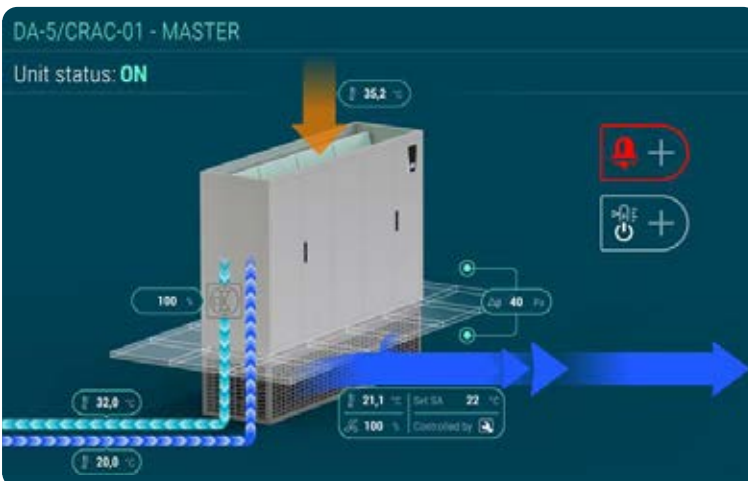

**Controlled devices and functions: HiRef air conditioning unit**

Management of load distribution between available units with selection of the most suitable resource, in addition to basic functions managed by LAN connected machines. Heating/cooling generation calculation based on working temperatures between primary and secondary circuits. Running time balancing and advanced Dynamic Setpoint function.

**Fast, integrated and complete solutions:** DataDom meets this demand by reducing implementation time through a turnkey approach that integrates cooling, electrical systems, UPS, generators, and all components not directly supplied by HiRef.

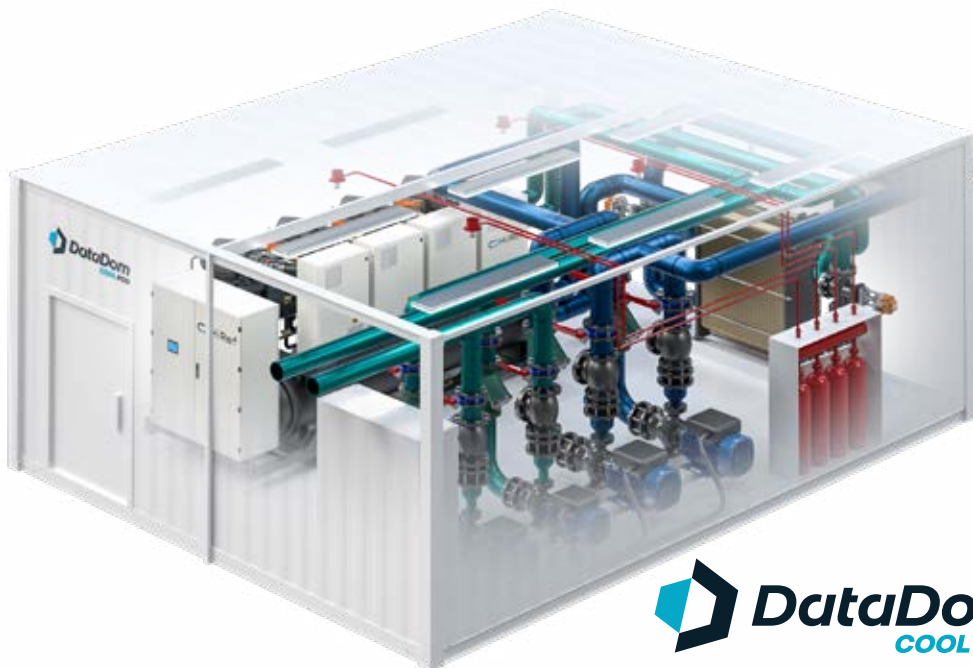
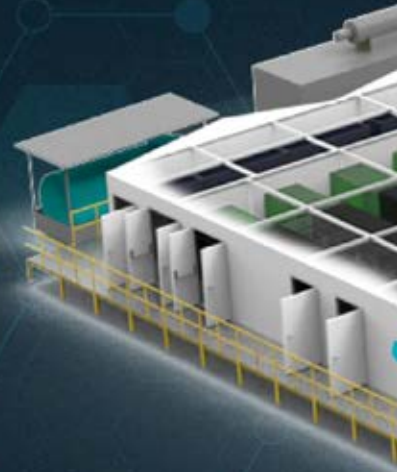

 **DataDom**  
COOL POD



 **DataDom**  
DATA BOX

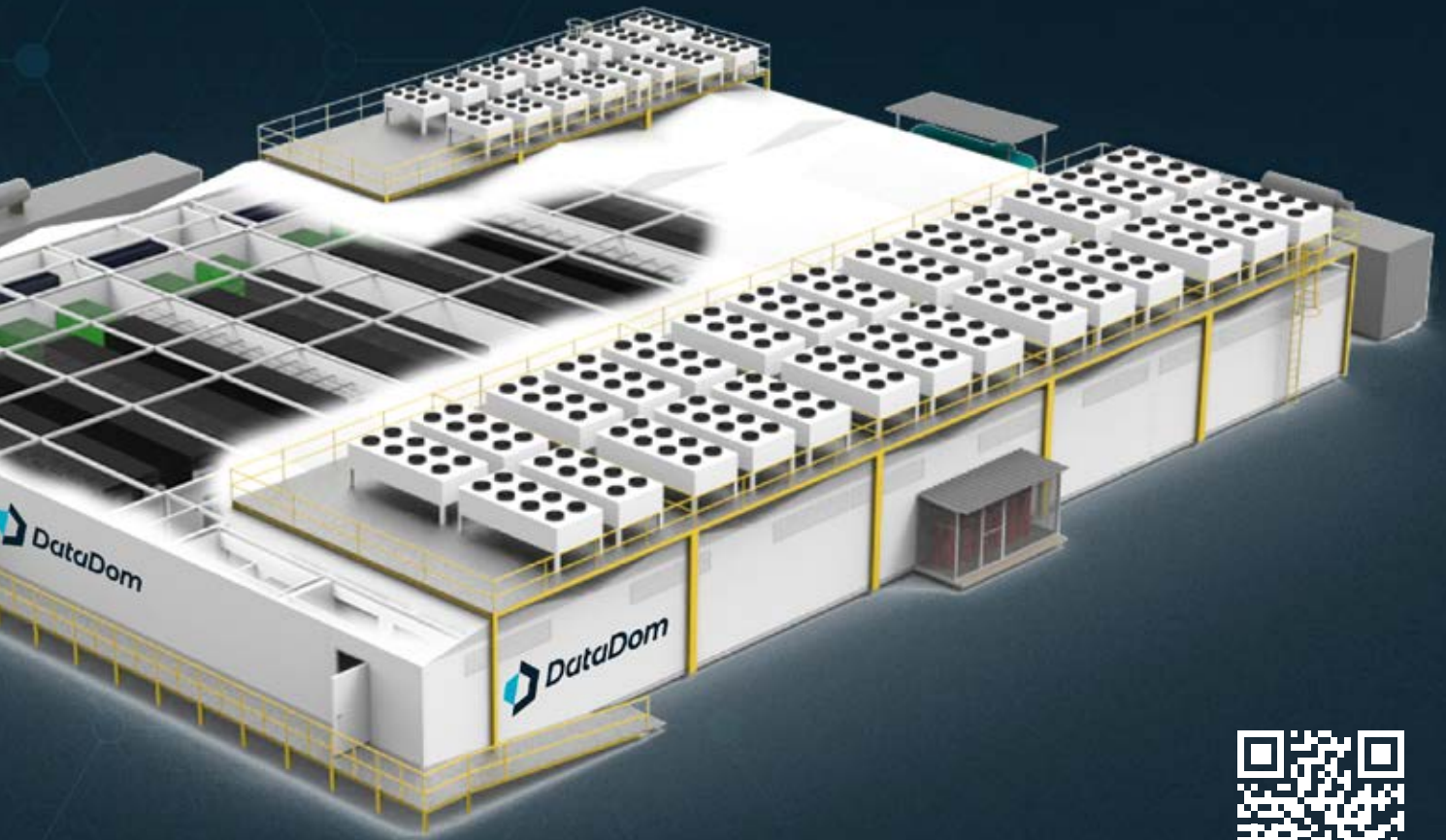

- 1 Air and liquid conditioning
- 2 CFD analysis
- 3 Racks and containment
- 4 UPS and PDU
- 5 Lighting
- 6 Access control system
- 7 Fire prevention
- 8 Supervision and control system
- 9 Generator
- 10 Electricity distribution
- 11 Commissioning of the plant

 HiRef

The background features a complex, abstract pattern of glowing, fiber-optic-like lines that swirl and radiate outwards from a central dark circular void. The lines are composed of numerous fine, overlapping strands, creating a sense of depth and movement. The overall color palette is a range of blues, from deep navy to bright cyan, with the glowing lines appearing as light blue and white. The text is overlaid on this background, with the main title in white and the subtitle in a light blue color that matches the background's glow.

# INNOVATORS

above the standards

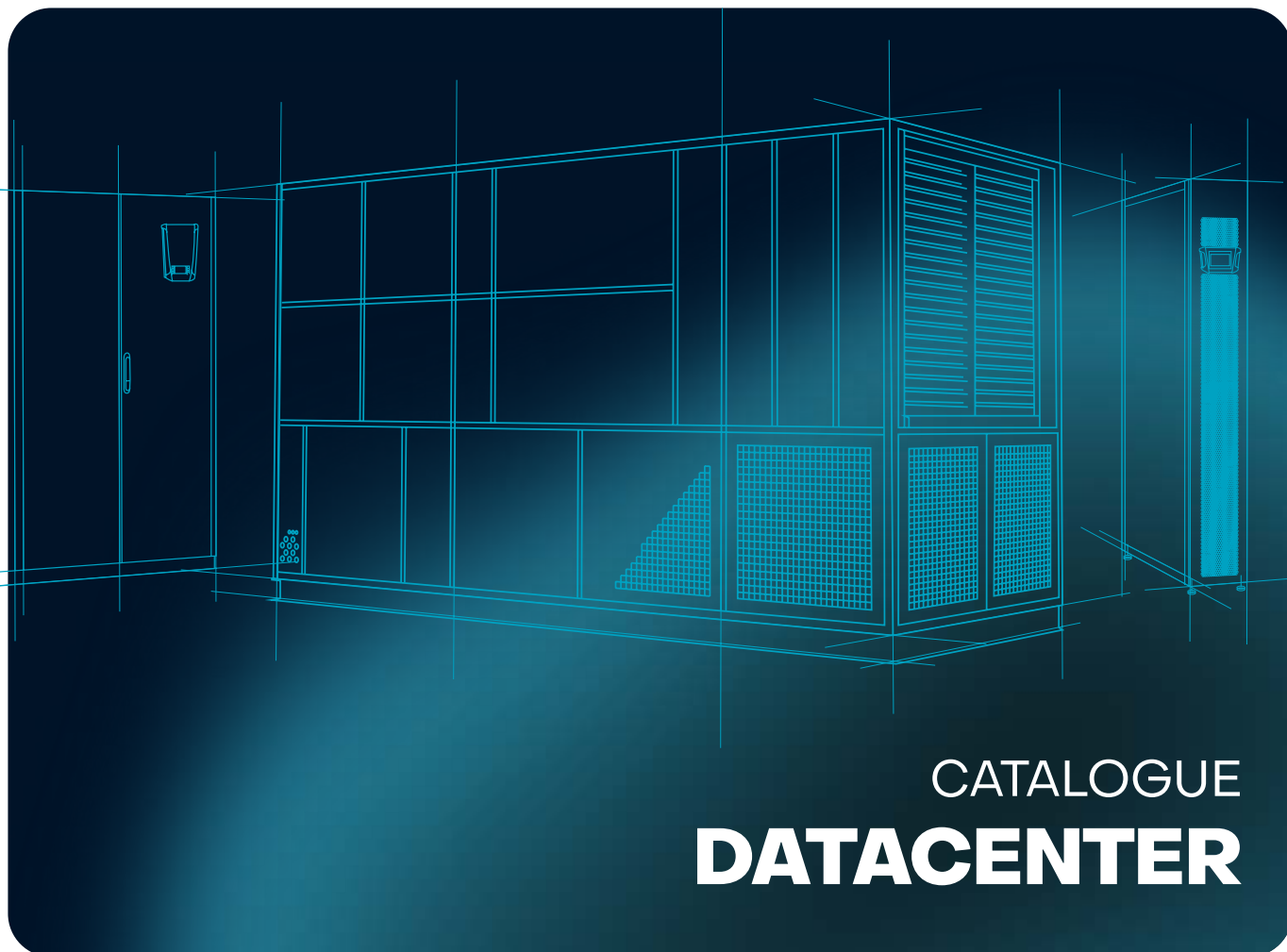

# CATALOGUE DATACENTER



**HiRef S.p.A.** Viale Spagna, 31/33 - 35020 Tribano (PD) Italy

Tel. +39 049 9588511 - [info@hiref.it](mailto:info@hiref.it)

**HiRef S.p.A.** reserves the right, at any time, to introduce any necessary changes and improvements to its products without prior notice.  
Reproduction, even partial, of this catalogue is forbidden without a written permission from HiRef S.p.A.

© Copyright HiRef S.p.A. 2026